

CITY OF EVANSTON

SPECIFICATIONS AND BID DOCUMENTS
Construction Bid with Sub-contractors

BID NUMBER: 22-27

For

2022 CDBG Improvements and Gap Infill
March 31, 2022



BID DUE DATE: 2:00 P.M., Tuesday, May 3, 2022

VIRTUAL BID OPENING: 2:15 P.M., Tuesday, May 3, 2022
Google Meet ID:
meet.google.com/erk-vjyw-pza
Phone Numbers:
(US) [+1 617-675-4444](tel:+16176754444)
PIN: 491 020 418 0044#

BID BOND: 5% of Contract Amount

**PERFORMANCE/MATERIAL
& LABOR PAYMENT BOND:** 100% of Contract Amount

CONTRACT PERIOD: Contract award through August 31, 2022

ELECTRONIC BID SUBMITTAL:

Bid responses will only be accepted electronically
via E-bidding through DemandStar (WWW.DEMANDSTAR.COM)

**It is highly recommended that new DemandStar users complete the account
setup process prior to project due date/time.**

TABLE OF CONTENTS

SPECIFICATION SECTION NUMBERS	PAGES
DIVISION 0 – BIDDING REQUIREMENTS	
Notice to Bidders.....	1
Instructions to Bidders/Requirements for Bidding	12
M/W/EBE Specifications	Page 10
Questions.....	Page 11
General Conditions	12
Insurance Requirements	1
DOCUMENTS TO BE RETURNED WITH THE BID	
Exhibit A Bid Form	13
Exhibit B City of Evanston M/W/EBE Policy	1
Exhibit C M/W/EBE Participation Compliance Form.....	1
Exhibit D M/W/EBE Participation Waiver Request	1
Exhibit E Construction Contractors’ Assistance Organizations	1
*Exhibit F Local Employment Program Compliance.....	2 – Not Used
Exhibit G Certification of Bidder Regarding Equal Employment Opportunity	1
Exhibit H Disclosure of Ownership Interests	4
Exhibit I Additional Information Sheet.....	1
Exhibit J Certification of Compliance with Prevailing Wage Rate Act	1- Not Used
Exhibit K Major Subcontractors Listing	1
Exhibit L Conflict of Interest	1
Exhibit M Signature Form.....	1
Exhibit N Contractor Services Agreement Acknowledgement ...	1
Exhibit N Contractor Services Agreement	23
Exhibit O BID/Proposal Submittal Label	1
Exhibit P Compliance with Federal Standards	1
Exhibit Q Section 3 Compliance Plan.....	1
Exhibits F and J have been intentionally left out of this document	
ATTACHMENTS	
Contract Specification	90
2022 CDBG Sidewalk Improvements and Gap Infill Plan Set.....	5
DemandStar E-bidding Information.....	14

***NOTE: THE SELECTED BIDDER WILL BE SUBJECT TO THE REGULATIONS CONTAINED IN CITY OF EVANSTON ORDINANCE 60-O-14 AMENDMENTS TO THE LOCAL EMPLOYMENT PROGRAM (LEP)**

**CITY OF EVANSTON
NOTICE TO BIDDERS**

Bids will be received by the City's Purchasing Office until 2:00 P.M. local time Tuesday, May 3, 2022 and will be publically read virtually via Google Meets at 2:15 P.M. Interested parties can use the following link: meet.google.com/erk-vjyw-pza or join by phone 617-675-4444 PIN: 491 020 418 0044# to access the virtual bid opening. Effective immediately, the City of Evanston will no longer accept hard copy paper submittals for any solicitation. Responses will only be accepted electronically via E-bidding through DemandStar (www.demandstar.com). Although registration is required, vendors can download solicitations and upload responses for free. Bids shall cover the following:

**2022 CDBG Sidewalk Improvements and Gap Infill
Bid Number: 22-27**

Work on this project includes all materials, equipment and services for replacement and/or installation of sidewalk at various locations in the City of Evanston. Bidders must be prequalified by the Illinois Department of Transportation (IDOT) and present an IDOT issued "Certificate of Eligibility" with the bid proposal.:

The above item shall conform to the Invitation for Bids on file in the Purchasing Office. Parties interested in submitting a bid should contact the Purchasing Office to receive a copy of the bid or see the City's website at: www.cityofevanston.org/business/bids-proposals/ or DemandStar at: www.demandstar.com.

This project is being funded by the City's Community Development Block Grant Program, a Federal entitlement grant authorized under Title I of the Housing and Community Development Act of 1974 and is therefore, subject to compliance with federal regulations issued pursuant to said Act. Furthermore all interested bidders are notified that successful contractors and subcontractors must comply with Federal Labor Standards issued under Section 570.603 of the Code of Federal Regulations, which include (1) the Davis-Bacon Minimum Wage Act, as amended, (40 U.S.C. 276a-276a-5) and the Contractor's Work Hours and Safety Standards Act (40 U.S.C. 327 et seq.), (2) the equal opportunity provisions of Executive Order 11246 as amended, and (3) all other federal laws and regulations issued pertaining to labor standards and as stated in the project specifications. All specified contractors and subcontractors must obtained a Unique Entity ID (SAM) in order to be compliant with federal reporting and must not be listed on the Excluded Parties List System in the System for Award Management (SAM) for debarment or suspension from doing business with the United States government.

Further this project is subject to the regulations stipulated by Section 3 of the Housing and Urban Development Act 1968, and CFR 24 §75.19. This calls for affirmative action by the Contractor to train and/or hire lower income residents of the project area and to Subcontract with local small businesses.

The City of Evanston (the City) in accordance with the laws of the State of Illinois, hereby notifies all Bidders that it will affirmatively ensure that the contract(s) entered into pursuant to this Notice will be awarded to the successful Bidders without discrimination on the ground of race, color, religion, sex, age, sexual orientation, marital status, disability, familial status or national origin. The State of Illinois requires under Public Works contracts that the general prevailing rate of wages in this locality be paid for each craft or type of worker hereunder. This requirement is in accordance with The Prevailing Wage Act (820 ILCS 130) as amended. The City of Evanston reserves the right to reject any or all submittals or to accept the submittal(s) deemed most advantageous to the City.

The Evanston City Council also reserves the right to award the contract to an Evanston firm if that firm's bid is within 5% of the low bid.

Each Bidder shall be required to submit with their bid a disclosure of ownership interest statement form in accordance with the provisions of City Code Section 1-18-1 *et seq.* Failure to submit such information will result in the disqualification of such bid.

Linda Thomas
Purchasing Specialist

INSTRUCTIONS TO BIDDERS/REQUIREMENTS FOR BIDDING

1. ON-LINE NOTIFICATION OF SOLICITATIONS

The City is utilizing Demandstar.com (www.demandstar.com) for on-line notification purposes only for sealed bids when it is anticipated that the amount of the resulting contract will be in excess of its formal bid limit of \$25,000, such as this requirement. Interested Bidders are required to submit a sealed bid to the City by the date/time indicated for this requirement on the forms provided by the City.

2. SUBMISSION OF BIDS

- A. The City of Evanston will no longer accept hard copy paper submittals for any solicitation. Responses will only be accepted electronically via E-bidding through DemandStar (WWW.DEMANDSTAR.COM). Although registration is required, vendors can download solicitations and upload bid responses for free. **Please refer to attached DemandStar E-bidding documents.**
- B. ANY BIDS RECEIVED AFTER THE TIME AND DATE SPECIFIED FOR THE RECEIPT OF BIDS WILL NOT BE ACCEPTED. It is the sole responsibility of the Bidder to insure that his or her bid is delivered by the stated bid opening time. THE CITY IS NOT RESPONSIBLE FOR MISDIRECTED PACKAGES.
- C. Bids will be opened on the date and time stated.
- D. Any Bidder may withdraw his or her bid by letter or with proper identification by personally securing his or her bid at any time prior to the stated bid opening time. No telephone request for withdrawal of bids will be honored.

3. PREPARATION OF BIDS

The Bidder must prepare the bid on the attached bid forms. Unless otherwise stated, all blank spaces on the bid form or pages must be filled in. Either a unit price, lump sum price, or a "no-bid", as the case may be, must be stated for each and every item and must be either typed in or written in ink.

4. SIGNING OF BIDS

- A. Bids which are signed for a partnership should be signed in the firm's name by all partners or in the firm's name by Attorney-in-Fact. If signed by Attorney-in-Fact, there should be attached to the bid a Power of Attorney evidencing authority to sign the bid, dated the same date as the bid and executed by all partners of the firm.
- B. Bids which are signed for a corporation should have the correct corporate name thereon and signature of an authorized officer of the corporation manually written below the corporate name following words "By: _____" title of office held by the person signing for corporation, which shall appear below signature of an officer.

- C. Bids which are signed by an individual doing business under a fictitious name should be signed in the name of the individual "doing business as. _____."
- D. The name of each person signing the bid shall be typed or printed below his or her signature.

5. CONSIDERATION OF BIDS

The Purchasing Specialist shall represent and act for the City in all matters pertaining to this bid and the contract in conjunction therewith.

6. WITHDRAWAL OF BIDS

Bidders may withdraw or cancel their bids at any time prior to the advertised bid opening time. After the bid opening time, no bid shall be withdrawn or canceled for a period of sixty (60) calendar days. When contract approval is required by another agency, such as the Federal Government or the State of Illinois, no bid shall be withdrawn or canceled for a period of ninety (90) calendar days.

7. ERRORS IN BIDS

Bidders are cautioned to verify their bids before submission. Negligence on the part of the respondent in preparing the bid confers no right for withdrawal or modification of the bid after it has been opened. In case of error in the extension of prices in the bid, unit prices will govern.

8. ADDENDA

- A. Any and all changes to the specifications/plans are valid only if they are included by written addendum to all Bidders. Each Bidder must acknowledge receipt of any addenda by indicating on the Bid form. Each Bidder, by acknowledging receipt of any addenda, is responsible for the contents of the addenda and any changes to the bid therein. Failure to acknowledge any addenda may cause the bid to be rejected.
- B. Addenda information is available over the internet at: [City of Evanston Notices to Bidders](#) or www.demandstar.com, or by contacting the Purchasing Office.

9. RESERVED RIGHTS

The City of Evanston reserves the right at any time and for any reason to cancel his or her solicitation, to accept or reject any or all bids or any portion thereof, or to accept an alternate response. The City reserves the right to waive any immaterial defect in any response. The City may seek clarification from any respondent at any time, and failure to respond within a reasonable time period, or as otherwise directed, will be cause for rejection.

10. AWARD

It is the intent of the City to award a contract to the lowest responsible Bidder meeting specifications. The City reserves the right to determine the lowest responsible Bidder on the basis of an individual item, groups of items, or in any

way determined to be in the best interest of the City. Award will be based on the following factors (where applicable): (a) adherence to all conditions and requirements of the bid specifications; (b) price; (c) qualifications of the Bidder, including past performance, financial responsibility, general reputation, experience, service capabilities, and facilities; (d) delivery or completion date; (e) product appearance, workmanship, finish, taste, feel, overall quality, and results of product testing; (f) maintenance costs and warranty provisions; and (g) repurchase or residual value.

11. INTERPRETATION OR CORRECTION OF BIDDING DOCUMENTS

Bidder's shall promptly notify the City of any ambiguity, inconsistency, or error that they discover upon examination of the bidding documents. Interpretations, corrections, and changes will be made by addendum. Each Bidder shall ascertain prior to submitting a bid that all addenda have been received and are acknowledged in the bid.

12. INCONSISTENCIES AND OMISSIONS

These specifications and the accompanying plans, if any, are intended to include all information necessary for the work contemplated. If, by inadvertence or otherwise, the plans or specifications omit some information necessary for that purpose, the contractor shall, nevertheless, be required to perform such work at no additional cost to the City so that the project may be completed according to the true intent and purpose of the plans and specifications.

13. CONDITIONS

Bidders are advised to become familiar with all conditions, instructions, and specifications governing his or her bid. Once the award has been made, failure to have read all the conditions, instructions and specifications of this contract shall not permit the Bidder to amend contract or to request additional compensation.

14. VERIFICATIONS OF DATA

- A. It is understood and agreed that the unit quantities given in these specifications are approximate only, and the contractor shall verify these quantities before bidding as no claim shall be made against the City on, or account of, any excess or deficiency in the same.
- B. The contractor shall have visited the premises and determined for itself, by actual observation, boring, test holes, or other means, the nature of all soil and water conditions (both above and below ground in the line of work) that may be encountered in all construction work under this contract. The cost of all such inspection, borings, etc. shall be borne by the contractor, and no allowance will be made for the failure of the contractor to estimate correctly the difficulties attending the execution of the work.

15. SPECIFICATIONS

Reference to brand names and numbers is meant to be descriptive, not restrictive, unless otherwise specified. Bids on equivalent items will be considered, provided

the Bidder clearly states exactly what is proposed to be furnished, including complete specifications. Unless the Bidder specifies otherwise, it is understood the Bidder is offering a referenced brand item as specified or is bidding as specified when no brand is referenced, and does not propose to furnish an “equal.” The City reserves the right to determine whether a substitute offer is equivalent to, and meets the standard of quality indicated by the brand name and number.

16. SAMPLES

When samples of items are called for by the specifications, samples must be furnished free of expense, and if not destroyed in the evaluation process will be returned at the Bidder’s expense upon request. Request for the return of samples must accompany the sample and must include a UPS/Fed-Ex Pickup Slip, postage, or other acceptable mode of return. Individual samples must be labeled with Bidder’s name, invitation number, item reference, manufacturer’s brand name and number.

17. REGULATORY COMPLIANCE

Each Bidder represents and warrants that the goods or services furnished hereunder (including all labels, packages and containers for said goods) comply with all applicable standards, rules and regulations in effect under the requirements of all Federal, State, and local laws, rules and regulations as applicable, including the Occupational Safety and Health Act as amended, with respect to design, construction, manufacture, or use for their intended purpose of said goods or services. Each Bidder must furnish a “Material Safety Data Sheet” in compliance with the Illinois Toxic Substances Disclosure to Employees Act when required.

18. PRICING

The price quoted for each item is the full purchase price, including delivery to destination, and includes all transportation and handling charges, materials or service costs, patent royalties, and all other overhead charges of every kind and nature. Unless otherwise specified, prices shall remain firm for the contract period.

19. DISCOUNTS

Prices quoted must be net after deducting all trade and quantity discounts. Where cash discounts for prompt payment are offered, the discount period shall begin with the date of receipt of a correct invoice or receipt or final acceptance of goods, whichever is later.

20. INSPECTION

Materials or equipment purchased are subject to inspection and approval at the City’s destination. The City reserves the right to reject and refuse acceptance of items which are not in accordance with the instructions, specifications, drawings or data of Seller’s warranty (express or implied). Rejected materials or equipment shall be removed by, or at the expense of, the Seller promptly after rejection.

21. BIDS AND PLAN DEPOSITS

- A. When required on the cover sheet, all bids shall be accompanied by a bid deposit in the amount specified. Bid deposits shall be in the form of cash, a certified check, or cashier's check drawn on a responsible bank doing business in the United States and shall be made payable to the City of Evanston. Bid Bonds are also acceptable. All bids not accompanied by a bid deposit, when required, will be rejected.
- B. The City will return the bid deposits of all but the 3 lowest qualified Bidders, whose deposit will be held until contract award or at the expiration of the sixty-day or ninety-day period for bid award.
- C. The bid deposit of the successful Bidder will be retained until contract documents have been executed and the Contractor has submitted all the required information. Failure to comply with the terms of this specification may be cause for forfeiture of said deposit.
- D. When required, plan deposits will be refunded should the plans be returned in good condition within 10 days of the bid opening.

22. DISPUTES

Any dispute concerning a question of fact arising under this bid shall be decided by the Purchasing Specialist, who shall issue a written decision to the Bidder. The decision of the Purchasing Specialist shall be final and binding.

23. CATALOGS

Each Bidder shall submit, when requested by the Purchasing Specialist, catalogs, descriptive literature, and detailed drawings, fully detailing features, designs, construction, appointments, finishes and the like not covered in the specifications, necessary to fully describe the material or work proposed to be furnished.

24. TAXES

- A. Federal Excise Tax does not apply to materials purchased by the City of Evanston by virtue of Exemption Certificate No. A-208762, Illinois Retailers' Occupation Tax, Use Tax, and Municipal Retailers' Occupation Tax do not apply to materials or services purchased by the City of Evanston by virtue of Statute.
- B. The City of Evanston is exempt from Illinois Sales Tax by virtue of Exemption Identification number E9998-1750.
- C. The City's federal tax ID number is 36-6005870.

25. PERMITS & FEES

All Bidders awarded a contract must secure and pay for any licenses required by the City of Evanston. Necessary building permits will be required, but all permit fees will be waived and moneys for same must not be included in any bid.

26. ROYALTIES & PATENTS

Seller must pay all royalties and license fees. Seller must defend all suits or

claims for infringement of any patent, copyright or trademark rights, and must hold the City harmless from loss on account thereof.

27. LOCAL PREFERENCE POLICY

The Evanston City Council reserves the right to award the contract to an Evanston firm if the firm's bid is within five (5%) percent of the low bid of a non-Evanston firm.

28. POWER OF ATTORNEY

An Attorney-In-Fact, who signs any and all of the bond or contract bonds submitted with this bid, must file with each bond a certified and effectively dated copy of their Power of Attorney. These dates should be the same or after the date of the contract.

29. WARRANTY

- A. The contractor warrants that all goods and services furnished to the City shall be in accordance with specifications and free from any defects of workmanship and materials: that goods furnished to the City shall be merchantable and fit for the City's described purposes, and that no governmental law, regulation, order, or rule has been violated in the manufacture or sale of such goods.
- B. The contractor warrants all equipment furnished to be in acceptable condition, and to operate satisfactorily for a period of one (1) year from delivery of, or the completion of installation, whichever is latest, unless stated otherwise in the specifications, and that if a defect in workmanship and/or quality of materials are evidenced in this period, the Seller shall remit full credit, replace, or repair at City's discretion immediately, such equipment and/or parts that are defective at no additional cost to the City.
- C. The contractor warrants to the City that each item furnished hereunder, and any component part thereof, will be new and in conformity with the specifications in all respects, unless otherwise specified, and is of the best quality of its respective kind, free from faulty workmanship, materials, or design, and installed sufficiently to fulfill any operating conditions specified by the City.
- D. The contractor shall repair or replace any item or component part thereof found not to be in conformity with this paragraph provided the City notified the Seller of such nonconformity within one (1) year after initial use or within eighteen (18) months after delivery, whichever occurs first. In the event Seller fails to proceed diligently to so replace or repair within a reasonable time after receipt of such notice, the City may undertake or complete such replacement or repair for Seller's account, and the seller will be responsible for any additional costs. Acceptance shall not relieve the seller of its responsibility.

30. INCURRED COSTS

The City will not be liable for any costs incurred by Bidders in replying to this

invitation for bids.

31. VARIANCES

Each Bidder must state or list by reference any variations to specifications, terms and/or conditions set forth herein with its bid.

32. INDEMNIFICATION

- A. The awarded Bidder/Contractor shall defend, indemnify and hold harmless the City and its officers, elected and appointed officials, agents, and employees from any and all liability, losses, or damages as a result of claims, demands, suits, actions, or proceedings of any kind or nature, including but not limited to costs, and fees, including attorney's fees, judgments or settlements, resulting from or arising out of any negligent or willful act or omission on the part of the Contractor or Contractor's sub-contractors, employees, agents or sub-contractors during the performance of this Agreement. Such indemnification shall not be limited by reason of the enumeration of any insurance coverage herein provided. This provision shall survive completion, expiration, or termination of this Agreement.
- B. Nothing contained herein shall be construed as prohibiting the City, or its officers, agents, or employees, from defending through the selection and use of their own agents, attorneys, and experts, any claims, actions or suits brought against them. The Contractor shall be liable for the reasonable costs, fees, and expenses incurred in the defense of any such claims, actions, or suits. Nothing herein shall be construed as a limitation or waiver of defenses available to the City and employees and agents, including but not limited to the Illinois Local Governmental and Governmental Employees Tort Immunity Act, 745 ILCS 10/1-101 *et seq.*
- C. At the City Corporation Counsel's option, Contractor must defend all suits brought upon all such Losses and must pay all costs and expenses incidental to them, but the City has the right, at its option, to participate, at its own cost, in the defense of any suit, without relieving Contractor of any of its obligations under this Agreement. Any settlement of any claim or suit related to this Project by Contractor must be made only with the prior written consent of the City Corporation Counsel, if the settlement requires any action on the part of the City.
- D. To the extent permissible by law, Contractor waives any limits to the amount of its obligations to indemnify, defend, or contribute to any sums due under any Losses, including any claim by any employee of Contractor that may be subject to the Illinois Compensation Act, 820 ILCS 305/1 *et seq.* or any other related law or judicial decision, including but not limited to, *Kotecki v. Cyclops Welding Corporation*, 146 Ill. 2d 155 (1991). The City, however, does not waive any limitations it may have on its liability under the Illinois Workers Compensation Act, the Illinois Pension Code or any other statute.
- E. The Contractor shall be responsible for any losses and costs to repair or remedy work performed under this Agreement resulting from or arising out of any act or

omission, neglect, or misconduct in the performance of its Work or its sub-contractors' work. Acceptance of the work by the City will not relieve the Contractor of the responsibility for subsequent correction of any such error, omissions and/or negligent acts or of its liability for loss or damage resulting therefrom.

- F. All provisions of this Section 32 shall survive completion, expiration, or termination of this Agreement.

33. DEFAULT

Time is of the essence as to the awarded contract and, of delivery or acceptable items or rendering of services is not completed by the time promised, the City reserves the right, without liability, in addition to its other rights and remedies, to terminate the contract by notice effective when received by Seller, as to stated items not yet shipped or services not yet rendered and to purchase substitute items or services elsewhere and charge the Seller with all losses incurred. The City shall be entitled to recover its attorney's fees and expenses in any successful action by the City to enforce this contract.

34. GOVERNING LAW

This contract shall be governed by and construed according to the laws of the State of Illinois. In the event of litigation, the venue will be Cook County, Illinois.

35. EQUAL EMPLOYMENT OPPORTUNITY

- A. In the event of the contractor's noncompliance with any provision of the Illinois Human Rights Act or Section 1-12-5 of the Evanston City Code, the contractor may be declared non-responsible and therefore ineligible for future contracts or sub-contracts with the City of Evanston, and the contract may be canceled or voided in whole or in part, and such other sanctions or penalties may be imposed or remedies invoked as provided by Statute or regulation.
- B. During the performance of this contract, the contractor agrees as follows:
 - 1. That it will not discriminate against any employee or applicant for employment because of race, color, religion, sex, national origin or ancestry, or age or physical or mental handicap that does not impair ability to work, and further that it will examine all job classifications to determine if minority persons or women are underutilized and will take appropriate affirmative action to rectify any such underutilization. Contractor shall comply with all requirements of City of Evanston Code Section 1-12-5.
 - 2. That, in all solicitations or advertisements for employees placed by it or on its behalf, it will state that all applicants will be afforded equal opportunity without discrimination because of race, color, religion, sex, national origin or ancestry.
 - 3. That, if it hires additional employees in order to perform this contract, or any

portion hereof, it will determine that availability (in accordance with the Fair Employment Commission's Rules and Regulations for Public Contracts) of minorities and women in the area(s) from which it may reasonably recruit and it will hire for each job classification for which employees are hired in such a way that minorities and women are not underutilized.

4. That it will send to each labor organization or representative of workers with which it has or is bound by a collective bargaining or other agreement or understanding, a notice advising such labor organization or representative of the contractor's obligations under the Illinois Fair Employment Practices Act and the Fair Employment Practices Commission's Rules and Regulations for Public Contracts. If any such labor organization or representative fails or refuses to cooperate with the contractor in its efforts to comply with such Act and Rules and Regulations, the contractor will promptly so notify the Illinois Fair Employment Practices Commission and the contracting agency and will recruit employees from other sources when necessary to fulfill its obligations hereunder.
5. That it will submit reports as required by the Illinois Fair Employment Practices Commission's Rules and Regulations for Public Contracts, furnish all relevant information as may from time to time be requested by the Fair Employment Practices Commission or the contracting agency, and in all respects comply with the Illinois Fair Employment Practices Commission's Rules and regulations for Public Contracts.
6. That it will permit access to all relevant books, records, accounts and work sites by personnel of the contracting agency, the City Manager, the Commission and the Illinois Fair Employment Practices Commission for purposes of investigation to ascertain compliance with the Illinois Fair Employment Practices Act and the Fair Employment Practices Act and the Fair Employment Practices Commission's Rules and Regulations for Public Contract.
7. That it will include verbatim or by reference the provisions of subsections (A) through (G) of this clause in every performance sub-contract as defined in Section 2.10(b) of the Fair Employment Practices Commission's Rules and Regulations for Public Contracts so that such provisions will be binding upon every such sub-contractor; and that it will also include the provisions of subsections (A), (E), (F), and (G) in every supply sub-contract as defined in Section 2.10(a) of the Fair Employment Practices Commission's Rules and Regulations for Public Contracts so that such provisions will be binding upon every such sub-contractor. In the same manner as with other provisions of this contract, the contractor will be liable for compliance with applicable provisions of this clause by all its sub-contractors; and further it will promptly notify the contracting agency and the Illinois Fair Employment Practices Commission in the event any sub-contractor fails or refuses to comply therewith. In addition,

no contractor will utilize any sub-contractor declared by the Fair Employment Practices Commission to be non-responsible and therefore ineligible for contracts or sub-contracts with the State of Illinois or any of its political subdivisions or municipal corporations.

36. M/W/EBE GOAL

The City of Evanston has a goal of awarding 25% of its contracts to Minority-Owned, Women-Owned, and Evanston-based businesses (M/W/EBEs). All Bidders must state the proposed involvement of M/W/EBEs in completing a portion of the services required by the City by completing the attached M/W/EBE forms. Any questions regarding M/W/EBE compliance should be submitted in writing to Tammi Nunez, Purchasing Manager at tnunez@cityofevanston.org.

37. LOCAL EMPLOYMENT PROGRAM REQUIREMENTS

N/A

38. Questions

All questions related to this bid document should be submitted in writing to Linda Thomas, Purchasing Specialist at liethomas@cityofevanston.org with a copy to Chris Venatta, at cvenatta@cityofevanston.org. Only inquiries received a minimum of seven (7) working days prior to the date set for the opening of bids, will be given any consideration.

39. COORDINATION OF EXISTING SITE WITH DRAWINGS

- A. Before submitting a bid, bidders shall carefully examine the drawings and specifications, visit the site, and fully inform themselves as to all conditions and limitations.
- B. Should a bidder find discrepancies in, or omissions from the drawings or specifications, or should be in doubt as to their meaning, the bidder should at once notify the Purchasing Specialist, who will issue necessary instructions to all bidders in the form of an addendum.

40. AFFIRMATIVE ACTION IN SUB-CONTRACTING (EXCERPT FROM RESOLUTION 59-R-73)

“Contractor agrees that he shall actively solicit bids for the sub-contracting of goods or services from qualified minority businesses. At the request of the City, Contractor shall furnish evidence of his compliance with this requirement of minority solicitation. Contractor further agrees to consider the grant of sub-contracts to said minority bidders on the basis of substantially equal bids in the light most favorable to said minority businesses. Contractor further affirms that in obtaining his performance and bid bonds, he will seek out and use companies who have records of, and/or who will make commitments to, the bonding of minority contractors on a rate basis comparable to their bonding of similar non-minority contractors. The contractor may be required to submit this evidence as part of the bid or subsequent to it.”

41. COMPLIANCE WITH LAWS

- A. The bidder shall at all times observe and comply with all laws, ordinances and regulations of the Federal, State, Local and City Governments, which may in any manner affect the preparation of bids or the performance of the contract.

42. QUALIFICATION OF BIDDERS

- A. All bidders must be qualified in accordance with the instructions, procedures and methods set forth in this specification.
- B. In awarding contract, City may take into consideration, skill, facilities, capacity, experience, ability, responsibility, previous work, financial standing of bidder, amount of work being carried on by bidder, quality and efficiency of construction equipment proposed to be furnished, period of time within which proposed equipment is furnished and delivered, necessity of prompt and efficient completion of work herein described. Inability of any bidder to meet requirements mentioned above may be cause for rejection of the bid. In addition, if the project covered by this contract is a minority set-aside project, the contractor's qualifications as a minority firm will determine the eligibility of the contractor to bid.

43. COMPETENCY OF BIDDER

- A. No bid will be accepted from or contract awarded to any person, firm or corporation that is in arrears or is in default to the City of Evanston upon any debt or contract, or that is a defaulter, as surety or otherwise, upon any obligation to said City, or had failed to perform faithfully any previous contract with the City.
- B. The bidder, if requested, must present within forty eight (48) hours evidence satisfactory to the Purchasing Manager of performance ability and possession of necessary facilities, pecuniary resources and adequate insurance to comply with the terms of these specifications and contract documents.

44. PREFERENCE TO CITIZENS

The Contractor shall abide by the Illinois Preference Act, 30 ILCS 570 et seq., which stipulates that whenever there is a period of excessive unemployment in Illinois, defined as any month immediately following two (2) consecutive months during which the level of unemployment in Illinois exceeds five percent (5%) as measured by the U.S. Bureau of Labor Statistics in its monthly publication of employment and unemployment figures, the Contractor shall employ only Illinois laborers unless otherwise exempted as so stated in the Act. ("Illinois laborer" means any person who has resided in Illinois for at least 30 days and intends to become or remain an Illinois resident) Other laborers may be used IF Illinois laborers are not available or are incapable of performing the particular type of work involved if so certified by the Contractor and approved by the project engineer.

GENERAL CONDITIONS

1. BASIS OF AWARD

The City of Evanston reserves the right to award a contract to a responsive and responsible Bidder(s) who submits the lowest total bid, or to reject any or all bids and bidding, when in its opinion the best interest of the City will be served by such action. The City reserves the right to consider the specified alternates in its evaluation of the bids.

2. BIDS

UNIT PRICE BID

1. The Bidder is to submit a unit price bid for each bid line on the Bid Form which includes all costs incidental to performing the specified work.
2. It is understood and agreed that the unit quantities given in the supporting pages are approximate only and the Bidder shall verify these quantities before bidding as no claim shall be made against the City on account of any excess or deficiency in the same.
3. Unit prices given in the supporting pages shall be used by the Owner and the Contractor for any subsequent changes in the contract.
4. The quantities provided in the bid documents are approximate only and are subject to increase or decrease. Actual compensation to the CONTRACTOR shall be based upon the actual quantities multiplied by the unit prices bid for each item. The unit prices submitted herewith is for the purpose of obtaining a gross sum, and for use in computing the value of additions and deductions and for the purpose of determining the lowest BIDDER. Should there be a discrepancy between the gross sum bid and that bid resulting from summation of quantities multiplied by their respective unit prices, the latter shall apply.

3. QUANTITIES

Any quantities shown on the Bid Form are estimated only for bid canvassing purposes, the City has made a good faith effort to estimate the quantity requirements for the Contract term. The City reserves the right to increase or decrease quantities ordered under this contract.

4. CONTRACT TERM

Bidder must fully complete the work within the period specified herein after award of the contract by the City.

5. NOTICE TO PROCEED/ PURCHASE ORDER/ CONTRACT

- A. The City issued Purchase Order serves as the City official Notice to Proceed. No work will be allowed prior to Contractor receipt of the City issued Purchase Order.

- B. Upon approval of the required bonds and insurance documents, the City will issue a Purchase Order to the Contractor for the contract amount. All Applications for Payment must reference the Purchase Order number.
- C. When it is necessary to issue a Change Order that increases/decreases the contract amount, a Change Order form will be issued and a modified Purchase Order will be issued reflecting the revised contract amount.
- D. When it is necessary to issue a Change Order that only increases/decreases the contract period, only a Change Order form will be issued establishing the revised contract period.
- E. Upon Award the contractor shall execute the Contractor Services Agreement.

6. PAYMENT

- A. Progress payments will be made in accordance with “Applications for Payment” and “Project Closeout” sections of the specifications, less a 10% retainage for each payment, which will be held until final acceptance of the work by the City. Certification of each Application for Payment will be made by the City’s representative.
- B. All payments will be made in accordance with *Illinois Local Government Prompt Payment Act*.

7. DECISIONS TO WITHHOLD CERTIFICATION FOR PAYMENT

- A. The City may not certify payment and may withhold payment in whole or in part, to the extent reasonably necessary to protect the City, if the quality of the work is not in accordance with the contract documents. If the City is unable to certify payment in the amount of the invoice, the City will promptly issue payment for the amount of the Work completed in accordance with the contract documents. The City may not certify payment due to any contractor negligence or contract non-compliance.
 - a. Defective work not remedied
 - b. Third party claims filed or reasonable evidence indicating probable filing of such claims
 - c. Failure of Contractor to make payments properly to Sub-contractors for labor, materials or equipment
 - d. Reasonable evidence that the work cannot be completed for the unpaid balance of the Contract Sum
 - e. Damage to the City or another contractor
 - f. Reasonable evidence that the work will not be completed within the Contract period and that the unpaid balance would not be adequate to cover actual or liquidated damages for the anticipated delay
 - g. Persistent failure to carry out work in accordance with the Contract Documents.

8. CHANGES IN WORK

- A. The City reserves the right to make changes in the plans and specifications by altering, adding to, or deducting from the work, without invalidating the contract. All such changes shall be executed under the conditions of the original contract, except that any claim for extension of time caused thereby shall be adjusted at the time of ordering such change.
- B. No change shall be made unless a written Change Order and/or modified Purchase Order is issued by the City stating that the City has authorized the change, and no claim for an addition to the contract shall be valid unless so ordered.
- C. If such changes diminish the quantity of work to be done they shall not constitute a claim for damage or anticipated profits on the work, such increase shall be paid in one or more of the following ways:
 - 1. by estimate and acceptance in lump sum
 - 2. by unit prices named in the contract's bid form or subsequently agreed upon
- D. Whenever the quantity of any pay item as given in the proposal shall be increased or decreased, payment shall be made on the basis of the actual quantity completed at the unit price for such pay item named in the proposal.

9. DEDUCTION FOR UNCORRECTED WORK

If the City deems it expedient to correct work damaged or not done in accordance with the contract, the difference in value, together with a fair allowance for damage shall be deducted from the contract amount due. The value of such deduction shall be determined by the City.

10. CITY'S RIGHT TO TERMINATE CONTRACT

The City reserves the right, in addition to other rights to termination, to terminate the contracts in accordance with all provisions of the executed contract.

11. LIENS

- A. Neither the final payment nor any part of any retained percentages, shall become due until the contractor, if required, delivers to the City, a complete release of all liens arising out of this contract, or receipts in full in lieu thereof and, if required in either case, an affidavit that so far as it has knowledge or information the releases and receipts include all the labor and material for which a lien could be filed. If any lien remains unsatisfied after all payments are made the contractor shall refund to the City all moneys that the latter may be compelled to pay in discharging such a lien, including all costs and attorney's fees.

12. SEPARATE CONTRACTS

- A. The City reserves the right to let other contracts in connection with this work. The contractor shall afford other contractors reasonable opportunity for the introduction

and storage of their materials and the execution of their work and shall properly connect and coordinate his or her work with theirs. If any part of the contractor's work depends on proper execution or results upon the work of any other contractor, the contractor shall inspect and promptly report to the City any defects in such work that render it unsuitable for such proper execution and results. His or her failure to so inspect and report shall constitute an acceptance of other contractor's work as fit and proper.

- B. To insure the proper execution of his or her subsequent work, the contractor shall measure work already in place and shall at once report to the City any discrepancy between the executed work and the drawings which will affect his or her work.

13. PROTECTION & SAFEGUARDS

- A. Unless otherwise specified, the contractor, as a part of this contract, shall provide, erect and maintain temporary roads, fences, bracing, lights, warning signs, barricades, etc. necessary for the protection of the construction materials, adjacent property and the public.
- B. The contractor shall contact all utilities which will be affected by its operations and notify the owners of the utilities of its operations and their limits within forty-eight (48) hours prior to beginning construction. The contractor shall be responsible for damage to utilities and shall, at his or her own expense, restore such property to a condition equal to that which existed before its work, as may be directed by the owners.
- C. The contractor shall protect all work and unused materials of this contract from any and all damage and shall be solely responsible for the condition of such work and materials.

14. MATERIAL STORAGE

- A. On-site areas may be designated for material/equipment storage. The contractor will assume all risk and liability associated with the storage of material/equipment at on-site locations.

15. CLEANING UP

- A. The contractor shall at all time keep the premises free from accumulation of waste material or rubbish caused by its employees or work and at the completion of the work it shall remove all its rubbish, tools, and surplus materials from the premises, leaving the area in a neat and workmanlike condition. In case of dispute, the City may remove the rubbish and charge the cost to the contractor.
- B. Contractor recognizes that proper cleanup and removal of construction debris is an important safety consideration. The Contractor shall be solely responsible for daily construction site/area cleanup and removal of all construction debris in accordance with City-approved disposal practices. Contractor shall be solely responsible for identifying and removing at its expense all hazardous material and waste which it

uses and generates.

16. RESTORATION OF SITE

- A. Prior to final payment, contractor shall fully restore all property disturbed or damaged during the course of this work. This includes, but is not limited to public property, (walks, curbs, roadways, trees, etc.) private property, and utilities. This shall also include removal of temporary facilities erected during the course of this contract and restoration of these areas.
- B. All restoration work shall be subject to the approval of the City and shall restore the property to a condition at least equal to that existing prior to the start of this contract.
- C. All restoration work of property damaged by contractor shall be accomplished at the sole expense of the contractor.

17. PREVAILING WAGE

- A. Prospective Bidders shall thoroughly familiarize themselves with the provisions of the above-mentioned Act and shall prepare any and all bids/bids in strict compliance therewith.
- B. **Effective September 1st - All work performed on new and existing projects must be submitted to Illinois Department of Labor through the certified transcript of payroll portal.** You may access the portal here: [Certified Transcript of Payroll Portal](#)

All contractors and sub-contractors on public works projects **must submit and upload certified payrolls** on a monthly basis to the **IDOL** online portal, provide a pdf copy to the City's project manager and business work force development coordinator, along with a statement affirming that such records are true and accurate, that the wages paid to each worker are not less than the required prevailing rate and that the contractor is aware that filing records her or she knows to be false is a Class B misdemeanor.

- C. The certified payroll record must include for every worker employed on the public works project the name, address, telephone number, social security number, job classification, hourly wages paid in each pay period, number of hours worked each day, and starting and ending time of work each day. These certified payroll records are considered public records and public bodies must make these records available to the public under the Freedom of Information Act, with the exception of the employee's address, telephone number and social security number. Any contractor who fails to submit a certified payroll or knowingly files a false certified payroll is guilty of a Class B misdemeanor.
- D. All certified payrolls shall be submitted in electronic format, preferably a PDF file.
- E. As a condition of receiving payment, Contractor must (i) be in compliance with the

Agreement, (ii) pay its employees prevailing wages when required by law (Examples of prevailing wage categories include public works, printing, janitorial, window washing, building and grounds services, site technician services, natural resource services, security guard and food services). Contractor is responsible for contacting the Illinois Dept. of Labor 217-782-1710; <https://www2.illinois.gov/idol/Laws-Rules/CONMED/Pages/prevailing-wage-act.aspx> compliance with prevailing wage requirements), (iii) pay its suppliers and sub-contractors according to the terms of their respective contracts, and (iv) provide lien waivers to the City upon request.

18. CONTRACTOR REQUIREMENTS

- A. The Contractor shall abide by and comply with all local, State and federal laws and regulations relating to contracts involving public funds and the development/construction of public works, buildings, or facilities. The scale of wages to be paid shall be obtained from Illinois Department of Labor and posted by the Contractor in a prominent and accessible place at the project work site.
- B. The Contractor certifies it has not been barred from being awarded a contract with a unit of State or local government as a result of bid rigging or bid rotating or any similar offense (720 ILCS 5/33 E-3, E-4).
- C. The Contractor certifies, pursuant to the Illinois Human Rights Act (775 ILCS 5/2-105), that it has a written sexual harassment policy that includes, at a minimum, the following information: (1) the illegality of sexual harassment, (2) the definition of sexual harassment under State law, (3) a description of sexual harassment utilizing examples, (4) the Contractor's internal complaint process including penalties, (5) legal recourse, investigation and complaint process available through the Illinois Department of Human Rights and the Human Rights Commission and directions on how to contact both; and (6) protection against retaliation as provided by Section 6-101 of the Illinois Human Rights Act.
- D. The Contractor shall abide by the "Illinois Preference Act" which stipulates that whenever there is a period of excessive unemployment in Illinois, defined as any month immediately following two (2) consecutive months during which the level of unemployment in Illinois exceeds five percent (5%) as measured by the U.S. Bureau of Labor Statistics in its monthly publication of employment and unemployment figures, the Contractor shall employ only Illinois laborers unless otherwise exempted as so stated in the Act. ("Illinois laborer" means any person who has resided in Illinois for at least 30 days and intends to become or remain an Illinois resident) Other laborers may be used IF Illinois laborers are not available or are incapable of performing the particular type of work involved if so certified by the Contractor and approved by the project engineer.

19. SUB-CONTRACTORS

- A. The term "sub-contract" means any agreement, arrangement or understanding, written or otherwise between a Contractor and any person (in which the parties do not stand in the relationship of an employer or an employee) for the furnishing of

supplies or services or for the use of real or personal property, including lease arrangements, which, in whole or in part, is utilized in the performance of any one or more Contracts under which any portion of the Contractor's obligation under any one or more Contracts is performed, undertaken or assumed.

- B. The Bidder is specifically advised that any person, firm or party, to whom it is proposed to award a sub-contract under this contract must be acceptable to the City. Approval for the proposed sub-contract Award cannot be given by the City until the proposed Sub-contractor has submitted evidence showing that it has fully complied with any reporting requirements to which it is, or was, subject.
- C. The contractor, shall, within ten (10) days after award of the Contract, submit to the City in writing, names and addresses and respective amounts of money for proposed contracts with Sub-contractors/major suppliers. The City will review and may direct the Contractor that they shall not employ any that are not acceptable as provided above.
- D. The sub-contractor shall abide by and comply with all local, State and federal laws and regulations relating to contracts involving public funds and the development/construction of public works, buildings, or facilities.

20. PAYMENTS TO SUB-CONTRACTORS

- A. Within seven days after the receipt of amounts paid by the City for work performed by a sub-contractor under this contract, the Contractor shall either:
 - 1. Pay the sub-contractor for the proportionate share of the total payment received from the City attributable to the work performed by the sub-contractor under this contract; or,
 - 2. Notify the City and sub-contractor, in writing, of his intention to withhold all or a part of the sub-contractor's payment and the reason for non-payment.
- B. The Contractor shall pay interest to the sub-contractor on all amounts owed that remain unpaid beyond the seven day period except for amounts withheld as allowed in item 2 above.
- C. Unless otherwise provided under the terms of this contract, interest shall accrue at the rate of one percent per month.
- D. The Contractor shall include in each of its sub-contracts a provision requiring each Sub-contractor to include or otherwise be subject to the same payment and interest requirements as set forth above with respect to each lower-tier sub-contractor.
- E. The Contractor's obligation to pay an interest charge to a sub-contractor pursuant to this provision may not be construed to be an obligation of the City.

21. BOND – PERFORMANCE, MATERIAL, & LABOR

- A. When required by the specifications herein, the successful Bidder or Bidders shall, within ten (10) calendar days after acceptance of the Bidder's bid by the City, furnish a performance bond for 100% of the full amount of the contract from insurance companies having not less than A+ Policyholders Rating from the most recent Alfred M. Best and Co., Inc. listing available. Certification of the insurance company's rating shall be provided prior to contract implementation and quarterly thereafter until contract completion. Should such rating fall below the required A+ level during performance of the contract, it will be the contractor's responsibility to notify the City and provide a new bond from an insurance company whose rating meets the City's requirements.
- B. When required by the specifications herein, all Bidders shall submit with the bid a bid bond. A letter of credit may be furnished in lieu of a bid bond only if the following conditions are met: 1) An irrevocable letter of credit must be obtained from an accredited bank which shall include an agreement that the bank will honor a demand by the City for payment due to Plaintiff failure to complete the project. 2) An irrevocable letter of credit must be in writing and signed by an authorized representative of the bank. 3) The irrevocable letter of credit must expressly state that it is irrevocable until the bid has been awarded. 4) The letter of credit must be for the percentage specified in the bid documents.
- C. The City may reject the use of an irrevocable letter of credit if the financial soundness of the issuing bank is found to be unacceptable.
- D. In the event that the Bidder fails to furnish a performance bond in said period of ten (10) calendar days after acceptance of the Bidder's bid by the City, the City may withdraw its acceptance of the bid and retain the Bidder's deposit as liquidated damages and not as a penalty.
- E. If the contractor has more than one project for which there is a contract with the City of Evanston the contractor shall provide a separate Performance Bond for each project.

22. INDEMNITY

- A. The Contractor shall defend, indemnify and hold harmless the City and its officers, elected and appointed officials, agents, and employees from any and all liability, losses, or damages as a result of claims, demands, suits, actions, or proceedings of any kind or nature, including but not limited to costs, and fees, including attorney's fees, judgments or settlements, resulting from or arising out of any negligent or willful act or omission on the part of the Contractor or Contractor's sub-contractors, employees, agents or sub-contractors during the performance of this Agreement. Such indemnification shall not be limited by reason of the enumeration of any insurance coverage herein provided. This provision shall survive completion, expiration, or termination of this Agreement.

- B. Nothing contained herein shall be construed as prohibiting the City, or its officers, agents, or employees, from defending through the selection and use of their own agents, attorneys, and experts, any claims, actions or suits brought against them. The Contractor shall be liable for the reasonable costs, fees, and expenses incurred in the defense of any such claims, actions, or suits. Nothing herein shall be construed as a limitation or waiver of defenses available to the City and employees and agents, including but not limited to the Illinois Local Governmental and Governmental Employees Tort Immunity Act, 745 ILCS 10/1-101 *et seq.*
- C. At the City Corporation Counsel's option, Contractor must defend all suits brought upon all such Losses and must pay all costs and expenses incidental to them, but the City has the right, at its option, to participate, at its own cost, in the defense of any suit, without relieving Contractor of any of its obligations under this Agreement. Any settlement of any claim or suit related to this Project by Contractor must be made only with the prior written consent of the City Corporation Counsel, if the settlement requires any action on the part of the City.
- D. To the extent permissible by law, Contractor waives any limits to the amount of its obligations to indemnify, defend, or contribute to any sums due under any Losses, including any claim by any employee of Contractor that may be subject to the Illinois Workers Compensation Act, 820 ILCS 305/1 *et seq.* or any other related law or judicial decision, including but not limited to, *Kotecki v. Cyclops Welding Corporation*, 146 Ill. 2d 155 (1991). The City, however, does not waive any limitations it may have on its liability under the Illinois Worker Compensation Act, the Illinois Pension Code or any other statute.
- E. The Contractor shall be responsible for any losses and costs to repair or remedy work performed under this Agreement resulting from or arising out of any act or omission, neglect, or misconduct in the performance of its Work or its sub-contractors' work. Acceptance of the work by the City will not relieve the Contractor of the responsibility for subsequent correction of any such error, omissions and/or negligent acts or of its liability for loss or damage resulting therefrom.

23. CONTRACTOR'S LIABILITY INSURANCE

- A. THE CONTRACTOR SHALL NOT COMMENCE WORK UNDER THIS CONTRACT UNTIL THEY HAVE OBTAINED ALL INSURANCE REQUIRED HEREIN AND SUCH INSURANCE HAS BEEN APPROVED BY THE CITY. Nor shall the contractor allow any sub-contractor to commence work until all similar insurance required of the sub-contractor has been so obtained.
- B. The City of Evanston shall be named as an additional insured on the policy of the contractor for whatever the policy limits are for the contractor, but in no event shall the Comprehensive General Liability limits be less than \$3,000,000.00.

- C. If the contractor has more than one project for which he has a contract with the City of Evanston there shall be separate Certificates of Insurance naming the City as an additional insured on each separate policy.
- D. In the event of accidents, injuries, or unusual events, whether or not any injury occurred, the contractor shall promptly furnish the City with copies of all reports of such incidents.
- E. The contractor shall furnish one (1) copy of a certificate, with the City named as an additional insured, showing the following minimum coverage with insurance company acceptable to the City.

24. PRE-CONSTRUCTION MEETING

- A. A pre-construction meeting will be scheduled for the successful Contractor at a date immediately following awarding of the Contracts.

25. LIQUIDATED DAMAGES

- A. The Contractor must commence work within 10 days of notice from the City and the work must be completed by 8/31/2022. In the event the work is not substantially completed by the interim and final dates as detailed in the Completion Dates section of the Contract Specifications, then in addition to any remedies available to the City, the Contractor will pay to the City the sum of \$ **Seven Hundred and Fifty Dollars** per day for each calendar day beyond those dates, until substantial completion of the work has been achieved. This payment is for liquidated damages, in addition to any other damages that may be incurred by the City, and not as a penalty. All such liquidated damages may be set-off against any moneys that may be due the contractor.
- B. Substantial Completion shall be defined as the stage in the progress of the work when the work or designated portion thereof is sufficiently complete in accordance with the Contract Documents so that the City can occupy or utilize the work for its intended use. Substantial Completion will be certified by the issuance of a Certificate of Substantial Completion, to be issued by the City's representative, when the Contractor has satisfied the above statement and billed the City for a minimum of 90% of the total value of the work.

26. EXTENSION OF TIME

- A. Delays due to causes beyond the control of the contractor other than such as reasonable would be expected to occur in connection with or during the performance of the work, may entitle the contractor to an extension of time for completing the work sufficient to compensate for such delay. No extension of time shall be granted, however, unless the contractor shall notify the City in writing thereof, within ten (10) days from the initiation of the delay and unless he shall, within ten (10) days after the expiration of the delay, notify the City in writing of the extension of time claimed on account thereof and then only to the extent, if any, allowed by the City.

27. DEFAULT

- A. The City may, subject to the provisions of this section, by written notice of default to Contractor, terminate the whole or any part of this contract in any one of the following circumstances:
1. if the Contractor fails to perform the services within the time specified herein, or any extension thereof; or
 2. if the contractor fails to perform any of the other provisions of this contract, or so fails to make progress as to endanger performance of this contract in accordance with its terms, and in either of these two circumstances does not cure failure within a period of 10 days (or such other extended period as the City may authorize in writing) after receipt of notice from the City specifying such failure
- B. In the event the City terminates this contract in whole or in part as provided in this section, the City may procure, upon such terms and in such manner as the City may deem appropriate, services similar to those so terminated, and the Contractor will be liable to the City for any excess costs for such similar services.
- C. The Contractor will not be liable for any excess of costs if acceptable evidence has been submitted to the City that the failure to perform the contract was due to causes beyond the control and without fault or negligence of the Contractor.
- D. Contractors who default may not be considered for awards of future City contracts.

28. USE OF PREMISES

- A. The contractor shall confine his apparatus, the storage of materials and the operations of his workers, to limits indicated by law, ordinances, permits or directions of the City.

29. DISCLOSURES AND POTENTIAL CONFLICTS OF INTEREST (30 ILCS 500/50-35)

- A. The City of Evanston's Code of Ethics prohibits public officials or employees from performing or participating in an official act or action with regard to a transaction in which he has or knows he will thereafter acquire an interest for profit, without full public disclosure of such interest. This disclosure requirement extends to the spouse, children and grandchildren, and their spouses, parents and the parents of a spouse, and brothers and sisters and their spouses.

To ensure full and fair consideration of all bids, the City of Evanston requires all Bidders including owners or employees to investigate whether a potential or actual conflict of interest exists between the Bidder and the City of Evanston, its officials, and/or employees. If the Bidder discovers a potential or actual conflict of interest, the Bidder must disclose the conflict of interest in its bid, identifying the name of the City of Evanston official or employee with whom the conflict may exist, the

nature of the conflict of interest, and any other relevant information. The existence of a potential or actual conflict of interest does NOT, on its own, disqualify the disclosing Bidder from consideration. Information provided by Bidders in this regard will allow the City of Evanston to take appropriate measures to ensure the fairness of the bidding process.

The City of Evanston requires all bidders to submit a certification, enclosed with this bid packet, that the bidder has conducted the appropriate investigation and disclosed all potential or actual conflicts of interest.

By submitting a bid, all Bidders acknowledge and accept that if the City of Evanston discovers an undisclosed potential or actual conflict of interest, the City of Evanston may disqualify the Bidder and/or refer the matter to the appropriate authorities for investigation and prosecution.

INSURANCE REQUIREMENTS

<u>TYPE OF INSURANCE</u>	<u>MINIMUM</u>	<u>INSURANCE</u>	<u>COVERAGE</u>
	Consequent Death		Bodily Injury and Property Damage
	Each Occurrence		Aggregate
Commercial General Liability including:	\$3,000,000		\$3,000,000
1. Comprehensive form			
2. Premises - Operations			
3. Explosion & Collapse Hazard			
4. Underground Hazard			
5. Products/Completed Operations Hazard			
6. Contractual Insurance – With an endorsement on the face of the certificate that it includes the "Indemnity" paragraph of the specifications.			
7. Broad Form Property Damage - construction projects only			
8. Independent contractors			
9. Personal Injury			
Automobile Liability Owned, Non-owned or Rented	\$ 1,000,000		\$1,000,000
Workmen's Compensation and Occupational Diseases As required by applicable laws. Employer's Liability			\$ 500,000

**Insurance Certificate Must State:
The City Of Evanston is Named
as Additional Insured**

Thirty day notice of cancellation required on all certificates.

EXHIBIT A – BID FORM
For
2022 CDBG Sidewalk Improvements and Gap Infill

(BID #22-27)

1.01 BID TO:

THE CITY OF EVANSTON
2100 Ridge Avenue
Evanston, Illinois 60201

Hereinafter called "OWNER".

1.02 BID FROM:

(Hereinafter call "BIDDER")

Address

Telephone Number

Fax Number

1.03 BID FOR: **2022 CDBG Sidewalk Improvements and Gap Infill**

1.04 ACKNOWLEDGEMENT:

A. The Bidder, in compliance with the Invitation for Bids, having carefully examined the Drawings and Project Manual with related documents and having visited the site of the proposed Work, and being familiar with all of the existing conditions and limitations surrounding the construction of the proposed project, including the structure of the ground, subsurface conditions, the obstacles which may be encountered, local restrictions, and all other relevant matters concerning the Work to be performed, hereby PROPOSES to perform everything required to be performed, and to provide all labor, materials, necessary tools and equipment, expendable equipment, all applicable permits and taxes and fees, and provide all utility and transportation services necessary to perform and complete in a workmanlike

manner the Project in accordance with all the plans, specifications and related Contract Documents as prepared by the City of Evanston.

- B. The undersigned hereby acknowledges receipt of Invitation of Bids, Instruction to Bidder, the Project Manual, Drawings, and other Contract Documents and acknowledges receipt of the following Addenda:

Addendum No. _____ Dated _____

Addendum No. _____ Dated _____

Addendum No. _____ Dated _____

1.05 GENERAL STATEMENTS

- A. The undersigned has checked all of the figures contained in this proposal and further understands that the Owner will not be responsible for any errors or omissions made therein by the undersigned.
- B. It is understood that the right is reserved by the Owner to reject any or all proposals, to waive all informality in connection therewith and to award a Contract for any part of the work or the Project as a whole.
- C. The undersigned declares that the person(s) signing this proposal is/are fully authorized to sign on behalf of the named firm and to fully bind the named firm to all the conditions and provisions thereof.
- D. It is agreed that no person(s) or company other than the firm listed below or as otherwise indicated hereinafter has any interest whatsoever in this proposal or the Contract that may be entered into as a result thereof, and that in all respects the proposal is legal and fair, submitted in good faith, without collusion or fraud.
- E. It is agreed that the undersigned has complied and/or will comply with all requirements concerning licensing and with all other local, state and national laws, and that no legal requirement has been or will be violated in making or accepting this proposal, in awarding the Contract to him, and/or in the prosecution of the Work required hereunder.
- F. To be considered a bona fide offer, this proposal must be completed in full and accompanied by a bid deposit or a bid bond when required by Contract Documents or Addenda.

1.06 ALTERNATES

- A. When alternate proposals are required by Contract Documents or Addenda thereto, the undersigned proposes to perform alternates for herein stated additions to or deductions from hereinbefore stated Base Bid. Additions and deductions include all modifications of Work or additional Work that the undersigned may be required to perform by reason of the acceptance of alternates.

1.07 ALLOWANCE

A. N/A

1.08 AGREEMENT

- A. In submitting this Bid, the undersigned agrees:
1. To hold this Bid open for sixty (60) days from submittal date.
 2. To enter into and execute a Contract with the Owner within ten (10) days after receiving Notice of Award from the Owner.
 3. To accomplish the work in accordance with the Contract Documents.
 4. To complete the work by the time stipulated in the General Conditions
- B. The Owner reserves the right to reject any and all Bids and to waive any informalities in Bidding.

1.09 SCHEDULE

A. See General Conditions for required schedule of completion dates.

1.10 PROPOSED PRICES

A. The Bidder hereby proposes to furnish all labor, materials, equipment, transportation, construction plant and facilities necessary to complete, in a workmanlike manner and in accordance with the contract documents, the contract of work bid upon herein for compensation in accordance with the following prices:

TOTAL BASE BID AMOUNT: \$ _____

1.11 UNIT PRICING LIST

The undersigned submits the following UNIT PRICING LIST to be performed as shown on the Plans and/or described in the Specifications, and agrees that items of work not specifically mentioned in the Schedule which are necessary and required to complete the work intended shall be done incidental to and as part of the work for which a unit price is given, and understands that no additional payment will be made for such incidental work from the estimated quantities shown below. Unit prices for individual line items shall be used for the project's schedule of values, pay applications and will also be used to determine the amount to ADD TO or DEDUCT FROM the contract LUMP SUM PRICE for properly authorized additional or deducted work. In the event of a change to the contract the contractor shall be limited to markup percentages as indicated in Section 01028, 1.05, A. Bidders shall examine plans and determine actual work items and quantities for the work involved for bid analysis by the Owner.

SCHEDULE OF PRICES

(For complete information covering these items, see Plans and Contract Specifications)

LOCATION	TOTAL COST
Foster Street Sidewalk Gap Infill	
CDBG Sidewalk Improvements	
BIDDER'S PROPOSAL FOR MAKING ENTIRE IMPROVEMENTS :	

Foster Street Sidewalk Gap Infill

Item No.	Item	Unit	Quantity	Unit Price	Cost
1	TREE TRUNK PROTECTION	EACH	2		
2	TREE ROOT PRUNING	FOOT	80		
3	EARTH EXCAVATION	CU YD	90		
4	TOPSOIL FURNISH AND PLACE, 4"	SQ YD	565		
5	SODDING, SALT TOLERANT	SQ YD	565		
6	AGGREGATE BASE COURSE, TYPE B 4"	SQ YD	266		
7	INCIDENTAL HOT-MIX ASPHALT SURFACING	TON	5		
8	PORTLAND CEMENT CONCRETE DRIVEWAY PAVEMENT, 6 INCH	SQ YD	28		
9	PORTLAND CEMENT CONCRETE DRIVEWAY PAVEMENT, 8 INCH	SQ YD	120		
10	PORTLAND CEMENT CONCRETE SIDEWALK, 5 INCH	SQ FT	4,270		
11	DETECTABLE WARNINGS	SQ FT	180		
12	HOT-MIX ASPHALT SURFACE REMOVAL, 1.5"	SQ YD	36		
13	DRIVEWAY PAVEMENT REMOVAL	SQ YD	148		
14	COMBINATION CURB AND GUTTER REMOVAL	FOOT	130		
15	SIDEWALK REMOVAL	SQ FT	2,215		
16	COMBINATION CONCRETE CURB AND GUTTER, TYPE B-6.12	FOOT	146		
17	CHAIN LINK FENCE REMOVAL AND REPLACEMENT, 4-FOOT	FOOT	100		
18	CHAIN LINK FENCE DOUBLE SWING GATE, 12-FEET	EACH	1		
19	NON-SPECIAL WASTE DISPOSAL	CU YD	90		
20	SPECIAL WASTE PLANS AND REPORTS	LSUM	1		

21	SOIL DISPOSAL ANALYSIS	EACH	2		
22	MOBILIZATION	LSUM	1		
23	TRAFFIC CONTROL AND PROTECTION	LSUM	1		
24	THERMOPLASTIC PAVEMENT MARKING - LINE 6"	FOOT	50		
25	THERMOPLASTIC PAVEMENT MARKING - LINE 24"	FOOT	12		
26	STREET SWEEPING	EACH	2		
27	CONSTRUCTION LAYOUT	LSUM	1		
Foster Street Sidewalk Gap Infill:					

CDBG Sidewalk Improvements

Item No.	Item	Unit	Quantity	Unit Price	Cost
1	EARTH EXCAVATION	CU YD	50		
2	TOPSOIL FURNISH AND PLACE, 4"	SQ YD	500		
3	SODDING, SALT TOLERANT	SQ YD	500		
4	AGGREGATE BASE COURSE, TYPE B 4"	SQ YD	50		
5	INCIDENTAL HOT-MIX ASPHALT SURFACING	TON	10		
6	PORTLAND CEMENT CONCRETE DRIVEWAY PAVEMENT, 6 INCH	SQ YD	50		
7	PORTLAND CEMENT CONCRETE DRIVEWAY PAVEMENT, 8 INCH	SQ YD	50		
8	PORTLAND CEMENT CONCRETE SIDEWALK, 5 INCH	SQ FT	5,000		
9	DETECTABLE WARNINGS	SQ FT	120		
10	HOT-MIX ASPHALT SURFACE REMOVAL, 1.5"	SQ YD	45		
11	DRIVEWAY PAVEMENT REMOVAL	SQ YD	100		
12	CURB REMOVAL	FOOT	100		
13	COMBINATION CURB AND GUTTER REMOVAL	FOOT	100		
14	SIDEWALK REMOVAL	SQ FT	5,000		
15	CONCRETE CURB, TYPE B	FOOT	100		
16	COMBINATION CONCRETE CURB AND GUTTER, TYPE B-6.12	FOOT	100		
17	BRICK PAVER REMOVAL AND REPLACEMENT	SQ FT	50		
CDBG Sidewalk Improvements:					

1.12 BID SECURITY

If required by the bid documents, a scanned copy of the bid bond must be included with the bid electronic submission. The City is currently not able to accept a certified check, bank cashier's check or electronic bid bond at this time.

- A. The City of Evanston Civic Center is unable to receive in person drop-off and it is closed to the public. The original bid bond must be mailed within ten (10) days after the due date, to the City of Evanston Purchasing Department, 2100 Ridge Avenue - Room 4200 Evanston, Illinois 60201 Attention Purchasing Manager using the USPS (certified or priority), UPS or FedEx mail options in order to have a tracking number.
- B. Accompanying this electronic submittal is a scanned copy of a bank draft, bid bond, Cashier's check or Certified check as surety in the amount of not less than five percent (5%) of the Total Bid payable to the City of Evanston.

The amount of the check or draft is: \$ _____

If this bid is accepted and the undersigned shall fail to execute a contract and contract bond as required it is hereby agreed that the amount of the check or draft or bidder's bond substituted in lieu thereof, shall become the property of the City and shall be considered as payment of damages due to delay and other causes suffered by the City because of the failure to execute said contract and contract bond; otherwise said check or draft shall be returned to the undersigned.

In the event that one check or draft is intended to cover two or more bids, the amount must be equal to the sum of the project proposal guarantees of the individual sections covered.

If the check or draft is placed on another project proposal, state below where it may be found, as follows: The check or draft will be found in the project proposal for: _____.

1.13 PERFORMANCE/PAYMENT BOND

The undersigned bidder agrees to provide Performance Bond and Payment Bond executed in accordance with Contract Performance Bond form furnished by and acceptable to the Owner written with _____

in the amount of 100% of the Contract Sum (Total Base Bid and all accepted alternatives and adjustments) the cost of which is included in the Bid.

Cost of bond for change order is _____ percent of change order cost.

1.14 LIQUIDATED DAMAGES

The undersigned Bidder understands and agrees to the provisions stated under "LIQUIDATED DAMAGES" in the General Conditions and shall be assessed at the specified daily rate for each calendar day or partial calendar day until completion as defined herein.

1.15 MATERIAL SUBSTITUTION SHEET

The following is a schedule of substitute materials I propose to furnish on this job, with the difference in price being added to or deducted from the Base Bid. The Base Bid is understood to include only those items which are definitely specified by trade names or otherwise.

I understand that if no price difference is indicated, then the selection of materials is optional with the Owner, and approval or rejection of the substitution below will be indicated prior to signing of Contracts.

<u>PRODUCT NAME AND/OR MANUFACTURER</u>	<u>ADD</u>	<u>DEDUCT</u>
_____	_____	_____
_____	_____	_____
_____	_____	_____

1.16 PROPOSAL SIGNATURE (REQUIRED)

A. SOLE PROPRIETOR
Signature of Bidder: _____

SUBSCRIBED AND SWORN to before me this _____ day of _____, 20__

Notary Public

Commission Expires: _____

B. PARTNERSHIP
Signature of All Partners: _____

Name (typed or printed)

Name (typed or printed)

SUBSCRIBED AND SWORN to before me this ____ day of _____, 20__

_____ Commission Expires: _____

Notary Public

C. CORPORATION

Signature of Authorized Official: _____

Title: _____

Name above (typed or printed): _____

(If other than the president, attach a certified copy of that section of corporate by-laws or other authorization by the Corporation which permits the person to execute the offer for the Corporation.)

(Corporate Seal)

Attest: _____

Secretary

SUBSCRIBED AND SWORN to before me this ____ day of _____, 20__

_____ Commission Expires: _____

Notary Public

1.17 DISCLOSURE

- A. The undersigned duly sworn deposes and says on oath that the bidder has withheld no disclosures of ownership interest and the information provided herein to the best of its knowledge is current and said undersigned has not entered into any agreement with any other bidder or prospective bidder or with any other person, firm or corporation relating to the price named in said proposal or any other proposal, nor any agreement or arrangement under which any person, firm or corporation is to refrain from bidding, nor any agreement or arrangement for any act or omission in restraint of free competition among bidders and has not disclosed to any person, firm or corporation the terms of this bid or the price named herein.

Bidder: _____

Business Address: _____

Telephone Number: _____

1.18 CONTACTS

- A. In the event the Evanston City Council approves this bid response, list the name, address, telephone, and fax number of the person to be contacted:

Bidder: _____

Address: _____

Telephone Number: _____

Fax Number: _____

1.19 REFERENCES

A. Provide three (3) references for which your firm has completed work of a similar scope in the past.

1. Name: _____

Address: _____

Contact Person: _____

Phone: _____

Contract Value: _____

Contract Dates: _____

2. Name: _____

Address: _____

Contact Person: _____

Phone: _____

Contract Value: _____

Contract Dates: _____

3. Name: _____

Address: _____

Contact Person: _____

Phone: _____

Contract Value: _____

Contract Dates: _____

EXHIBIT B

City of Evanston M/W/EBE Policy

A City of Evanston goal is to provide contracting and sub-contracting opportunities to Minority Business Enterprises, Women Business Enterprises, and Evanston Business Enterprises. The goal of the Minority, Women and Evanston Business Enterprise Program (M/W/EBE) is to assist such businesses with opportunities to grow. To assist such growth, the City's goal is to have general contractors utilize M/W/EBEs to perform no less than 25% of the awarded contract.

Firms bidding on projects with the City must work to meet the 25% goal or request a waiver from participation. It is advised that bidders place advertisements requesting sub-contractors and that they email or contact individual firms that would be appropriate to partner in response to the project. For samples of possible advertisements, see the City of Evanston's Business Diversity Section <http://www.cityofevanston.org/business/business-diversity/> ([Sample Advertisement](#)). If you request a paper copy of the additional documents, it will be available free of charge from the Purchasing Office, 2100 Ridge Road Suite 4200, Evanston, IL 60201.

If a bidder is unable to meet the required M/W/EBE goal, the Bidder must seek a waiver or modification of the goal on the attached forms. Bidder must include:

1. A narrative describing the Bidder's efforts to secure M/W/EBE participation prior to the bid opening.
2. Documentation of each of the assist agencies that were contacted, the date and individual who was contacted, and the result of the conversation (see form)
3. A letter attesting to instances where the bidder has not received inquiries/proposals from qualified M/W/EBEs
4. Names of owners, addresses, telephone numbers, date and time and method of contact of qualified M/W/EBE who submitted a proposal but was not found acceptable.
5. Names of owners, addresses, telephone numbers, date and time of contact of at least 15 qualified M/W/EBEs the bidder solicited for proposals for work directly related to the Bid prior to the bid opening (copies must be attached).

If a bidder is selected with a Sub-contractor listed to meet the M/W/EBE goal, a "monthly utilization report" will be due to the City prior to each payment being issued to the Contractor. This report will include documentation of the name of the firm hired, the type of work that firm performed, etc. Should the M/W/EBE not be paid according to the schedule proposed in this document, the City reserves the right to cancel the contract. Examples of this monthly form can be found on the City's website: <http://www.cityofevanston.org/business/business-diversity/> ([MWEBE Monthly Utilization Report](#)).

EXHIBIT C

M/W/EBE PARTICIPATION COMPLIANCE FORM

I do hereby certify that

_____ (Name of firm) intends to participate as a Sub-contractor or General Contractor on the project referenced above.

This firm is a (check only one):

- _____ Minority Business Enterprise (MBE), a firm that is at least 51% managed and controlled by a minority, certified by a certifying agency within Illinois.
- _____ Women's Business Enterprise (WBE), a firm that is at least 51% managed and controlled by a woman, certified by a certifying agency within Illinois.
- _____ Evanston Based Enterprise (EBE), a firm located in Evanston for a minimum of one year and which performs a "commercially useful function".

Total proposed price of response \$ _____

Amount to be performed by a M/W/EBE \$ _____

Percentage of work to be performed by a M/W/EBE _____ %

Information on the M/W/EBE Utilized:

Name _____

Address _____

Phone Number _____

Signature of firm attesting to participation _____

Title and Date _____

Please attach

1. Proper certification documentation if applying as an M/WBE and check the appropriate box below. This M/WBE will be applying with documentation from:

- Cook County State Certification
- Federal Certification Women's Business Enterprise National Council
- City of Chicago Chicago Minority Supplier Development Council

2. Attach business license if applying as an EBE

EXHIBIT D

M/W/EBE PARTICIPATION WAIVER REQUEST

I am _____ of _____, and I have authority to
(Title) (Name of Firm)

execute this certification on behalf of the firm. I _____ do
(Name)

hereby certify that this firm seeks to waive all or part of this M/W/EBE participation goal for the following reason(s):

(CHECK ALL THAT APPLY. SPECIFIC SUPPORTING DOCUMENTATION MUST BE ATTACHED.)

_____ 1. No M/W/EBEs responded to our invitation to bid.

_____ 2. An insufficient number of firms responded to our invitation to bid.

For #1 & 2, please provide a narrative describing the outreach efforts from your firm and proof of contacting at least 15 qualified M/W/EBEs prior to the bid opening. Also, please attach the accompanying form with notes regarding contacting the Assist Agencies.

_____ 3. No sub-contracting opportunities exist.

Please provide a written explanation of why sub-contracting is not feasible.

_____ 4. M/W/EBE participation is impracticable.

Please provide a written explanation of why M/W/EBE participation is impracticable.

Therefore, we request to waive _____ of the 25% utilization goal for a revised goal of _____%.

Signature: _____
(Signature)

Date: _____

EXHIBIT E

Construction Contractors' Assistance Organizations ("Assist Agencies") Form

AGENCY	DATE CONTACTED	CONTACT PERSON	RESULT OF CONVERSATION
Association of Asian Construction Enterprises (AACE) 5500 Touhy Ave., Unit K Skokie, IL. 60077 Phone: 847-5259693 Perry Nakachii, President			
Black Contractors United (BCU) 400 W. 76th Street Chicago, IL 60620 Phone: 773-483-4000; Fax: 773-483-4150 Email: bcunewera@ameritech.net			
Chicago Minority Business Development Council 105 West Adams Street Chicago, Illinois 60603 Phone: 312-755-8880; Fax: 312-755-8890 Email: info@chicagomsdc.org Shelia Hill, President			
Evanston Minority Business Consortium, Inc. P.O. Box 5683 Evanston, Illinois 60204 Phone: 847-492-0177 Email: embcinc@aol.com			
Federation of Women Contractors 5650 S. Archer Avenue Chicago, Illinois 60638 Phone: 312-360-1122; Fax: 312-360-0239 Email: FWCChicago@aol.com Contact Person: Beth Doria Maureen Jung, President			
Hispanic American Construction Industry (HACIA) 901 W. Jackson, Suite 205 Chicago, IL 60607 Phone: 312-666-5910; Fax: 312-666-5692 Email: info@haciaworks.org			
Women's Business Development Ctr. 8 S. Michigan Ave, Suite 400 Chicago, Illinois 60603 Phone: 312-853-3477 X220; Fax: 312-853-0145 Email: wbdc@wbdc.org Carol Dougal, Director			

PLEASE NOTE: Use of Construction Contractor's Assistance Organization (Assist Agencies") Form and agencies are for use as a resource only. The agencies and or vendors listed are not referrals or recommendations by the City of Evanston.

EXHIBIT G

**CERTIFICATION OF BIDDER REGARDING
EQUAL EMPLOYMENT OPPORTUNITY
(Only if Contract Exceeds \$10,000)**

This certification is required pursuant to Executive Order 11246 (30 F.R. 12319-25). The implementing rules and regulations provide that any bidder or prospective contractor, or any of their proposed sub-contractors, shall state as an initial part of the bid or negotiations of the contract whether it has participated in any previous contract or sub-contract subject to the equal opportunity clause; and, if so, whether it has filed all compliance reports due under applicable instructions.

Where the certification indicates that the bidder has not filed a compliance report due under applicable instructions, such bidder shall be required to submit a compliance report within seven calendar days after bid opening. No contract shall be awarded unless such report is submitted.

CERTIFICATION OF BIDDER

Name and Address of Bidder (Include ZIP Code)

IRS EMPLOYER I.D. NUMBER 36-_____

1. Bidder has participated in a previous contract or sub-contract subject to the Equal Opportunity Clause. ___Yes ___No

2. Bidder has filed all compliance reports due under applicable instructions. ___Yes ___No

3. Have you ever been or are you being considered for sanction due to violation of Executive Order 11246, as amended? ___Yes ___No

Name: _____

Title: _____

Signature: _____

Date: _____

EXHIBIT H

DISCLOSURE OF OWNERSHIP INTERESTS

City of Evanston Ordinance 15-0-78 requires all persons (APPLICANT) seeking to do business with the City to provide the following information with their bid. Every question must be answered. If the question is not applicable, answer with "NA".

APPLICANT NAME: _____

APPLICANT ADDRESS: _____

TELEPHONE NUMBER: _____

FAX NUMBER: _____

APPLICANT is (**Check One**)

- 1. Corporation () 2. Partnership () 3. Sole Owner () 4. Association ()
- 5. Other () _____

Please answer the following questions on a separate attached sheet if necessary.

SECTION I - CORPORATION

1a. Names and addresses of all Officers and Directors of Corporation.

1b. (Answer only if corporation has 33 or more shareholders.) Names and addresses of all those shareholders owning shares equal to or in excess of 3% of the proportionate ownership interest and the percentage of shareholder interest. (Note: Corporations which submit S.E.C. form 10K may substitute that statement for the material required herein.)

1c. (Answer only if corporation has fewer than 33 shareholders.) Names and addresses of all shareholders and percentage of interest of each herein. (Note: Corporations which submit S.E.C. form 10K may substitute that statement for the material requested herein.)

SECTION 2 - PARTNERSHIP/ASSOCIATION/JOINT VENTURE

2a. The name, address, and percentage of interest of each partner whose interests therein, whether limited or general is equal to or in excess of 3%.

2b. Associations: The name and address of all officers, directors, and other members with 3% or greater interest.

SECTION 3 - TRUSTS

3a. Trust number and institution.

3b. Name and address of trustee or estate administrator.

3c. Trust or estate beneficiaries: Name, address, and percentage of interest in total entity.

SECTION 4 - ALL APPLICANTS - ADDITIONAL DISCLOSURE

4a. Specify which, if any, interests disclosed in Section 1, 2, or 3 are being held by an agent or nominee, and give the name and address of principal.

4b. If any interest named in Section 1, 2, or 3 is being held by a "holding" corporation or other "holding" entity not an individual, state the names and addresses of all parties holding more than a 3% interest in that "holding" corporation or entity as required in 1(a), 1(b), 1(c), 2(a), and 2(b).

4c. If "constructive control" of any interest named in Sections 1, 2, 3, or 4 is held by another party, give name and address of party with constructive control. ("Constructive control" refers to control established through voting trusts, proxies, or special terms of venture of partnership agreements.)

I have not withheld disclosure of any interest known to me. Information provided is accurate and current.

Date

Signature of Person Preparing Statement

Title

ATTEST: _____
Notary Public

(Notary Seal)

Commission Expires: _____

EXHIBIT I

ADDITIONAL INFORMATION SHEET

Bid/Proposal Name: _____

Bid/Proposal Number #: _____

Company Name: _____

Contact Name: _____

Address: _____

City, State, Zip: _____

Telephone/FAX: # _____

E-mail: _____

Comments: _____

EXHIBIT K

MAJOR SUB-CONTRACTORS LISTING

The following Tabulation of Major Sub-contractors shall be attached and made a condition of the Bid. The Bidder expressly understands and agrees to the following provisions:

- A. If awarded a Contract as a result of this Bid, the major sub-contractors used in the prosecution of the work will be those listed below.
- B. The following list includes all sub-contractors who will perform work representing 5% (five percent) or more of the total Base Bid.
- C. The sub-contractors listed below are financially responsible and are qualified to perform the work required.
- D. The sub-contractors listed below comply with the requirements of the Contract Documents.
- E. Any substitutions in the sub-contractors listed below shall be requested in writing by the Contractor and must be approved in writing by the Owner. All pertinent financial, performance, insurance and other applicable information shall be submitted with the request for substitutions(s). Owner shall respond to such requests within 14 calendar days following the submission of all necessary information to the full satisfaction of the Owner.

<u>Category Number</u>	<u>Name of Sub-contractor</u>	<u>Address and Telephone</u>

(Attach additional sheets as required)

END OF SECTION

EXHIBIT L

CONFLICT OF INTEREST

_____, hereby certifies that it has conducted an investigation into whether an actual or potential conflict of interest exists between the Bidder, its owners and employees and any official or employee of the City of Evanston.

Bidder further certifies that it has disclosed any such actual or potential conflict of interest and acknowledges if Bidder/proposer has not disclosed any actual or potential conflict of interest, the City of Evanston may disqualify the bid/proposal.

(Name of Bidder/proposer if the Bidder/proposer is an Individual)
(Name of Partner if the Bidder/proposer is a Partnership)
(Name of Officer if the Bidder/proposer is a Corporation)

The above statements must be subscribed and sworn to before a notary public.
Subscribed and Sworn to this _____ day of _____, 20

Notary Public

(Notary Seal)

Commission Expires: _____

EXHIBIT M

SIGNATURE FORM

THE SECTION BELOW MUST BE COMPLETED IN FULL AND SIGNED

The undersigned hereby certifies that they have read and understand the contents of this solicitation and attached service agreements, and agree to furnish at the prices shown any or all of the items above, subject to all instructions, conditions, specifications and attachments hereto. Failure to have read all the provisions of this solicitation shall not be cause to alter any resulting contract or to accept any request for additional compensation. By signing this document, the proposer hereby certifies that they are not barred from bidding on this contract as a result bid rigging or bid rotating or any similar offense (720 ILCS 5/33 E-3, E-4).

Authorized Signature: _____

Company Name: _____

Typed/Printed Name: _____

Date: _____

Title: _____

Telephone Number: _____

E-mail _____

Fax Number: _____

Exhibit N

Contractor Services Agreement Acknowledgement Page

The City has attached its standard contractor services agreement as an exhibit to this bid document. Identify all exceptions to the agreement that would prevent your firm from executing it. **The City shall not consider or negotiate regarding exceptions submitted at any time after the submission of the Bidder's response.** *Please check one of the following statements:*

____ I have read the contractor services agreement and plan on executing the agreement without any exceptions.

____ My firm cannot execute the City's standard contractor service agreement unless the exceptions noted below or in the attached sample contractor services agreement are made.

*****Please be aware that submitting exceptions to the contract may impact the likelihood of your firm being selected to perform this work.**

List exceptions in the area below:

Authorized Signature: _____

Company Name: _____

Typed/Printed Name and Title: _____

Date: _____

Exhibit N

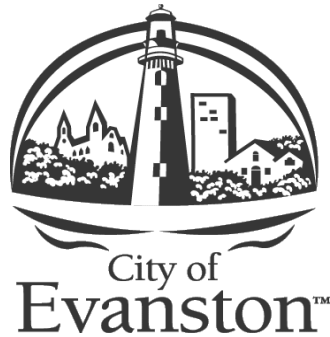

CONTRACTOR SERVICES AGREEMENT

The parties referenced herein desire to enter into an agreement for professional services for

2022 CDBG Sidewalk Improvements and Gap Infill

(BID #22-27)

THIS AGREEMENT (hereinafter referred to as the “Agreement”) is entered into between the City of Evanston, an Illinois municipal corporation with offices located at 2100 Ridge Avenue, Evanston Illinois 60201 (hereinafter referred to as the “City”), and *[Insert Contractor name here]*, with offices located at *[Insert Contractor address here]*, (hereinafter referred to as the “Contractor”). Compensation (the “Compensation”) for all basic services provided by the Contractor pursuant to the terms of this Agreement shall not exceed *[\$[Insert fee here]]*.

Revision March 2020

TABLE OF CONTENTS

1	Services and Duties of the Contractor.....	1
2	Standard Certifications.....	4
3	Additional Services/Change Orders.....	7
4	Bonds	9
5	Liquidated Damages in the Event Contractor Fails to Complete the Work.....	10
6	The City’s Responsibilities	10
7	Period of Service.....	10
8	Payment for Services and Reimbursements.....	11
9	Notice and Cure/Termination	12
10	Insurance	13
11	Indemnification	15
12	Drawings and Documents	16
13	Successors and Assigns.....	16
14	Force Majeure	16
15	Amendments and Modifications.....	17
16	Standard of Care & Warranty	17
17	Savings Clause	18
18	Non-Waiver of Rights.....	18
19	Entire Agreement	19
20	Governing Law	19
21	Ownership of Contract Documents.....	19
22	Notice.....	19
23	Severability	20
24	Execution of Agreement	20
25	Counterparts.....	20
26	Authorizations.....	20
27	Time of Essence.....	20

RECITALS

WHEREAS, the City intends to retain the services of a qualified and experienced contractor for the following:

[Insert whatever project specific background and language is appropriate]

WHEREAS, this Agreement shall include the following documents which are attached hereto:

- a) City of Evanston RFQ/RFP/Bid _____, attached as Exhibit A.
- b) Contractor's response to RFQ/RFP/Bid _____, attached as Exhibit B.
- c) Any sub-contractor sub-contracts related to this Agreement, attached as Exhibit C.

NOW, THEREFORE, in consideration of the mutual covenants hereinafter set forth, the parties agree as follows:

1 Services and Duties of the Contractor

1.1 The Contractor shall perform professional services and provide equipment (the "Work") in accordance with Exhibits A, B, and C. The Contractor retains the right to control the manner of performance of the services provided for in this Agreement and is an independent contractor and not agent or an employee of the City. All employees and sub-contractors of the Contractor shall likewise not be considered to be employees of the City. Contractor is solely responsible for the means and methods of all work performed under the terms of this Agreement for this Project ("the Project"). Contractor is an independent Contractor and is solely responsible for all taxes, withholdings, and other statutory or contractual obligations of any sort, including but not limited to, Worker's Compensation Insurance. Nothing in this Agreement accords any third-party beneficiary rights whatsoever to any non-party to this Agreement that any non-party may seek to enforce. Contractor acknowledges and agrees that should Contractor or its sub-contractors provide false information, or fail to be or remain in compliance with this Agreement; the City may void this Agreement.

1.2 The Contractor warrants and states that it has read the Contract Documents, and agrees to be bound thereby, including all performance guarantees as respects Contractor's work and all indemnity and insurance requirements. Contractor further affirms that it has visited the Project site and has become familiar with all special conditions, if any, at the Project site. Contractor shall perform the Work and its obligations under this Agreement in accordance with and subject to the Contract Documents to the full extent that each such provision is applicable to the Work. Contractor shall take necessary precautions to properly protect the Work of others, if any, from damage caused by operations under this Agreement. In addition, Contractor shall protect the work during normal and adverse weather conditions until the Project is complete and accepted by the City, or until the Contractor has fully completed its work under this Agreement. Contractor's obligations include, but

EXHIBIT N

are not limited to, placing and adequately maintaining at or about all locations of Project work, sufficient guards, barricades, lights, and enclosures to protect the Work.

1.3 The Contractor shall not have any public or private interest and shall not acquire directly or indirectly any such interest which conflicts in any manner with the performance of its services under this Agreement.

1.4 The Contractor shall designate, in writing, a person to act as its Project Manager for the work to be performed under this Agreement. Such person shall have complete authority to transmit instructions, receive information, interpret and define the Contractor's policies and decisions with respect to the work covered by this Agreement.

1.5 The Contractor shall employ only persons duly licensed by the State of Illinois to perform the professional services required under this Agreement for which applicable Illinois law requires a license, subject to prior approval of the City. The Contractor shall employ only well qualified persons to perform any of the remaining services required under this Agreement, also subject to prior approval of the City. The City reserves the right to require replacement of Contractor, sub-contractor, or supplier personnel for any reason. Contractor will replace the unacceptable personnel at no charge to the City. For all solicitations or advertisements placed by or on behalf of Contractor for employees for this Project it will state that the Contractor is an Equal Opportunity Employer.

1.6 Pursuant to the Illinois Freedom of Information Act, 5 ILCS 140/7(2), records in the possession of others whom the City has contracted with to perform a governmental function are covered by the Act and subject to disclosure within limited statutory timeframes (five (5) working days with a possible five (5) working day extension). Upon notification from the City that it has received a Freedom of Information Act request that calls for records within the Contractor's control, the Contractor shall promptly provide all requested records to the City so that the City may comply with the request within the required timeframe. The City and the Contractor shall cooperate to determine what records are subject to such a request and whether or not any exemption to the disclosure of such records, or part thereof, is applicable. Contractor shall indemnify and defend the City from and against all claims arising from the City's exceptions to disclosing certain records which Contractor may designate as proprietary or confidential. Compliance by the City with an opinion or a directive from the Illinois Public Access Counselor or the Attorney General under FOIA, or with a decision or order of Court with jurisdiction over the City, shall not be a violation of this Section.

1.7 The Contractor shall obtain prior approval from the City prior to sub-contracting with any entity or person to perform any of the work required under this Agreement. The Contractor may, upon request of the City, submit to the City a draft sub-contractor agreement for City review and approval prior to the execution of such an agreement. Any previously entered into sub-contractor agreement(s) are attached as Exhibit C. If the Contractor sub-contracts any of the services to be performed under this Agreement, the sub-contractor agreement shall provide that the services to be performed under any such agreement shall not be sublet, sold, transferred, assigned or otherwise disposed of to another entity or person without the City's prior written consent. The Contractor shall

be responsible for the accuracy and quality of any sub-contractor's work.

1.8 The Contractor shall cooperate fully with the City, other City contractors, other municipalities and local government officials, public utility companies, and others, as may be directed by the City. This shall include attendance at meetings, discussions and hearings as requested by the City. This cooperation shall extend to any investigation, hearings or meetings convened or instituted by OSHA relative to this Project, as necessary. Contractor shall cooperate with the City in scheduling and performing its Work to avoid conflict, delay in or interference with the work of others, if any, at the Project.

1.9 The Contractor acknowledges that it shall enforce and comply with all applicable Occupational Safety and Health Administration standards (OSHA) for this Project in effect as of the date of the execution of this Agreement, or as otherwise promulgated by OSHA in the future taking effect during the pendency of this Project. Contractor shall enforce all such standards and ensure compliance thereto as to its own agents and employees, and as to the agents and employees of any sub-contractor throughout the course of this Project. Contractor is solely responsible for enforcing and complying with all applicable safety standards and requirements on this Project, and is solely responsible for correcting any practices or procedures which do not comply with the applicable safety standards and requirements for this Project. Any Project specific safety requirements applicable to this Project must be followed by Contractor and any sub-contractor(s) on the Project. Additionally, all such safety requirements shall be made a part of any sub-contractor agreement.

1.10 The Contractor shall submit to the City a progress report each month this Agreement is in effect. The report shall include the following items:

- a) A summary of the Contractor's project activities, and any sub-contractor project activities that have taken place during the invoice period;
- b) A summary of the Contractor's project activities and any sub-contractor project activities, that shall take place during the next invoice period;
- c) A list of outstanding items due to or from the City; and
- d) A status of the Project schedule.

1.11 The Contractor shall perform the work required under this Agreement pursuant to high quality industry standards expected by the City. The Contractor shall apply for and receive all appropriate permits before performing any work in the City. The Contractor shall also provide the appropriate permit drawings for Building Permits to be issued for the Project, if said permits are obligated by the Project. The City will assist the Contractor with obtaining the appropriate building and right-of-way permits.

1.12 The Contractor shall provide drawings of record, in the following 3 electronic formats for all locations where equipment has been installed and/or work has been performed. The electronic formats required by this Section 1.12 are Auto Cad Version 2007, ArcView and PDF.

1.13 Contractor recognizes that proper cleanup and removal of construction debris is an

important safety consideration. The Contractor shall be solely responsible for daily construction site/area cleanup and removal of all construction debris in accordance with City-approved disposal practices. Contractor shall be solely responsible for identifying and removing at its expense all hazardous material and waste which it uses and generates.

1.14 To the extent that there is any conflict between a provision specified in this Agreement, with a provision specified in any of the other Contract Documents, as defined in Section 1.15, this Agreement shall control. The City and the Contractor may amend this Section 1.14 as provided by Section 15 herein.

The Contractor acknowledges and agrees that the City has no retained control over any of the Work done pursuant to this Agreement, and that the City is expressly exempt from the retained control exception as defined in the Restatement of Torts, Second, Section 414. This provision shall survive completion, expiration, or termination of this Agreement.

1.15 The Contract Documents for this Project consist of:

- a) This Agreement;
- b) The City's RFP/RFQ, and the plans, specifications, general conditions, drawings addenda, and modifications thereto;
- c) The Contractor's response to the RFP/RFQ/Bid;
- d) Other exhibits and schedules, if any, listed in this Agreement;
- e) Amendments or Other Contract Documents, if any; and
- f) Amendments/Modifications to this Agreement issued after execution thereof.

1.16 As a condition of receiving payment, Contractor must (i) be in compliance with the Agreement, (ii) pay its employees prevailing wages when required by law (Examples of prevailing wage categories include public works, printing, janitorial, window washing, building and grounds services, site technician services, natural resource services, security guard and food services). Contractor is responsible for contacting the Illinois Dept. of Labor 217-782-6206; <http://www.illinois.gov/idol/Laws-Rules/CONMED/Pages/Rates.aspx> to ensure compliance with prevailing wage requirements), (iii) pay its suppliers and sub-contractors according to the terms of their respective contracts, and (iv) provide lien waivers to the City upon request.

2 Standard Certifications

Contractor acknowledges and agrees that compliance with this section and each subsection for the term of the Agreement is a material requirement and condition of this Agreement. By executing this Agreement, Contractor certifies compliance with this section and each subsection and is under a continuing obligation to remain in compliance and report any non-compliance.

This section, and each subsection, applies to sub-contractors used on this Agreement. Contractor shall include these Standard Certifications in any sub-contract used in the performance of the Agreement.

If this Agreement extends over multiple fiscal years, Contractor and its sub-contractors shall confirm compliance with this section in the manner and format determined by the City by the date specified by the City and in no event later than January 1 of each year that this Agreement remains in effect.

If the City determines that any certification in this section is not applicable to this Agreement, it may be stricken, subject to sole approval by the City, without affecting the remaining subsections.

2.1 As part of each certification, Contractor acknowledges and agrees that should Contractor or its sub-contractors provide false information, or fail to be or remain in compliance with the Standard Certification requirements, one or more of the following sanctions will apply:

- the Agreement may be void by operation of law,
- the City may void the Agreement, and
- Contractor and its sub-contractors may be subject to one or more of the following: suspension, debarment, denial of payment, civil fine, or criminal penalty.

2.2 By signing this Agreement, the Contractor certifies that it has not been barred from being awarded a contract with a unit of State or local Government as a result of bid rigging or bid rotating or similar offense, nor has it made any admission of guilt of such conduct that is a matter of public record. (720 ILCS 5/33 E-3, E-4).

2.3 In the event of the Contractor's noncompliance with any provision of Section 1-12-5 of the Evanston City Code, the Illinois Human Rights Act or any other applicable law, the Consultant may be declared non-responsible and therefore ineligible for future contracts or sub-contracts with the City, and the contract may be cancelled or voided in whole or in part, and such other sanctions or penalties may be imposed or remedies invoked as provided by statute or regulation.

2.4 During the term of this Agreement, the Contractor agrees as follows:

- a) That it will not discriminate against any employee or applicant for employment because of race, color, religion, sex, sexual orientation, marital status, national origin or ancestry, or age or physical or mental disabilities that do not impair ability to work, and further that it will examine all job classifications to determine if minority persons or women are underutilized and will take appropriate affirmative action to rectify any such underutilization. Consultant shall comply with all requirements of City of Evanston Code Section 1-12-5.
- b) That, in all solicitations or advertisements for employees placed by it on its behalf, it will state that all applicants will be afforded equal opportunity without discrimination because of race, color, religion, sex, sexual orientation, marital status, national origin, ancestry, or disability.

2.5 The Contractor certifies pursuant to the Illinois Human Rights Act (775 ILCS 5/2105 *et. seq.*), that it has a written sexual harassment policy that includes, at a minimum, the following

EXHIBIT N

information:

- a) The illegality of sexual harassment;
- b) The definition of sexual harassment under State law;
- c) A description of sexual harassment utilizing examples;
- d) The Contractor's internal complaint process including penalties;
- e) Legal recourse, investigation and complaint process available through the Illinois Department of Human Rights and the Human Rights Commission, and directions on how to contact both; and
- f) Protection against retaliation as provided to the Department of Human Rights.

2.6 In accordance with the Steel Products Procurement Act (30 ILCS 565), Contractor certifies steel products used or supplied in the performance of a contract for public works shall be manufactured or produced in the U.S. unless the City grants an exemption.

2.7 Contractor certifies that it is properly formed and existing legal entity and as applicable has obtained an assumed name certificate from the appropriate authority, or has registered to conduct business in Illinois and is in good standing with the Illinois Secretary of State.

2.8 If Contractor, or any officer, director, partner, or other managerial agent of Contractor, has been convicted of a felony under the Sarbanes-Oxley Act of 2002, or a Class 3 or Class 2 felony under the Illinois Securities Law of 1953, Contractor certifies at least five years have passed since the date of the conviction.

2.9 Contractor certifies that if more favorable terms are granted by Contractor to any similar governmental entity in any state in a contemporaneous agreement let under the same or similar financial terms and circumstances for comparable supplies or services, the more favorable terms will be applicable under this Agreement.

2.10 Contractor certifies that it is not delinquent in the payment of any fees, fines, damages, or debts to the City of Evanston.

2.11 The Contractor certifies that all Design Professionals performing the Work under this Agreement will ensure that the Project shall be designed in conformance with the Americans with Disabilities Act of 1990, 42 U.S.C. Section 12101, *et seq.*, and all regulations promulgated thereunder. Design Professional means any individual, sole proprietorship, firm, partnership, joint venture, corporation, professional corporation, or other entity that offers services under the Illinois Architecture Practice Act of 1989 (225 ILCS 305/), the Professional Engineering Practice Act of 1989 (225 ILCS 325/), the Structural Engineering Licensing Act of 1989 (225 ILCS 340/), or the Illinois Professional Land Surveyor Act of 1989 (225 ILCS 330/).

2.12 The Contractor shall comply with all federal, state and local laws, statutes, ordinances, rules, regulations, orders or other legal requirements now in force or which may be in force during the term of this Agreement. The Contractor shall comply with the Illinois Human Rights Act, 775 ILCS 5/1-101 *et. seq.*, Title VII of the Civil Rights Act of 1964, and the Illinois Prevailing

EXHIBIT N

3 Additional Services/Change Orders

3.1 If the representative of the City responsible for the Project verbally requests the Contractor to perform additional services, the Contractor shall confirm in writing that the services have been requested and that such services are additional services. Failure of the City to respond to the Contractor's confirmation of said services within thirty (30) calendar days of receipt of the notice shall be deemed a rejection of, and refusal to pay for the additional services. Contractor shall not perform any additional services until City has confirmed approval of said additional services in writing. If authorized in writing by the City, the Contractor shall furnish, or obtain from others, additional services of the following types, which shall be paid for by the City as set forth in Section 9 of this Agreement:

- a) Additional Services due to significant changes in scope of the Project or its design, including, but not limited to, changes in size, complexity or character of construction, or time delays for completion of work when such delays are beyond the control of the Contractor;
- b) Revisions of previously approved studies, reports, design documents, drawings or specifications;
- c) Preparation of detailed renderings, exhibits or scale models for the Project;
- d) Investigations involving detailed consideration of operations, maintenance and overhead expenses for the preparation of rate schedules, earnings and expense statements, feasibility studies, appraisals and valuations, detailed quantity surveys of material and labor, and material audits or inventories required for certification of force account construction performed by the City;
- e) Services not otherwise provided for in this Agreement.

3.2 The City may, upon written notice, and without invalidating this Agreement, require changes resulting in the revision or abandonment of work already performed by the Contractor, or require other elements of the work not originally contemplated and for which full compensation is not provided in any portion of this Agreement. Any additional services, abandonment of services which were authorized by the City, or changes in services directed by the City which result in the revision of the scope of services provided for in Exhibits A, B, C, and D that cause the total Compensation due Contractor under this Agreement to exceed \$25,000 or more, or increase or decrease the contract duration by more than 30 days are subject to approval by the Evanston City Council. These actions must be addressed either in a written Change Order or in a written amendment to this Agreement approved by both parties.

3.3 Contractor acknowledges and agrees that the Public Works Construction Change Order Act, 50 ILCS 525/1 *et seq.* shall apply to all Change Orders for the Project. It is expressly understood and agreed to by Contractor that it shall not be entitled to any damages or Compensation from the City on account of delay or suspension of all or any part of the Work. Contractor acknowledges that delays are inherent in construction projects and Contractor assessed that risk and fully included that risk assessment within its contract sum specified in its Response to the City

RFP/RFQ/Bid for this Project. The City shall not compensate Contractor for work that is more difficult than the contract sum specified in its Response would reflect. Delays to minor portions of the Work will not be eligible for extensions of time.

Delays to the Project caused by labor disputes or strikes involving trades not directly related to the Project, or involving trades not affecting the Project as a whole will not be eligible for an extension of time.

The City will not grant an extension of time for a delay by the Contractor's inability to obtain materials unless the Contractor first furnishes to the City documentary proof. The proof must be provided in a timely manner in accordance with the sequence of the Contractor's operations and accepted construction schedule.

In addition to any other changes requested by City (as described in Sections 3.1 and 3.2), the Company shall be entitled to request (and the City may grant) Change Orders with respect to:

- (a) The City-caused delays;
- (b) Change in Law;
- (c) Force Majeure Events.

The foregoing events shall entitle the Contractor to a change in the Compensation for this Project, if the Contractor demonstrates that it will unavoidably incur reasonable costs as a result thereof and the Contractor provides reasonable and detailed documentary support with respect to any such price impact.

The parties agree to reasonably confer regarding any such disputes with respect to the issuance of a Change Order.

Any payment for compensable delay will only be based upon actual costs excluding, without limitation, what damages, if any, the Contractor may have reasonably avoided. The Contractor understands that this is the sole basis for recovering delay damages and explicitly waives any right to calculate daily damages for office overhead, profit, or other purported loss.

All Contractor Change Orders authorized under this Section 3 shall be made in writing. In remitting a Change Order, the Contractor must first show in writing that:

- (a) The work was outside the scope of this Agreement,
- (b) The extra work was not made necessary due to any fault of Contractor;
- (c) The circumstances said to necessitate the change in performance were not reasonably foreseeable at the time the Agreement was signed;
- (d) The change is germane to the original Agreement; and
- (e) The Change Order is in the best interest of the City and authorized by law.

Any person who fails to first obtain the City's written authorization for a Change Order commits a Class 4 felony. The written determination and the written Change Order resulting from

that determination shall be preserved in the contract's file which shall be open to the public for inspection.

The City reserves all rights and causes of action, at law or equity, to seek redress against entities or persons who violate the requirements of this Section 3. By initialing below, Contractor hereby acknowledges that it is bound by this Section 3.

Contractor's Initials: _____

3.4 The Contractor is required to include the City of Evanston as a reference whenever and wherever the Contractor provides references for similar projects for a period of one (1) year from the date of Final Acceptance by the City of the Work for this Project.

4 Bonds

4.1 Before the Scheduled Construction Commencement Date, the Contractor is required to furnish unconditional performance and payment bonds in the amount of 100% of the Compensation as security for the faithful performance and completion of all the Contractor's obligations under the Contract Documents and covering the payment of all materials used in the performance of this Agreement and for all labor and services performed under this Agreement. All Bonds shall be issued on a form acceptable to the City. The bonds must be for the entire term of the Agreement. Failure to provide these bonds shall constitute a breach of Contractor's obligations under this Agreement. Each surety providing the Bonds must have a Best's rating not less than A/X and be licensed in Illinois and shall be named in the current list of "Companies Holding Certificates of Authority as Acceptable Sureties on Federal Bonds and as Acceptable Reinsuring Companies" as published in Circular 570 as published in the Federal Register and available on the website of the U.S. Department of the Treasury, Financial Management Service, at www.fms.treas.gov/c570/c570.html. All Bonds signed by an agent must be accompanied by a certified copy of his or her authority to act. It shall be the duty of the Contractor to advise the surety or sureties of any Change Orders that result in an increase to the Compensation and to ensure that the amounts of the Bonds are updated to reflect and cover any such increases throughout the course of the Project. The cost of such Bonds shall be included within the Compensation.

4.2 If the surety behind any Bond furnished by the Contractor is declared bankrupt or becomes insolvent or its right to do business is terminated in the State or it ceases to meet any of the requirements of this Contract, the Contractor shall, within [5] five days thereafter, substitute another Bond of equivalent value and surety, both of which must be acceptable to the City. In addition, no further progress payments under the Agreement will be made by the City until the Contractor complies with the provisions of this Agreement. The Contractor shall furnish to the City proof of any required bonds and proof of required insurance as one of the conditions precedent to payment under the Agreement. Upon the request of any person or entity appearing to be a potential beneficiary of bonds covering payment or performance of obligations arising under the Contract, the Contractor shall promptly furnish a copy of the bonds or authorize a copy to be furnished. All surety Bonds provided for in this Section shall incorporate by reference this Agreement, and any language that may be in any such surety Bond which conflicts with the provisions of this Agreement that define the

scope of the surety('s) duty(ies) shall be of no force and effect.

5 Liquidated Damages in the Event Contractor Fails to Complete the Work

5.1 The parties agree that failure of Contractor to timely complete the Work required by this Agreement constitutes a default. The parties agree that this default will result in damage and injury to City. The parties further agree, however, that actual damages incurred by City as result of such default is difficult if not impossible to ascertain with any degree of certainty or accuracy. Accordingly, the parties have negotiated and have agreed that for each calendar day after written notice is delivered to Contractor and Contractor fails to cure such default, that Contractor will pay City, as and for liquidated damages, and not as a penalty, the sum of **Seven Hundred and Fifty Dollars per day**. Contractor shall reimburse the City for all costs, expenses and fees (including, without limitation, attorneys' fees), if any, paid by the City in connection with such written demand by City. Contractor stipulates and agrees that the sums payable by Contractor under this Section are reasonable under the circumstances existing as of the execution of this Agreement. This Section 5.1 is not intended to limit any direct damages that may be recoverable by City related to the Contractor's failure to complete the Work in accordance with this Agreement. There shall be no early completion bonus if the Work is completed before the substantial completion date. The City, at its option, may withhold liquidated damages from progress payments payable to Contractor before the substantial completion date.

6 The City's Responsibilities

6.1 The City may evaluate the Contractor's and any sub-contractor's performance (interim and final). Timeliness in meeting the Project schedule and the overall relationship with the Contractor are factors that will be considered in the Contractor's performance rating. An unfavorable performance rating may be a factor when future assignments are being considered.

6.2 The City makes no representation or warranty of any nature whatsoever as to the accuracy of information or documentation provided by the City to the Contractor which were generated or provided by third parties.

7 Period of Service

7.1 The Contractor shall commence work on the Project after supplying the City with the Contractor's performance and payment bonds and all required insurance documents before starting its Work on this Project. The City shall determine when the Contractor has completed the Work required pursuant to this Agreement, and shall determine the date of Final Acceptance. Contractor recognizes time is of the essence regarding its performance on this Project. Contractor shall continue to perform its obligations while any dispute concerning the Agreement is being resolved, unless otherwise directed by the City.

7.2 Each phase of the project shall be completed in accordance with the activities outlined in the City's RFQ/RFP/Bid _____, Exhibit A. Project phases include:

7.2.1 Phase X: *[Phase name here.]*

7.2.2 Phase X: *[Phase name here.]*

7.2.3 Phase X: *[Phase name here.]*

8 Payment for Services and Reimbursements

8.1 Within the first five (5) business days of each month, the Contractor shall invoice the City for Work completed during the previous month. The Contractor shall provide a detailed invoice that relates invoiced items to the Contractor's response to RFQ/RFP/Bid _____ in both quantity and unit cost. Any discrepancies in the monthly invoice shall be promptly brought to the attention of the Contractor by the City Project Manager and efforts shall be made to promptly resolve said discrepancies between the City and Contractor. In the event the City and Contractor cannot resolve invoice discrepancies, items in dispute will be removed from the invoice and the City shall approve the remainder of the invoice. Payment will be made as soon as possible following the City Council meeting in which the item appeared on the bills list, and in accordance with all applicable laws and rules of the City of Evanston and the State of Illinois.

8.2 In the event of termination by the City of this Agreement pursuant to paragraph 9.1 after completion of any phase of the basic services, fees due the Contractor for services rendered through such phase shall constitute final payment for such services, and no further fees shall be due to the Contractor. In the event of such termination by the City during any phase of the basic services, the Contractor shall be paid for services rendered on the basis of the proportion of work completed on the phase to date of termination.

8.3 The City shall have the right to withhold payment to the Contractor due to the quality of a portion or all of the work performed hereunder which is not in accordance with the requirements of this Agreement, or which is unsatisfactory, or is due to the Contractor's failure or refusal to perform any of its obligations hereunder. Compensation in excess of the total contract amount specified in this Agreement will not be allowed unless justified in the City's sole judgment and authorized in advance as provided for in Section 3 of this Agreement. Compensation for improper performance by the Contractor is disallowed.

8.4 Upon completion of the Work performed by the Contractor, prior to the submission of a request for final payment, the City and Contractor shall perform a final acceptance test and review of the Work performed and/or equipment installed pursuant to the Agreement. A punch list of items outstanding will be jointly developed by the City and Contractor. In addition, the Contractor shall submit drawings of record for the Project for the City to approve. The Contractor shall promptly resolve all punch list items to the satisfaction of the City, and shall transmit to the City in writing confirmation that all punch list items have been resolved. The City will review, and the Contractor shall modify, as necessary, any drawings of record to the satisfaction of the City. Punch list items and drawings of record must be approved by the City prior to the Contractor submitting its final invoice for payment.

8.5 The Contractor shall submit an Affidavit and a final waiver of its lien, and all final waivers of liens of any sub-contractors, suppliers, and sub-sub-contractors, if applicable, with its final invoice, stating that all obligations incurred in performance of the professional services have been paid in full. The Affidavit will also include a statement stating that the professional services were performed in compliance with the terms of the Agreement. The Affidavit and all final lien waivers shall be on a form acceptable to the City.

8.6 All Project invoices shall be sent to:

City of Evanston *[Applicable department]*
2100 Ridge Avenue
Evanston, Illinois 60201

with a copy to:

City of Evanston *[Anyone else as applicable]*
2100 Ridge Avenue
Evanston, Illinois 60201

9 Notice and Cure/Termination

9.1 In furtherance of Contractor's Work on this Project, the City and the Contractor agree that the following Notice and Cure provision in this Section 9.1 shall apply during the duration of Contractor's work on this Project, in addition to the reserved rights of the City enumerated in this Agreement as follows:

- 5.1 Liquidated Damages;
- 8.3 City's right to withhold payment;
- 16.2 Contractor's duty to revise and correct errors; and
- 16.3 Contractor's duty to respond to City's notice of errors and omissions.

The City may notify Contractor of its intent to terminate this Agreement within (7) seven calendar days of issuance by the City of written notice to Contractor's Project Manager regarding defects in the Project or in Contractor's Work. The City shall specify any such nonconforming Work or defects in the Project in its notice to Contractor under this Section 9.1. Contractor will have the opportunity to cure the non-conforming Work within (7) seven calendar days after receipt of the written notice issued by the City. All such curative work done shall be performed and completed to the City's satisfaction. Nothing in this Section 9.1 shall otherwise affect the City's right to exercise its rights in Section 9.2.

9.2 The City shall have the right to terminate this Agreement upon fifteen (15) days written notice for any reason. Mailing of such notice shall be equivalent to personal notice and shall be deemed to have been given at the time of receipt.

Payments made by the City pursuant to this Agreement are subject to sufficient

appropriations made by the City of Evanston City Council. In the event of termination resulting from non-appropriation or insufficient appropriation by the City Council, the City's obligations hereunder shall cease and there shall be no penalty or further payment required.

9.3 Within thirty (30) days of termination of this Agreement, the Contractor shall turn over to the City any documents, drafts, and materials, including but not limited to, outstanding work product, data, studies, test results, source documents, AutoCAD Version 2007, ArcView, PDF, Word, Excel spreadsheets, technical specifications and calculations, and any other such items specifically identified by the City related to the Work herein. Upon receipt of said items, the Contractor shall be paid for labor and expenses incurred to the date of termination as provided in Section 8.2. This Agreement is subject to termination by either party if either party is restrained by a state or federal court of competent jurisdiction from performing the provisions of this Agreement. Upon such termination, the liabilities of the parties to this Agreement shall cease, but they shall not be relieved of the duty to perform their obligations through the date of termination. No lien shall be filed by the Contractor in the event of a termination of this Agreement by the City.

9.4 If, because of death or any other occurrence, including, but not limited to, Contractor becoming insolvent, it becomes impossible for any principal or principals of the Contractor to render the services set forth in this Agreement, neither the Contractor, nor its surviving principals shall be relieved of their obligations to complete the professional services. However, in the event of such an occurrence, the City at its own option may terminate this Agreement if it is not furnished evidence that competent professional services can still be furnished as scheduled.

9.5 In the event of an emergency or threat to the life, safety or welfare of the citizens of the City, the City shall have the right to terminate this Agreement without prior written notice.

10 Insurance

10.1 The Contractor shall, at its own expense, secure and maintain in effect throughout the duration of this contract, insurance against claims for injuries to persons or damages to property which may arise from or in connection with the performance of the Work hereunder by the Contractor, its agents, representatives, employees or sub-contractors. Contractor acknowledges and agrees that if it fails to comply with all requirements of this Section 10, the City may void the Agreement.

The Contractor must give to the City Certificates of Insurance identifying the City to be an Additional Insured for all Work done pursuant to this Agreement before City staff recommends award of the contract to City Council. Any limitations or modifications on the Certificate(s) of Insurance issued to the City in compliance with this Section that conflict with the provisions of this Section 10 shall have no force and effect.

After award of the Contract to Contractor (contracts over \$500,000 in value or if the project is deemed high risk) the Contractor **shall** give the City a certified copy (ies) of the insurance policy (ies) evidencing the amounts set forth in Section 10.2, and copies of the Additional Insured endorsement to such policy (ies) which name the City as an Additional Insured for all Work done

EXHIBIT N

pursuant to this Agreement before Contractor does any Work pursuant to this Agreement. Contractor's certificate of insurance shall contain a provision that the coverage afforded under the policy(s) will not be canceled or reduced without thirty (30) days prior written notice (hand delivered or registered mail) to the City. Contractor shall promptly forward new certificate(s) of insurance evidencing the coverage(s) required herein upon annual renewal of the subject policies.

The policies and the Additional Insured endorsement must be delivered to the City within two (2) weeks of the request. All insurance policies shall be written with insurance companies licensed or authorized to do business in the State of Illinois and having a rating of not less than A-VII according to the A.M. Best Company. Should any of the insurance policies be canceled before the expiration date, the issuing company will mail thirty (30) days written notice to the City. The Contractor shall require and verify that all sub-contractors maintain insurance meeting all of the requirements stated herein.

Any deductibles or self-insured retentions must be declared to and approved by the City. At the option of the City, either the insurer shall reduce or eliminate such deductibles or self-insured retentions as respects the City, its officers, officials, employees and volunteers; or the Contractor shall provide a financial guarantee satisfactory to the City guaranteeing payment of losses and related investigations, claim administration and defense expenses.

10.2 Contractor shall carry and maintain at its own cost with such companies as are reasonably acceptable to City all necessary liability insurance (which shall include as a minimum the requirements set forth below) during the term of this Agreement, for damages caused or contributed to by Contractor, and insuring Contractor against claims which may arise out of or result from Contractor's performance or failure to perform the Services hereunder:

- a) Worker's compensation in statutory limits and employer's liability insurance in the amount of at least five hundred thousand dollars (\$500,000);
- b) Comprehensive general liability coverage which designates the City as an additional insured for not less than three million dollars (\$3,000,000) combined single limit for bodily injury, death and property damage, per occurrence;
- c) Comprehensive automobile liability insurance covering owned, non-owned, and leased vehicles for not less than one million dollars (\$1,000,000) combined single limit for bodily injury, death, or property damage, per occurrence; and

Contractor understands that the acceptance of Certificates of Insurance, policies, and any other documents by the City in no way releases the Contractor and its sub-contractors from the requirements set forth herein.

Contractor expressly agrees to waive its rights, benefits and entitlements under the "Other Insurance" clause of its commercial general liability insurance policy as respects the City. Contractor expressly agrees that its insurance coverage is required to be primary by this Agreement, that its insurance coverage shall be on a primary and non-contributory basis, and that it and its insurance carrier are estopped from denying such coverage is primary. In the event Contractor fails to purchase or procure insurance as required above, the parties expressly agree that Contractor shall be

in default under this Agreement, and that the City may recover all losses, attorney's fees and costs expended in pursuing a remedy, or reimbursement, at law or in equity, against Contractor.

11 Indemnification

11.1 The Contractor shall defend, indemnify and hold harmless the City and its officers, elected and appointed officials, agents, and employees from any and all liability, losses, or damages as a result of claims, demands, suits, actions, or proceedings of any kind or nature, including but not limited to costs, and fees, including attorney's fees, judgments or settlements, resulting from or arising out of any negligent or willful act or omission on the part of the Contractor or Contractor's sub-contractors, employees, agents or sub-contractors during the performance of this Agreement. Such indemnification shall not be limited by reason of the enumeration of any insurance coverage herein provided. This provision shall survive completion, expiration, or termination of this Agreement.

11.2 Nothing contained herein shall be construed as prohibiting the City, or its officers, agents, or employees, from defending through the selection and use of their own agents, attorneys, and experts, any claims, actions or suits brought against them. The Contractor shall be liable for the costs, fees, and expenses incurred in the defense of any such claims, actions, or suits. Nothing herein shall be construed as a limitation or waiver of defenses available to the City and employees and agents, including but not limited to the Illinois Local Governmental and Governmental Employees Tort Immunity Act, 745 ILCS 10/1-101 *et seq.*

At the City Corporation Counsel's option, Contractor must defend all suits brought upon all such Losses and must pay all costs and expenses incidental to them, but the City has the right, at its option, to participate, at its own cost, in the defense of any suit, without relieving Contractor of any of its obligations under this Agreement. Any settlement of any claim or suit related to this Project by Contractor must be made only with the prior written consent of the City Corporation Counsel, if the settlement requires any action on the part of the City.

To the extent permissible by law, Contractor waives any limits to the amount of its obligations to indemnify, defend, or contribute to any sums due under any Losses, including any claim by any employee of Contractor that may be subject to the Illinois Workers Compensation Act, 820 ILCS 305/1 *et seq.* or any other related law or judicial decision, including but not limited to, *Kotecki v. Cyclops Welding Corporation*, 146 Ill. 2d 155 (1991). The City, however, does not waive any limitations it may have on its liability under the Illinois Workers Compensation Act, the Illinois Pension Code or any other statute.

11.3 The Contractor shall be responsible for any losses and costs to repair or remedy work performed under this Agreement resulting from or arising out of any act or omission, neglect, or misconduct in the performance of its Work or its sub-contractors' work. Acceptance of the work by the City will not relieve the Contractor of the responsibility for subsequent correction of any such error, omissions and/or negligent acts or of its liability for loss or damage resulting therefrom.

11.4 All provisions of this Section 11 shall survive completion, expiration, or termination

of this Agreement.

12 Drawings and Documents

12.1 Any drawings, survey data, reports, studies, specifications, estimates, maps, plans, computations, and other documents required to be prepared by the Contractor for the Project shall be considered Works for Hire and the sole property of the City.

12.2 The Contractor and its sub-contractor shall maintain for a minimum of three (3) years after the completion of this Agreement, or for three (3) years after the termination of this Agreement, whichever comes later, adequate books, records and supporting documents to verify the amounts, recipients and uses of all disbursements of funds passing in conjunction with the Agreement. The Agreement and all books, records and supporting documents related to the Agreement shall be available for review and audit by the City and the federal funding entity, if applicable, and the Contractor agrees to cooperate fully with any audit conducted by the City and to provide full access to all materials. Failure to maintain the books, records and supporting documents required by this Subsection shall establish a presumption in favor of the City for recovery of any funds paid by the City under the Agreement for which adequate books, records, and supporting documentation are not available to support their purported disbursement.

13 Successors and Assigns

13.1 The City and the Contractor each bind themselves and their partners, successors, executors, administrators, and assigns to the other party of the Agreement and to the partners, successors, executors, administrators, and assigns of such other party in respect to all covenants of this Agreement. Neither the City nor the Contractor shall assign, sublet, or transfer its interest in this Agreement without the written consent of the other. Nothing herein shall be construed as creating any personal liability on the part of any officer or agent of any public body, which may be a party hereto, nor shall it be construed as giving any right or benefits hereunder to anyone other than the City and the Contractor.

14 Force Majeure

14.1 Whenever a period of time is provided for in this Agreement for the Contractor or the City to do or perform any act or obligation, neither party shall be liable for any delays or inability to perform if such delay is due to a cause beyond its control and without its fault or negligence including, without limitation:

- a) Acts of nature;
- b) Acts or failure to act on the part of any governmental authority other than the City or Contractor, including, but not limited to, enactment of laws, rules, regulations, codes or ordinances subsequent to the date of this Agreement;
- c) Acts of war;
- d) Acts of civil or military authority;
- e) Embargoes;
- f) Work stoppages, strikes, lockouts, or labor disputes;

- g) Public disorders, civil violence, or disobedience;
- h) Riots, blockades, sabotage, insurrection, or rebellion;
- i) Epidemics or pandemics;
- j) Terrorist acts;
- k) Fires or explosions;
- l) Nuclear accidents;
- m) Earthquakes, floods, hurricanes, tornadoes, or other similar calamities;
- n) Major environmental disturbances; or
- o) Vandalism.

If a delay is caused by any of the *force majeure* circumstances set forth above, the time period shall be extended for only the actual amount of time said party is so delayed. Further, either party claiming a delay due to an event of *force majeure* shall give the other party written notice of such event within three (3) business days of its occurrence or it shall be deemed to be waived.

15 Amendments and Modifications

15.1 Except as otherwise provided herein, the nature and scope of Work specified in this Agreement may only be modified by a written Change Order, or a written amendment to this Agreement, approved by both parties. This Agreement may be modified or amended from time to time provided, however, that no such amendment or modifications shall be effective unless reduced to writing and duly authorized and signed by the authorized representatives of the parties.

16 Standard of Care & Warranty

16.1 The Contractor shall perform all of the provisions of this Agreement to the satisfaction of the City. The City shall base its determination of the Contractor's fulfillment of the scope of the work in accordance with generally accepted professional standards applicable to the Work for this Project. The Contractor shall perform all of the provisions of this Agreement with that degree of care and skill ordinarily exercised by members of the same profession currently practicing under similar conditions.

16.2 The Contractor shall be responsible for the accuracy of its professional services under this Agreement and shall promptly make revisions or corrections resulting from its errors, omissions, or negligent acts without additional compensation. The City's acceptance of any of the Contractor's professional services shall not relieve the Contractor of its responsibility to subsequently correct any such errors or omissions. If a Contractor has provided the City with specifications for this Project which are determined to be incorrect or which require revision during the solicitation process (including but not limited to Requests for Proposals, Requests for Qualifications, or bids), the Contractor shall make such corrections or revisions to the specifications at no cost to the City. Further, upon receipt of an invoice from the City, the Contractor shall promptly reimburse the City for the reasonable costs associated with the preparation and dissemination of said corrections or revisions to appropriate parties, including but not limited to preparation of the corrected or revised documents, and printing and distribution costs.

16.3 During the pendency of its Work on this Project, the Contractor shall respond to the City's notice of any errors or omissions within twenty-four (24) hours. The Contractor shall be required to promptly visit the Project site(s) if directed to by the City.

16.4 The Contractor shall comply with all federal, state, and local statutes, regulations, rules, ordinances, judicial decisions, and administrative rulings applicable to its performance under this Agreement.

16.5 Contractor guarantees and warrants to the City that:

- a) All materials and equipment furnished under this Agreement shall be of good quality and new, unless otherwise required or permitted by the Contract Documents;
- b) The Work of this Agreement shall be free from defects which are not inherent in the quality required; and
- c) The Work shall comply with the requirements set forth in the Contract Documents.

This warranty and guarantee shall be for a period of one (1) year from the date of completion and Final Acceptance of the Work by the City, or as otherwise provided in the Contract Documents.

If, within the one year warranty period, after the Contractor has received a final payment under this Agreement, any of the Work is found to be not be in accordance with the requirements of this Agreement, or where defects in materials or workmanship may appear, or be in need of repair, the Contractor shall correct non-conforming and/or defective work or materials promptly after receipt of written notice from the City. Contractor shall immediately at its own expense repair, replace, restore, or rebuild any such Work. This remedy is in addition to any other legal or equitable remedies the City may have under this Agreement or the law.

This guarantee and warranty shall not relieve Contractor of liability for latent defects, and shall be in addition to the City's rights under the law or other guarantees or warranties, express or implied.

16.6 The provisions of this Section 16 shall survive the completion, expiration or termination of this Agreement.

17 Savings Clause

17.1 If any provision of this Agreement, or the application of such provision, shall be rendered or declared invalid by a court of competent jurisdiction, or by reason of its requiring any steps, actions, or results, the remaining parts or portions of this Agreement shall remain in full force and effect.

18 Non-Waiver of Rights

18.1 No failure or delay by the City to exercise any power given to it hereunder or to insist

upon strict compliance by Contractor with its obligations hereunder, nor any payment made by the City under this Agreement, shall constitute a waiver of the City's right to demand strict compliance with the terms hereof, unless such waiver is in writing and signed by the City.

19 Entire Agreement

19.1 This Agreement sets forth all the covenants, conditions and promises between the parties with regard to the subject matter set forth herein. There are no covenants, promises, agreements, conditions or understandings between the parties, either oral or written, other than those contained in this Agreement. This Agreement has been negotiated and entered into by each party with the opportunity to consult with its counsel regarding the terms therein. No portion of the Agreement shall be construed against a party due to the fact that one party drafted that particular portion as the rule of *contra proferentem* shall not apply.

20 Governing Law

20.1 This Agreement shall be construed in accordance with and subject to the laws and rules of the City of Evanston and the State of Illinois both as to interpretation and performance. Venue for any action arising out of or due to this Agreement shall be in Cook County, Illinois. The City shall not enter into binding arbitration to resolve any dispute related to this Agreement. The City does not waive tort immunity by entering into this Agreement.

21 Ownership of Contract Documents

21.1 Contractor is specifically prohibited from using in any form or medium, the name or logo of the City for public advertisement, unless expressly granted written permission by the City. Submission or distribution of documents to meet official regulatory requirements or for similar purposes in connection with this Project is not to be construed as publication in derogation of the City's reserved rights.

22 Notice

22.1 Any notice required to be given by this Agreement shall be deemed sufficient if made in writing and sent by certified mail, return receipt requested, or by personal service, to the persons and addresses indicated below or to such other addresses as either party hereto shall notify the other party of in writing pursuant to the provisions of this Subsection:

City of Evanston Project Manager, RFQ/RFP/Bid _____
2100 Ridge Avenue
Evanston, Illinois 60201

if to the Contractor:

22.2 Mailing of such notice as and when provided above shall be equivalent to personal notice and shall be deemed to have been given at the time of mailing.

23 Severability

23.1 Except as otherwise provided herein, the invalidity or unenforceability of any particular provision, or part thereof, of this Agreement shall not affect the other provisions, and this Agreement shall continue in all respects as if such invalid or unenforceable provision had not been contained herein.

24 Execution of Agreement

24.1 This Agreement shall be signed last by the City Manager.

25 Counterparts

25.1 For convenience, this Agreement may be executed in any number of counterparts, each of which shall be deemed to be an original.

26 Authorizations

26.1 The Contractor's authorized representatives who have executed this Agreement warrant that they have been lawfully authorized by the Contractor's board of directors or its bylaws to execute this Agreement on its behalf. The City Manager affirms that he/she has been lawfully authorized to execute this Agreement. The Contractor and the City shall deliver upon request to each other copies of all articles of incorporation, bylaws, resolutions, ordinances, or other documents which evidence their legal authority to execute this Agreement on behalf of their respective parties.

27 Time of Essence

27.1 Time is of the essence with respect to each provision hereof in which time is a factor.

IN WITNESS WHEREOF, the parties hereto have caused this Agreement to be signed by their duly authorized representatives. The effective date of this Agreement will be the date this Agreement is signed by the City Manager.

CONTRACTOR

By: _____

Name: _____

Its: _____

Date: _____

CITY OF EVANSTON

By: _____

Kelley Gandurski

Its: Interim City Manager

Date: _____

Approved as to form:

By: _____

Nicholas E. Cummings

Its: Corporation Counsel

Revision: April 2021

EXHIBIT O

BID BOND SUBMITTAL LABEL

CUT AND ATTACH LABEL ON OUTSIDE OF SEALED BID BOND SUBMITTAL

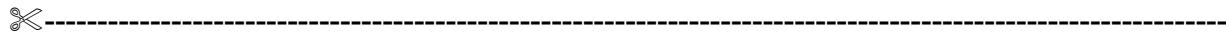

BID SUBMITTAL NUMBER: _____

BID SUBMITTAL NAME: _____

BID SUBMITTAL DUE DATE/TIME: _____

COMPANY NAME: _____

COMPANY ADDRESS: _____

COMPANY TELEPHONE #: _____



If required by the bid documents, a scanned copy of the bid bond must be included with the bid electronic submission. The City is currently not able to accept a certified check, bank cashier's check or electronic bid bond at this time.

The original bid bond (in the amount of 5% of the original bid amount) must be mailed within ten (10) days after the bid due date, to the City of Evanston Purchasing Department, 2100 Ridge Avenue - Room 4200 Evanston, Illinois 60201 Attention Purchasing Manager using the USPS (certified or priority), UPS or FedEx mail options in order to have a tracking number; which sum shall be forfeited in case the successful bidder fails to enter into a binding contract and provide a properly executed contract and surety bond within 15 days after the date the contract is awarded by the City.

EXHIBIT P

**CONTRACTOR'S STATEMENT OF COMPLIANCE
WITH FEDERAL STANDARDS**

I, _____ do hereby acknowledge that I have received a copy of the Federal Labor Standards Provisions (HUD Form 4010) and attest that my attached work proposal for work at _____ has been made in accordance with these standards. I further acknowledge that I have received General Wage Determination Number _____ with _____ modification(s) dated _____, which contains the prevailing wage rates for this area as determined by the United States Government. I attest that my contract reflects these prevailing wages for any wages I must pay to my employees for work done under this proposal. I also understand that all subcontractors who are part of my proposal are required to pay their employees the same prevailing wages, that they have been so informed by me and have adjusted their costs, if necessary, to reflect compliance with these standards.

I understand that the project under contract is being assisted with federal funds, and should I be awarded the contract, I understand that these Federal Labor Standards are applicable and shall be enforced by the City of Evanston, the enforcement agency for the Community Development Block Grant program. I understand that my failure to abide by these standards may jeopardize funding for the project and result in cancellation of any contract which was made with my firm.

Name and Address of Firm (Type or Print)

FEIN # _____
UEID# _____

BY: _____
Signature Date _____

EXHIBIT Q

**CONTRACTOR'S STATEMENT OF COMPLIANCE
WITH SECTION 3 STANDARDS**

I, _____ do hereby acknowledge that I have received a copy of the Section 3 Plan and attest that my attached work proposal for work at has been made in accordance with this Plan. I also understand that all subcontractors who are part of my proposal are required to meet the same standard, that they have been so informed by me and have made necessary adjustments to reflect compliance with the Section 3 Plan.

I understand that the project under contract is being assisted with federal funds, and should I be awarded the contract, I understand that the Section 3 Plan is applicable and shall be enforced by the City of Evanston, the enforcement agency for the Community Development Block Grant program. I understand that my failure to abide by these standards may jeopardize funding for the project and result in cancellation of any contract which was made with my firm.

As officers and representatives of _____
Name of Contractor/Sub-contractor

I, the undersigned, have read and fully agree to this Section 3 Compliance Plan, and become a party to the full implementation of this program.

Name and Address of Firm (Type or Print)

FEIN # _____
UEID# _____

BY: _____
Signature Date

Applicability

The Project or Program to which the construction work covered by this contract pertains is being assisted by the United States of America and the following Federal Labor Standards Provisions are included in this Contract pursuant to the provisions applicable to such Federal assistance.

A. 1. (i) Minimum Wages. All laborers and mechanics employed or working upon the site of the work, will be paid unconditionally and not less often than once a week, and without subsequent deduction or rebate on any account (except such payroll deductions as are permitted by regulations issued by the Secretary of Labor under the Copeland Act (29 CFR Part 3), the full amount of wages and bona fide fringe benefits (or cash equivalents thereof) due at time of payment computed at rates not less than those contained in the wage determination of the Secretary of Labor which is attached hereto and made a part hereof, regardless of any contractual relationship which may be alleged to exist between the contractor and such laborers and mechanics. Contributions made or costs reasonably anticipated for bona fide fringe benefits under Section I(b)(2) of the Davis-Bacon Act on behalf of laborers or mechanics are considered wages paid to such laborers or mechanics, subject to the provisions of 29 CFR 5.5(a)(1)(iv); also, regular contributions made or costs incurred for more than a weekly period (but not less often than quarterly) under plans, funds, or programs, which cover the particular weekly period, are deemed to be constructively made or incurred during such weekly period. Such laborers and mechanics shall be paid the appropriate wage rate and fringe benefits on the wage determination for the classification of work actually performed, without regard to skill, except as provided in 29 CFR 5.5(a)(4). Laborers or mechanics performing work in more than one classification may be compensated at the rate specified for each classification for the time actually worked therein: Provided, That the employer's payroll records accurately set forth the time spent in each classification in which work is performed. The wage determination (including any additional classification and wage rates conformed under 29 CFR 5.5(a)(1)(ii) and the Davis-Bacon poster (WH-1321) shall be posted at all times by the contractor and its subcontractors at the site of the work in a prominent and accessible, place where it can be easily seen by the workers.

(ii) (a) Any class of laborers or mechanics which is not listed in the wage determination and which is to be employed under the contract shall be classified in conformance with the wage determination. HUD shall approve an additional classification and wage rate and fringe benefits therefor only when the following criteria have been met:

(1) The work to be performed by the classification requested is not performed by a classification in the wage determination; and

(2) The classification is utilized in the area by the construction industry; and

(3) The proposed wage rate, including any bona fide fringe benefits, bears a reasonable relationship to the wage rates contained in the wage determination.

(b) If the contractor and the laborers and mechanics to be employed in the classification (if known), or their representatives, and HUD or its designee agree on the classification and wage rate (including the amount designated for fringe benefits where appropriate), a report of the action taken shall be sent by HUD or its designee to the Administrator of the Wage and Hour Division, Employment Standards Administration, U.S. Department of Labor, Washington, D.C. 20210. The Administrator, or an authorized representative, will approve, modify, or disapprove every additional classification action within 30 days of receipt and so advise HUD or its designee or will notify HUD or its designee within the 30-day period that additional time is necessary. (Approved by the Office of Management and Budget under OMB control number 1215-0140.)

(c) In the event the contractor, the laborers or mechanics to be employed in the classification or their representatives, and HUD or its designee do not agree on the proposed classification and wage rate (including the amount designated for fringe benefits, where appropriate), HUD or its designee shall refer the questions, including the views of all interested parties and the recommendation of HUD or its designee, to the Administrator for determination. The Administrator, or an authorized representative, will issue a determination within 30 days of receipt and so advise HUD or its designee or will notify HUD or its designee within the 30-day period that additional time is necessary. (Approved by the Office of Management and Budget under OMB Control Number 1215-0140.)

(d) The wage rate (including fringe benefits where appropriate) determined pursuant to subparagraphs (1)(ii)(b) or (c) of this paragraph, shall be paid to all workers performing work in the classification under this contract from the first day on which work is performed in the classification.

(iii) Whenever the minimum wage rate prescribed in the contract for a class of laborers or mechanics includes a fringe benefit which is not expressed as an hourly rate, the contractor shall either pay the benefit as stated in the wage determination or shall pay another bona fide fringe benefit or an hourly cash equivalent thereof.

(iv) If the contractor does not make payments to a trustee or other third person, the contractor may consider as part

of the wages of any laborer or mechanic the amount of any costs reasonably anticipated in providing bona fide fringe benefits under a plan or program, Provided, That the Secretary of Labor has found, upon the written request of the contractor, that the applicable standards of the Davis-Bacon Act have been met. The Secretary of Labor may require the contractor to set aside in a separate account assets for the meeting of obligations under the plan or program. (Approved by the Office of Management and Budget under OMB Control Number 1215-0140.)

2. Withholding. HUD or its designee shall upon its own action or upon written request of an authorized representative of the Department of Labor withhold or cause to be withheld from the contractor under this contract or any other Federal contract with the same prime contractor, or any other Federally-assisted contract subject to Davis-Bacon prevailing wage requirements, which is held by the same prime contractor so much of the accrued payments or advances as may be considered necessary to pay laborers and mechanics, including apprentices, trainees and helpers, employed by the contractor or any subcontractor the full amount of wages required by the contract. In the event of failure to pay any laborer or mechanic, including any apprentice, trainee or helper, employed or working on the site of the work, all or part of the wages required by the contract, HUD or its designee may, after written notice to the contractor, sponsor, applicant, or owner, take such action as may be necessary to cause the suspension of any further payment, advance, or guarantee of funds until such violations have ceased. HUD or its designee may, after written notice to the contractor, disburse such amounts withheld for and on account of the contractor or subcontractor to the respective employees to whom they are due. The Comptroller General shall make such disbursements in the case of direct Davis-Bacon Act contracts.

3. (i) Payrolls and basic records. Payrolls and basic records relating thereto shall be maintained by the contractor during the course of the work preserved for a period of three years thereafter for all laborers and mechanics working at the site of the work. Such records shall contain the name, address, and social security number of each such worker, his or her correct classification, hourly rates of wages paid (including rates of contributions or costs anticipated for bona fide fringe benefits or cash equivalents thereof of the types described in Section 1(b)(2)(B) of the Davis-bacon Act), daily and weekly number of hours worked, deductions made and actual wages paid. Whenever the Secretary of Labor has found under 29 CFR 5.5 (a)(1)(iv) that the wages of any laborer or mechanic include the amount of any costs reasonably anticipated in providing benefits under a plan or program described in Section 1(b)(2)(B) of the Davis-Bacon Act, the contractor shall maintain records which show that the commitment to provide such benefits is enforceable, that the plan or program is financially responsible, and that the plan or program has been

communicated in writing to the laborers or mechanics affected, and records which show the costs anticipated or the actual cost incurred in providing such benefits. Contractors employing apprentices or trainees under approved programs shall maintain written evidence of the registration of apprenticeship programs and certification of trainee programs, the registration of the apprentices and trainees, and the ratios and wage rates prescribed in the applicable programs. (Approved by the Office of Management and Budget under OMB Control Numbers 1215-0140 and 1215-0017.)

(ii) (a) The contractor shall submit weekly for each week in which any contract work is performed a copy of all payrolls to HUD or its designee if the agency is a party to the contract, but if the agency is not such a party, the contractor will submit the payrolls to the applicant sponsor, or owner, as the case may be, for transmission to HUD or its designee. The payrolls submitted shall set out accurately and completely all of the information required to be maintained under 29 CFR 5.5(a)(3)(i) except that full social security numbers and home addresses shall not be included on weekly transmittals. Instead the payrolls shall only need to include an individually identifying number for each employee (e.g., the last four digits of the employee's social security number). The required weekly payroll information may be submitted in any form desired. Optional Form WH-347 is available for this purpose from the Wage and Hour Division Web site at <http://www.dol.gov/esa/whd/forms/wh347instr.htm> or its successor site. The prime contractor is responsible for the submission of copies of payrolls by all subcontractors. Contractors and subcontractors shall maintain the full social security number and current address of each covered worker, and shall provide them upon request to HUD or its designee if the agency is a party to the contract, but if the agency is not such a party, the contractor will submit the payrolls to the applicant sponsor, or owner, as the case may be, for transmission to HUD or its designee, the contractor, or the Wage and Hour Division of the Department of Labor for purposes of an investigation or audit of compliance with prevailing wage requirements. It is not a violation of this subparagraph for a prime contractor to require a subcontractor to provide addresses and social security numbers to the prime contractor for its own records, without weekly submission to HUD or its designee. (Approved by the Office of Management and Budget under OMB Control Number 1215-0149.)

(b) Each payroll submitted shall be accompanied by a "Statement of Compliance," signed by the contractor or subcontractor or his or her agent who pays or supervises the payment of the persons employed under the contract and shall certify the following:

(1) That the payroll for the payroll period contains the information required to be provided under 29 CFR 5.5 (a)(3)(ii), the appropriate information is being maintained under 29 CFR 5.5(a)(3)(i), and that such information is correct and complete;

(2) That each laborer or mechanic (including each helper, apprentice, and trainee) employed on the contract during the payroll period has been paid the full weekly wages earned, without rebate, either directly or indirectly, and that no deductions have been made either directly or indirectly from the full wages earned, other than permissible deductions as set forth in 29 CFR Part 3;

(3) That each laborer or mechanic has been paid not less than the applicable wage rates and fringe benefits or cash equivalents for the classification of work performed, as specified in the applicable wage determination incorporated into the contract.

(c) The weekly submission of a properly executed certification set forth on the reverse side of Optional Form WH-347 shall satisfy the requirement for submission of the "Statement of Compliance" required by subparagraph A.3.(ii)(b).

(d) The falsification of any of the above certifications may subject the contractor or subcontractor to civil or criminal prosecution under Section 1001 of Title 18 and Section 231 of Title 31 of the United States Code.

(iii) The contractor or subcontractor shall make the records required under subparagraph A.3.(i) available for inspection, copying, or transcription by authorized representatives of HUD or its designee or the Department of Labor, and shall permit such representatives to interview employees during working hours on the job. If the contractor or subcontractor fails to submit the required records or to make them available, HUD or its designee may, after written notice to the contractor, sponsor, applicant or owner, take such action as may be necessary to cause the suspension of any further payment, advance, or guarantee of funds. Furthermore, failure to submit the required records upon request or to make such records available may be grounds for debarment action pursuant to 29 CFR 5.12.

4. Apprentices and Trainees.

(i) **Apprentices.** Apprentices will be permitted to work at less than the predetermined rate for the work they performed when they are employed pursuant to and individually registered in a bona fide apprenticeship program registered with the U.S. Department of Labor, Employment and Training Administration, Office of Apprenticeship Training, Employer and Labor Services, or with a State Apprenticeship Agency recognized by the Office, or if a person is employed in his or her first 90 days of probationary employment as an apprentice in such an apprenticeship program, who is not individually registered in the program, but who has been certified by the Office of Apprenticeship Training, Employer and Labor Services or a State Apprenticeship Agency (where appropriate) to be eligible for probationary employment as an apprentice. The allowable ratio of apprentices to journeymen on the job site in any craft classification shall not be greater than the ratio permitted to the contractor as to the entire work force under the registered program. Any worker listed on a payroll at an apprentice wage rate, who

is not registered or otherwise employed as stated above, shall be paid not less than the applicable wage rate on the wage determination for the classification of work actually performed. In addition, any apprentice performing work on the job site in excess of the ratio permitted under the registered program shall be paid not less than the applicable wage rate on the wage determination for the work actually performed. Where a contractor is performing construction on a project in a locality other than that in which its program is registered, the ratios and wage rates (expressed in percentages of the journeyman's hourly rate) specified in the contractor's or subcontractor's registered program shall be observed. Every apprentice must be paid at not less than the rate specified in the registered program for the apprentice's level of progress, expressed as a percentage of the journeymen hourly rate specified in the applicable wage determination. Apprentices shall be paid fringe benefits in accordance with the provisions of the apprenticeship program. If the apprenticeship program does not specify fringe benefits, apprentices must be paid the full amount of fringe benefits listed on the wage determination for the applicable classification. If the Administrator determines that a different practice prevails for the applicable apprentice classification, fringes shall be paid in accordance with that determination. In the event the Office of Apprenticeship Training, Employer and Labor Services, or a State Apprenticeship Agency recognized by the Office, withdraws approval of an apprenticeship program, the contractor will no longer be permitted to utilize apprentices at less than the applicable predetermined rate for the work performed until an acceptable program is approved.

(ii) **Trainees.** Except as provided in 29 CFR 5.16, trainees will not be permitted to work at less than the predetermined rate for the work performed unless they are employed pursuant to and individually registered in a program which has received prior approval, evidenced by formal certification by the U.S. Department of Labor, Employment and Training Administration. The ratio of trainees to journeymen on the job site shall not be greater than permitted under the plan approved by the Employment and Training Administration. Every trainee must be paid at not less than the rate specified in the approved program for the trainee's level of progress, expressed as a percentage of the journeyman hourly rate specified in the applicable wage determination. Trainees shall be paid fringe benefits in accordance with the provisions of the trainee program. If the trainee program does not mention fringe benefits, trainees shall be paid the full amount of fringe benefits listed on the wage determination unless the Administrator of the Wage and Hour Division determines that there is an apprenticeship program associated with the corresponding journeyman wage rate on the wage determination which provides for less than full fringe benefits for apprentices. Any employee listed on the payroll at a trainee rate who is not registered and participating in a training plan approved by

the Employment and Training Administration shall be paid not less than the applicable wage rate on the wage determination for the work actually performed. In addition, any trainee performing work on the job site in excess of the ratio permitted under the registered program shall be paid not less than the applicable wage rate on the wage determination for the work actually performed. In the event the Employment and Training Administration withdraws approval of a training program, the contractor will no longer be permitted to utilize trainees at less than the applicable predetermined rate for the work performed until an acceptable program is approved.

(iii) Equal employment opportunity. The utilization of apprentices, trainees and journeymen under 29 CFR Part 5 shall be in conformity with the equal employment opportunity requirements of Executive Order 11246, as amended, and 29 CFR Part 30.

5. Compliance with Copeland Act requirements. The contractor shall comply with the requirements of 29 CFR Part 3 which are incorporated by reference in this contract

6. Subcontracts. The contractor or subcontractor will insert in any subcontracts the clauses contained in subparagraphs 1 through 11 in this paragraph A and such other clauses as HUD or its designee may by appropriate instructions require, and a copy of the applicable prevailing wage decision, and also a clause requiring the subcontractors to include these clauses in any lower tier subcontracts. The prime contractor shall be responsible for the compliance by any subcontractor or lower tier subcontractor with all the contract clauses in this paragraph.

7. Contract termination; debarment. A breach of the contract clauses in 29 CFR 5.5 may be grounds for termination of the contract and for debarment as a contractor and a subcontractor as provided in 29 CFR 5.12.

8. Compliance with Davis-Bacon and Related Act Requirements. All rulings and interpretations of the Davis-Bacon and Related Acts contained in 29 CFR Parts 1, 3, and 5 are herein incorporated by reference in this contract

9. Disputes concerning labor standards. Disputes arising out of the labor standards provisions of this contract shall not be subject to the general disputes clause of this contract. Such disputes shall be resolved in accordance with the procedures of the Department of Labor set forth in 29 CFR Parts 5, 6, and 7. Disputes within the meaning of this clause include disputes between the contractor (or any of its subcontractors) and HUD or its designee, the U.S. Department of Labor, or the employees or their representatives.

10. (i) Certification of Eligibility. By entering into this contract the contractor certifies that neither it (nor he or she) nor any person or firm who has an interest in the contractor's firm is a person or firm ineligible to be awarded Government contracts by virtue of Section 3(a) of the Davis-Bacon Act or 29 CFR 5.12(a)(1) or to be

awarded HUD contracts or participate in HUD programs pursuant to 24 CFR Part 24.

(ii) No part of this contract shall be subcontracted to any person or firm ineligible for award of a Government contract by virtue of Section 3(a) of the Davis-Bacon Act or 29 CFR 5.12(a)(1) or to be awarded HUD contracts or participate in HUD programs pursuant to 24 CFR Part 24.

(iii) The penalty for making false statements is prescribed in the U.S. Criminal Code, 18 U.S.C. 1001. Additionally, U.S. Criminal Code, Section 1 01 0, Title 18, U.S.C., "Federal Housing Administration transactions", provides in part: "Whoever, for the purpose of . . . influencing in any way the action of such Administration..... makes, utters or publishes any statement knowing the same to be false..... shall be fined not more than \$5,000 or imprisoned not more than two years, or both."

11. Complaints, Proceedings, or Testimony by Employees. No laborer or mechanic to whom the wage, salary, or other labor standards provisions of this Contract are applicable shall be discharged or in any other manner discriminated against by the Contractor or any subcontractor because such employee has filed any complaint or instituted or caused to be instituted any proceeding or has testified or is about to testify in any proceeding under or relating to the labor standards applicable under this Contract to his employer.

B. Contract Work Hours and Safety Standards Act. The provisions of this paragraph B are applicable where the amount of the prime contract exceeds \$100,000. As used in this paragraph, the terms "laborers" and "mechanics" include watchmen and guards.

(1) Overtime requirements. No contractor or subcontractor contracting for any part of the contract work which may require or involve the employment of laborers or mechanics shall require or permit any such laborer or mechanic in any workweek in which the individual is employed on such work to work in excess of 40 hours in such workweek unless such laborer or mechanic receives compensation at a rate not less than one and one-half times the basic rate of pay for all hours worked in excess of 40 hours in such workweek.

(2) Violation; liability for unpaid wages; liquidated damages. In the event of any violation of the clause set forth in subparagraph (1) of this paragraph, the contractor and any subcontractor responsible therefor shall be liable for the unpaid wages. In addition, such contractor and subcontractor shall be liable to the United States (in the case of work done under contract for the District of Columbia or a territory, to such District or to such territory), for liquidated damages. Such liquidated damages shall be computed with respect to each individual laborer or mechanic, including watchmen and guards, employed in violation of the clause set forth in subparagraph (1) of this paragraph, in the sum of \$10 for each calendar day on which such individual was required or permitted to work in excess of the standard workweek of 40 hours without payment of the overtime wages required by the clause set forth in subparagraph (1) of this paragraph.

(3) Withholding for unpaid wages and liquidated damages. HUD or its designee shall upon its own action or upon written request of an authorized representative of the Department of Labor withhold or cause to be withheld, from any moneys payable on account of work performed by the contractor or subcontractor under any such contract or any other Federal contract with the same prime contract, or any other Federally-assisted contract subject to the Contract Work Hours and Safety Standards Act which is held by the same prime contractor such sums as may be determined to be necessary to satisfy any liabilities of such contractor or subcontractor for unpaid wages and liquidated damages as provided in the clause set forth in subparagraph (2) of this paragraph.

(4) Subcontracts. The contractor or subcontractor shall insert in any subcontracts the clauses set forth in subparagraph (1) through (4) of this paragraph and also a clause requiring the subcontractors to include these clauses in any lower tier subcontracts. The prime contractor shall be responsible for compliance by any subcontractor or lower tier subcontractor with the clauses set forth in subparagraphs (1) through (4) of this paragraph.

C. Health and Safety. The provisions of this paragraph C are applicable where the amount of the prime contract exceeds \$100,000.

(1) No laborer or mechanic shall be required to work in surroundings or under working conditions which are unsanitary, hazardous, or dangerous to his health and safety as determined under construction safety and health standards promulgated by the Secretary of Labor by regulation.

(2) The Contractor shall comply with all regulations issued by the Secretary of Labor pursuant to Title 29 Part 1926 and failure to comply may result in imposition of sanctions pursuant to the Contract Work Hours and Safety Standards Act, (Public Law 91-54, 83 Stat 96). 40 USC 3701 et seq.

(3) The contractor shall include the provisions of this paragraph in every subcontract so that such provisions will be binding on each subcontractor. The contractor shall take such action with respect to any subcontractor as the Secretary of Housing and Urban Development or the Secretary of Labor shall direct as a means of enforcing such provisions.

"General Decision Number: IL20220009 02/25/2022

Superseded General Decision Number: IL20210009

State: Illinois

Construction Types: Building, Heavy, Highway and Residential

County: Cook County in Illinois.

BUILDING, RESIDENTIAL, HEAVY, AND HIGHWAY PROJECTS (does not include landscape projects).

Note: Contracts subject to the Davis-Bacon Act are generally required to pay at least the applicable minimum wage rate required under Executive Order 14026 or Executive Order 13658. Please note that these Executive Orders apply to covered contracts entered into by the federal government that are subject to the Davis-Bacon Act itself, but do not apply to contracts subject only to the Davis-Bacon Related Acts, including those set forth at 29 CFR 5.1(a)(2)-(60).

<p>If the contract is entered into on or after January 30, 2022, or the contract is renewed or extended (e.g., an option is exercised) on or after January 30, 2022:</p>	<ul style="list-style-type: none"> . Executive Order 14026 generally applies to the contract. . The contractor must pay all covered workers at least \$15.00 per hour (or the applicable wage rate listed on this wage determination, if it is higher) for all hours spent performing on the contract in 2022.
<p>If the contract was awarded on or between January 1, 2015 and January 29, 2022, and the contract is not renewed or extended on or after January 30, 2022:</p>	<ul style="list-style-type: none"> . Executive Order 13658 generally applies to the contract. . The contractor must pay all covered workers at least \$11.25 per hour (or the applicable wage rate listed on this wage determination, if it is higher) for all hours spent performing on

	that contract in 2022.
--	------------------------

The applicable Executive Order minimum wage rate will be adjusted annually. If this contract is covered by one of the Executive Orders and a classification considered necessary for performance of work on the contract does not appear on this wage determination, the contractor must still submit a conformance request.

Additional information on contractor requirements and worker protections under the Executive Orders is available at <https://www.dol.gov/agencies/whd/government-contracts>.

Modification Number	Publication Date
0	01/07/2022
1	01/14/2022
2	02/25/2022

ASBE0017-001 06/01/2021

	Rates	Fringes
ASBESTOS WORKER/INSULATOR		
Includes the application of all insulating materials, protective coverings, coatings, and finishes to all types of mechanical systems.....	\$ 51.80	30.60
Fire Stop Technician.....	\$ 41.44	27.85
HAZARDOUS MATERIAL HANDLER		
includes preparation, wetting, stripping removal scrapping, vacuuming, bagging and disposal of all insulation materials, whether they contain asbestos or not, from mechanical systems.....	\$ 38.85	27.85

 BOIL0001-001 05/01/2021

	Rates	Fringes
BOILERMAKER.....	\$ 52.61	33.07

BRIL0021-001 06/01/2016

	Rates	Fringes
BRICKLAYER.....	\$ 44.88	26.62

BRIL0021-004 06/01/2017

	Rates	Fringes
Marble Mason.....	\$ 44.63	26.83

BRIL0021-006 06/01/2017

	Rates	Fringes
TERRAZZO WORKER/SETTER.....	\$ 44.38	25.84
TILE FINISHER.....	\$ 38.56	22.10
TILE SETTER.....	\$ 45.49	25.72

BRIL0021-009 06/01/2017

	Rates	Fringes
MARBLE FINISHER.....	\$ 33.95	26.03

BRIL0021-012 06/01/2017

	Rates	Fringes
Pointer, cleaner and caulker.....	\$ 45.42	24.06

CARP0555-001 06/01/2021

BUILDING, HEAVY, AND HIGHWAY

	Rates	Fringes
CARPENTER		
Carpenter, Lather, Millwright, Piledriver, and Soft Floor Layer		
Building.....	\$ 50.86	37.34
Heavy & Highway.....	\$ 50.86	37.34

CARP0555-002 10/01/2021

RESIDENTIAL CONSTRUCTION

	Rates	Fringes
CARPENTER.....	\$ 42.61	33.67

 ELEC0009-003 05/30/2021

	Rates	Fringes
Line Construction		
Groundman.....	\$ 44.11	62.32%
Lineman and Equipment		
Operator.....	\$ 56.55	62.32%

 ELEC0134-001 06/07/2021

	Rates	Fringes
ELECTRICIAN.....	\$ 51.00	37.39

 ELEC0134-003 06/07/2021

	Rates	Fringes
ELECTRICIAN		
ELECTRICAL TECHNICIAN.....	\$ 46.26	28.23

The work shall consist of the installation, operation, inspection, maintenance, repair and service of radio, television, recording, voice sound vision production and reproduction, telephone and telephone interconnect, facsimile, data apparatus, coaxial, fibre optic and wireless equipment, appliances and systems used for the transmission and reception of signals of any nature, business, domestic, commercial, education, entertainment and residential purposes, including but not limited to communication and telephone, electronic and sound equipment, fibre optic and data communication systems, and the performance of any task directly related to such installation or service whether at new or existing sites, such tasks to include the placing of wire and cable and electrical power conduit or other raceway work within the equipment room and pulling wire and/or cable through conduit and the installation of any incidental conduit.

ELEV0002-001 01/01/2022

	Rates	Fringes
ELEVATOR MECHANIC.....	\$ 62.47	36.885+a+b

FOOTNOTES:

a) PAID HOLIDAYS: New Year's Day; Memorial Day; Independence Day; Labor Day; Thanksgiving Day; Day after Thanksgiving Day; Veterans' Day and Christmas Day.

b) Employer contributes 8% of regular hourly rate as vacation pay credit for employee with more than 5 years of service, and 6% for employee with less than 5 years service

* ENGI0150-006 06/01/2021

Building and Residential Construction

	Rates	Fringes
OPERATOR: Power Equipment		
GROUP 1.....	\$ 53.60	44.40
GROUP 2.....	\$ 52.30	44.40
GROUP 3.....	\$ 49.75	44.40
GROUP 4.....	\$ 48.00	44.40

POWER EQUIPMENT OPERATORS CLASSIFICATIONS

GROUP 1: Mechanic; Asphalt Plant*; Asphalt Spreader; Autograde*; Backhoes with Caisson attachment*:Batch Plant*; Benoto(Requires two Engineers); Boiler and Throttle Valve; Caisson Rigs*; Central Redi-Mix Plant*; Combination Backhoe Front Endloader Machine; Compressor and Throttle Valve; Concrete Breaker (Truck Mounted)*; Concrete Conveyor; Concrete Conveyor, Truck Mounted; Concrete Paver over 27E cu. ft.*; Concrete Paver 27E cu ft and Under*; Concrete Placer*; Concrete Placing Boom; Concrete Pump (Truck Mounted); Concrete Tower; Cranes*; Cranes, Hammerhead*; Cranes, (GCI and similar type Requires two operators only); Creter Crane; Crusher, Stone, etc; Derricks; Derricks, Traveling*; Formless Curb and Gutter Machine*; Grader, Elevating; Grouting Machines; Highlift Shovels or Front Endloader 2 1/4 yd. and over; Hoists, Elevators, Outside

Type Rack and pinion and similar Machines; Hoists, One, Two, and Three Drum; Hoists, Two Tugger One Floor; Hydraulic Backhoes*; Hydraulic Boom Trucks; Hydraulic Vac (and similar equipment); Locomotives; Motor Patrol*; Pile Drivers and Skid Rig*; Post Hole Digger; Pre-Stress Machine; Pump Cretes Dual Ram (Requiring frequent Lubrication and Water); Pump Cretes; Squeeze Cretes-Screw Type Pumps Gypsum Bulker and Pump; Raised and Blind Hole Drill*; Roto Mill Grinder (36" and Over)*; Roto Mill Grinder (Less Than 36")*; Scoops-Tractor Drawn; Slip-Form Paver*; Straddle Buggies; Tournapull; Tractor with Boom, and Side Boom; and Trenching Machines*.

GROUP 2: Bobcat (over 3/4 cu yd); Boilers; Broom, Power Propelled; Bulldozers; Concrete Mixer (Two Bag and over); Conveyor, Portable; Forklift Trucks; Greaser Engineer; Highlift Shovels or Front End loaders under 2 1/4 cu yd; Automatic Hoists, Hoists, Inside Elevators; Hoists, Sewer Dragging Machine; Hoists, Tugger Single Drum; Laser Screed; Rock Drill (Self-Propelled); Rock Drill (Truck Mounted)*; Rollers; Steam Generators; Tractors; Tractor Drawn Vibratory Roller (Receives an additional \$.50 per hour); Winch Trucks with "A" Frame.

GROUP 3: Air Compressor-Small 250 and Under (1 to 5 not to exceed a total of 300 ft); Air Compressor-Large over 250; Combination-Small Equipment Operator; Generator- Small 50 kw and under; Generator-Large over 50 kw; Heaters, Mechanical; Hoists, Inside Elevators (Remodeling or Renovatin work); Hydrualic Power Units (Pile Driving, Extracting, and Drilling); Low Boys; Pumps Over 3" (1 To 3 not to exceed a total of 300 ft); Pumps, Well Points; Welding Machines (2 through 5); Winches, 4 Small Electric Drill Winches; Bobcat (up to and including 3/4 cu yd)

GROUP 4 - Bobcats and/or other Skid Steer Loaders; Brick Forklifts; Oilers

*-Requires Oiler

* ENGI0150-025 06/01/2021

Heavy and Highway Construction

Rates

Fringes

OPERATOR: Power Equipment

GROUP 1.....	\$ 51.80	44.40
GROUP 2.....	\$ 51.25	44.40
GROUP 3.....	\$ 49.20	44.40
GROUP 4.....	\$ 47.80	44.40
GROUP 5.....	\$ 46.60	44.40

POWER EQUIPMENT OPERATOR CLASSIFICATIONS

GROUP 1: Asphalt Plant*; Asphalt Heater and Planer combination; Asphalt Heater Scarfire*, Asphalt Spreader; Autograder/ GOMACO or similar; ABG Paver*, Backhoes with Caisson attachment*, Ballast Regulator, Belt Loader*; Caisson Rigs*Car Dumper, Central Redi-Mix Plant*, Combination Backhoe; Front End Loader Machine (1 cu yd or over Backhoe bucket or with attachments); Concrete Breaker (truck mounted); Concrete Conveyor; Concrete Paver over 27E cu ft*; Concrete Placer*; Concrete Tube Float; Cranes, all attachments*; Cranes, Hammerhead, Linden, Peco and machines of a like nature*; Creter Crane; Crusher, stone; All Derricks; Derrick Boats; Derricks, traveling*; Dowell Machine with Air Compressor (\$1.00 above Class 1); Dredges*; Field Mechanic Welder; Formless Curb and Gutter Machine*; Gradall and machines of a like nature*; Grader, Elevating; Grader, Motor Grader, Motor Patrol, Auto Patrol, Form Grader, Pull Grader, Subgrader; Guard Rail Post Driver mounted*; Hoists, one, two, and three Drum; Hydraulic Backhoes*; Backhoes with Shear attachments*; Mucking Machine; Pile Drivers and Skid Rig*; Pre-Stress Machine; Pump Cretes Dual Ram (requires frequent lubrication and water)*; Rock Drill- Crawler or Skid Rig*; Rock Drill truck mounted*; Rock/ Track Tamper; Roto Mill Grinder, (36" and over)*; Slip-Form Paver*; Soil Test Drill Rig, truck mounted*; Straddle Buggies; Hydraulic Telescoping Form (tunnel); Tractor Drawn Belt Loader*; Tractor Drawn Belt Loader with attached Pusher (two engineers); Tractor with boom; Tractaire with attachment; Traffic Barrier Transfer Machine*; Trenching Machine; Truck Mounted Concrete Pump with boom*; Underground Boring and/or Mining Machines 5 ft in diameter and over tunnel, etc.*; Wheel Excavator* & Widener (Apsco); Raised or Blind Hoe Drill, Tunnel & Shaft*

GROUP 2: Batch Plant*; Bituminous Mixer; Boiler and Throttle Valve; Bulldozer; Car Loader Trailing Conveyors; Combination Backhoe Front End Loader Machine, (less than 1 cu yd Backhoe Bucket with attachments); Compressor and Throttle Valve; Compressor, common receiver (3); Concrete

Breaker or Hydro Hammer; Concrete Grinding Machine; Concrete Mixer or Paver 7S series to and including 27 cu ft; Concrete Spreader; Concrete Curing Machine; Burlap Machine; Belting Machine and Sealing Machine; Concrete Wheel Saw; Conveyor Muck Cars (Haglund or similar type); Drills (all); Finishing Machine-Concrete; Greaser Engineer; Highlift Shovels or Front End Loader; Hoist- Sewer Dragging Machine; Hydraulic Boom Trucks, all attachments; Hydro-Blaster (requires two operators); Laser Screed*; Locomotives, Dinky; Off-Road Hauling Units (including articulating); Pump Cretes; Squeeze Cretes-Screw Type pumps, Gypsum Bulker and Pump; Roller Asphalt; Rotary Snow Plows; Rototiller, Seaman, self-Propelled; Scoops-Tractor Drawn; Self-propelled Compactor; Spreader-Chip-Stone; Scraper; Scraper-Prime Mover in Tandem regardless of size (add \$1.00 to Group 2 hourly rate for each hour and for each machine attached thereto add \$1.00 to Group 2 hourly rate for each hour); Tank Car Heater; Tractors, Push, pulling Sheeps Foot, Disc, or Compactor, etc; Tug Boats

GROUP 3: Boilers; Brooms, all power propelled; Cement Supply Tender; Compressor, Common Receiver (2); Concrete Mixer, two bag and over; Conveyor, Portable; Farm type Tractors used for mowing, seeding, etc; Fireman on Boilers; Forklift Trucks; Grouting Machines; Hoists, Automatic; Hoists, all Elevators; Hoists, Tugger single Drum; Jeep Diggers; Low Boys; Pipe Jacking Machines; Post-hole Digger; Power Saw, Concrete, Power Driven; Pug Mills; Rollers, other than asphalt; Seed and Straw Blower; Steam Generators; Stump Machine; Winch Trucks with A-Frame; Work Boats; Tamper-Form motor driven

GROUP 4: Air compressor - Small 250 and under (1 to 5 not to exceed a total of 300 ft); Air Compressor - Large over 250; Combination - Small Equipment Operator; Directional Boring Machine; Generators - Small 50 kw and under; Generators - Large , over 50 kw; Heaters, Mechanical; Hydraulic power unit (Pile Driving, Extracting or Drilling); Light Plants (1 to 5); Pumps, over 3" (1 to 3, not to exceed a total of 300 ft); Pumps, Well Points; Tractaire; Welding Machines (2 through 5); Winches, 4 small electric drill winches;

GROUP 5: Bobcats (All); Brick Forklifts; Oilers; Directional Boring

*Requires Oiler

 IRON0001-026 06/01/2021

	Rates	Fringes
IRONWORKER		
Sheeter.....	\$ 54.76	41.45
Structural and Reinforcing..	\$ 54.51	41.45

 IRON0063-001 06/01/2021

	Rates	Fringes
IRONWORKER, ORNAMENTAL.....	\$ 52.13	39.47

 IRON0063-002 06/01/2020

	Rates	Fringes
IRONWORKER		
Fence Erector.....	\$ 44.42	29.73

 IRON0136-001 07/01/2021

	Rates	Fringes
IRONWORKER		
Machinery Movers; Riggers;		
Macinery Erectors.....	\$ 45.00	39.39
Master Riggers.....	\$ 47.50	39.39

 LAB00002-006 06/01/2018

	Rates	Fringes
LABORER (BUILDING & RESIDENTIAL)		
GROUP 1.....	\$ 42.72	28.19
GROUP 2.....	\$ 42.72	28.19
GROUP 3.....	\$ 42.80	28.19
GROUP 4.....	\$ 42.82	28.19
GROUP 5.....	\$ 42.87	28.19
GROUP 6.....	\$ 42.92	28.19
GROUP 7.....	\$ 42.95	28.19
GROUP 8.....	\$ 43.05	28.19
GROUP 9.....	\$ 43.07	28.19
GROUP 10.....	\$ 43.17	28.19

GROUP 11.....	\$ 43.00	28.19
GROUP 12.....	\$ 43.72	28.19

LABORER CLASSIFICATIONS

GROUP 1: Building Laborers; Plasterer Tenders; Pumps for Dewatering; and other unclassified laborers.

GROUP 2: Fireproofing and Fire Shop laborers.

GROUP 3: Cement Gun.

GROUP 4: Chimney over 40 ft.; Scaffold Laborers.

GROUP 5: Cement Gun Nozzle Laborers (Gunite); Windlass and capstan person.

GROUP 6: Stone Derrickmen & Handlers.

GROUP 7: Jackhammermen; Power driven concrete saws; and other power tools.

GROUP 8: Firebrick & Boiler Laborers.

GROUP 9: Chimney on fire brick; Caisson diggers; & Well Point System men.

GROUP 10: Boiler Setter Plastic Laborers.

GROUP 11: Jackhammermen on fire brick work only.

GROUP 12: Dosimeter use (any device) monitoring nuclear exposure); Asbestos Abatement Laborer; Toxic and Hazardous Waste Removal Laborers.

LAB00002-007 06/01/2018

	Rates	Fringes
LABORER (HEAVY & HIGHWAY)		
GROUP 1.....	\$ 42.72	28.19
GROUP 2.....	\$ 42.80	28.19
GROUP 3.....	\$ 42.87	28.19
GROUP 4.....	\$ 43.00	28.19
GROUP 5.....	\$ 42.72	28.19

LABORER CLASSIFICATIONS

GROUP 1: Common laborer; Tenders; Material expeditor (asphalt plant); Street paving, Grade separation, sidewalk, curb & gutter, strippers & All laborers not otherwise mentioned

GROUP 2: Asphalt tampers & smoothers; Cement gun laborers

GROUP 3: Cement Gun Nozzle (laborers), Gunite

GROUP 4: Rakers, Lutemen; Machine-Screwmen; Kettlemen; Mixermen; Drun-men; Jackhammermen (asphalt); Paintmen; Mitre box spreaders; Laborers on birch, overman and similar spreader equipment; Laborers on APSCO; Laborers on air compressor; Paving Form Setter; Jackhammermen (concrete); Power drive concrete saws; other power tools.

GROUP 5: Asbestos Abatement Laborers; Toxic and Hazardous Waste Removal Laborers, Dosimeter (any device) monitoring nuclear exposure

LAB00002-008 06/01/2018

	Rates	Fringes
LABORER (Compressed Air)		
0 - 15 POUNDS.....	\$ 43.72	28.19
16 - 20 POUNDS.....	\$ 44.22	28.19
21 - 26 POUNDS.....	\$ 44.72	28.19
27 - 33 POUNDS.....	\$ 45.72	28.19
34 - AND OVER.....	\$ 46.72	28.19
LABORER (Tunnel and Sewer)		
GROUP 1.....	\$ 42.72	28.19
GROUP 2.....	\$ 42.85	28.19
GROUP 3.....	\$ 42.95	28.19
GROUP 4.....	\$ 43.07	28.19
GROUP 5.....	\$ 42.72	28.19

LABORER CLASSIFICATIONS (TUNNEL)

GROUP 1: Cage tenders; Dumpmen; Flagmen; Signalmen; Top laborers

GROUP 2: Air hoist operator; Key board operator; concrete laborer; Grout; Lock tenders (Free Air Side); Steel

setters; Tuggers; Switchmen; Car pusher

GROUP 3: Concrete repairmen; Lock tenders (pressure side); Mortar men; Muckers; Grout machine operators; Track layers

GROUP 4: Air trac drill operator; Miner; Bricklayer tenders; Concrete blower operator; Drillers; Dynamiters; Erector operator; Form men; Jackhammermen; Powerpac; Mining machine operators; Mucking machine operator; Laser beam operator; Liner plate and ring setters; Shield drivers; Power knife operator; Welder- burners; Pipe jacking machine operator; skimmers; Maintenance technician

GROUP 5: Asbestos abatement laborer; Toxic and hazardous waste removal laborer; Dosimeter (any device) monitoring nuclear exposure

LABORER CLASSIFICATIONS (SEWER)

GROUP 1: Signalmen; Top laborers and All other laborers

GROUP 2: Concrete laborers and Steel setters

GROUP 3: Cement carriers; Cement mixers; Concrete repairmen; Mortar men; Scaffold men; Second Bottom men

GROUP 4: Air trac drill operator; Bottom men; Bracers-bracing; Bricklayer tenders; Catch basin diggers; Drainlayers; dynamiters; Form men; Jackhammermen; Powerpac; Pipelayers; Rodders; Welder-burners; Well point systems men

GROUP 5: Asbestos abatement laborer, Toxic and hazardous waste removal laborer; Dosimeter (any device) monitoring nuclear exposure

LAB00225-001 06/01/2018

	Rates	Fringes
LABORER (DEMOLITION/WRECKING)		
GROUP 1.....	\$ 37.52	28.19
GROUP 2.....	\$ 42.72	28.19
GROUP 3.....	\$ 42.72	28.19

LABORER CLASSIFICATIONS

GROUP 1 - Complete Demolition

GROUP 2 - Interior Wrecking and Strip Out Work

GROUP 3 - Asbestos Work with Complete Demolition/Wrecking or Strip Out Work

PAIN0014-001 06/01/2020

	Rates	Fringes
PAINTER (including taper).....	\$ 48.30	28.72

PAIN0027-001 06/01/2021

	Rates	Fringes
GLAZIER.....	\$ 47.73	39.84

PLAS0005-002 07/01/2015

	Rates	Fringes
PLASTERER.....	\$ 42.25	26.65

PLAS0502-001 06/01/2018

	Rates	Fringes
CEMENT MASON/CONCRETE FINISHER...	\$ 45.25	33.48

PLUM0130-001 06/01/2021

	Rates	Fringes
PLUMBER.....	\$ 52.80	34.67

PLUM0597-002 06/01/2021

	Rates	Fringes
PIPEFITTER.....	\$ 52.00	36.37

ROOF0011-001 12/01/2021

Rates Fringes

ROOFER.....	\$ 46.70	27.10
-------------	----------	-------

 SFIL0281-001 01/01/2022

	Rates	Fringes
--	-------	---------

SPRINKLER FITTER.....	\$ 52.25	33.55
-----------------------	----------	-------

 SHEE0073-001 06/01/2021

	Rates	Fringes
--	-------	---------

Sheet Metal Worker.....	\$ 47.50	41.67
-------------------------	----------	-------

 SHEE0073-002 06/08/2018

	Rates	Fringes
--	-------	---------

Sheet Metal Worker ALUMINUM GUTTER WORK.....	\$ 31.32	37.02
---	----------	-------

 TEAM0731-001 06/01/2017

COOK COUNTY - HEAVY AND HIGHWAY

	Rates	Fringes
--	-------	---------

TRUCK DRIVER		
2 or 3 Axles.....	\$ 35.60	22.10
4 Axles.....	\$ 35.85	22.10
5 Axles.....	\$ 36.05	22.10
6 Axles.....	\$ 36.25	22.10

FOOTNOTES:

A. Paid Holidays: New Year's Day, Memorial Day, Independence Day, Labor Day, Thanksgiving Day, and Christmas Day.

B. 900 straight time hours or more in 1 calendar year for the same employer shall receive 1 week paid vacation; 3 years - 2 weeks paid vacation; 10 years - 3 weeks paid vacation; 20 years - 4 weeks paid vacation.

C. An additional \$.20 per axle shall be paid for all vehicles with more than six (6) axles.

TEAM0731-002 04/01/2021

	Rates	Fringes
Traffic Control Device Monitor TRAFFIC SAFETY WORKER: Primary duties include but are not limited to the delivery, maintenance and pick-up of traffic control devices, the set-up and installation of traffic signs, pavement markings, barricades, crash barrels and glare screens, traffic control surveillance, the repair and maintenance trucks, cars, arrow boards, message signs, barricade and sign fabrication equipment.....	\$ 38.50	18.70

TEAM0786-001 06/01/2017

COOK COUNTY - BUILDING AND RESIDENTIAL

	Rates	Fringes
TRUCK DRIVER		
2 & 3 Axles.....	\$ 39.942	0.25+a
4 Axles.....	\$ 39.75	0.25+a
5 Axles.....	\$ 39.967	0.25+a
6 Axles.....	\$ 40.184	0.25+a

FOOTNOTES:

a. \$719.00 per week.

An additional \$.20 per axle shall be paid for all vehicles with more than six (6) axles.

Paid Holidays: New Year's Day, Memorial Day, Independence Day, Labor Day, Thanksgiving Day, and Christmas Day.

900 straight time hours or more in 1 calendar year for the

same employer shall receive 1 week paid vacation; 3 years - 2 weeks paid vacation; 10 years - 3 weeks paid vacation; 20 years - 4 weeks paid vacation.

WELDERS - Receive rate prescribed for craft performing operation to which welding is incidental.

=====
Note: Executive Order (EO) 13706, Establishing Paid Sick Leave for Federal Contractors applies to all contracts subject to the Davis-Bacon Act for which the contract is awarded (and any solicitation was issued) on or after January 1, 2017. If this contract is covered by the EO, the contractor must provide employees with 1 hour of paid sick leave for every 30 hours they work, up to 56 hours of paid sick leave each year.

Employees must be permitted to use paid sick leave for their own illness, injury or other health-related needs, including preventive care; to assist a family member (or person who is like family to the employee) who is ill, injured, or has other health-related needs, including preventive care; or for reasons resulting from, or to assist a family member (or person who is like family to the employee) who is a victim of, domestic violence, sexual assault, or stalking. Additional information on contractor requirements and worker protections under the EO is available at

<https://www.dol.gov/agencies/whd/government-contracts>.

Unlisted classifications needed for work not included within the scope of the classifications listed may be added after award only as provided in the labor standards contract clauses (29CFR 5.5 (a) (1) (ii)).

The body of each wage determination lists the classification and wage rates that have been found to be prevailing for the cited type(s) of construction in the area covered by the wage determination. The classifications are listed in alphabetical order of ""identifiers"" that indicate whether the particular rate is a union rate (current union negotiated rate for local), a survey rate (weighted average rate) or a union average rate (weighted union average rate).

Union Rate Identifiers

A four letter classification abbreviation identifier enclosed in dotted lines beginning with characters other than ""SU"" or ""UAVG"" denotes that the union classification and rate were prevailing for that classification in the survey. Example: PLUM0198-005 07/01/2014. PLUM is an abbreviation identifier of the union which prevailed in the survey for this classification, which in this example would be Plumbers. 0198 indicates the local union number or district council number where applicable, i.e., Plumbers Local 0198. The next number, 005 in the example, is an internal number used in processing the wage determination. 07/01/2014 is the effective date of the most current negotiated rate, which in this example is July 1, 2014.

Union prevailing wage rates are updated to reflect all rate changes in the collective bargaining agreement (CBA) governing this classification and rate.

Survey Rate Identifiers

Classifications listed under the ""SU"" identifier indicate that no one rate prevailed for this classification in the survey and the published rate is derived by computing a weighted average rate based on all the rates reported in the survey for that classification. As this weighted average rate includes all rates reported in the survey, it may include both union and non-union rates. Example: SULA2012-007 5/13/2014. SU indicates the rates are survey rates based on a weighted average calculation of rates and are not majority rates. LA indicates the State of Louisiana. 2012 is the year of survey on which these classifications and rates are based. The next number, 007 in the example, is an internal number used in producing the wage determination. 5/13/2014 indicates the survey completion date for the classifications and rates under that identifier.

Survey wage rates are not updated and remain in effect until a new survey is conducted.

Union Average Rate Identifiers

Classification(s) listed under the UAVG identifier indicate that no single majority rate prevailed for those classifications; however, 100% of the data reported for the classifications was union data. EXAMPLE: UAVG-OH-0010

08/29/2014. UAVG indicates that the rate is a weighted union average rate. OH indicates the state. The next number, 0010 in the example, is an internal number used in producing the wage determination. 08/29/2014 indicates the survey completion date for the classifications and rates under that identifier.

A UAVG rate will be updated once a year, usually in January of each year, to reflect a weighted average of the current negotiated/CBA rate of the union locals from which the rate is based.

WAGE DETERMINATION APPEALS PROCESS

1.) Has there been an initial decision in the matter? This can be:

- * an existing published wage determination
- * a survey underlying a wage determination
- * a Wage and Hour Division letter setting forth a position on a wage determination matter
- * a conformance (additional classification and rate) ruling

On survey related matters, initial contact, including requests for summaries of surveys, should be with the Wage and Hour National Office because National Office has responsibility for the Davis-Bacon survey program. If the response from this initial contact is not satisfactory, then the process described in 2.) and 3.) should be followed.

With regard to any other matter not yet ripe for the formal process described here, initial contact should be with the Branch of Construction Wage Determinations. Write to:

Branch of Construction Wage Determinations
Wage and Hour Division
U.S. Department of Labor
200 Constitution Avenue, N.W.
Washington, DC 20210

2.) If the answer to the question in 1.) is yes, then an interested party (those affected by the action) can request review and reconsideration from the Wage and Hour Administrator (See 29 CFR Part 1.8 and 29 CFR Part 7). Write to:

Wage and Hour Administrator
U.S. Department of Labor
200 Constitution Avenue, N.W.
Washington, DC 20210

The request should be accompanied by a full statement of the interested party's position and by any information (wage payment data, project description, area practice material, etc.) that the requestor considers relevant to the issue.

3.) If the decision of the Administrator is not favorable, an interested party may appeal directly to the Administrative Review Board (formerly the Wage Appeals Board). Write to:

Administrative Review Board
U.S. Department of Labor
200 Constitution Avenue, N.W.
Washington, DC 20210

4.) All decisions by the Administrative Review Board are final.

=====

END OF GENERAL DECISIO"

"General Decision Number: IL20220020 02/25/2022

Superseded General Decision Number: IL20210020

State: Illinois

Construction Types: Building Landscape, Heavy Landscape, Highway Landscape and Residential Landscape

Counties: Boone, Cook, De Kalb, Du Page, Grundy, Henry, Kane, Kankakee, Kendall, Lake, McHenry, McLean, Ogle, Peoria, Rock Island, Tazewell, Will, Winnebago and Woodford Counties in Illinois.

LANDSCAPING WORK ON BUILDING, RESIDENTIAL, HEAVY AND HIGHWAY CONSTRUCTION PROJECTS.

Note: Contracts subject to the Davis-Bacon Act are generally required to pay at least the applicable minimum wage rate required under Executive Order 14026 or Executive Order 13658. Please note that these Executive Orders apply to covered contracts entered into by the federal government that are subject to the Davis-Bacon Act itself, but do not apply to contracts subject only to the Davis-Bacon Related Acts, including those set forth at 29 CFR 5.1(a)(2)-(60).

<p>If the contract is entered into on or after January 30, 2022, or the contract is renewed or extended (e.g., an option is exercised) on or after January 30, 2022:</p>	<ul style="list-style-type: none"> . Executive Order 14026 generally applies to the contract. . The contractor must pay all covered workers at least \$15.00 per hour (or the applicable wage rate listed on this wage determination, if it is higher) for all hours spent performing on the contract in 2022.
<p>If the contract was awarded on or between January 1, 2015 and January 29, 2022, and the contract is not renewed or extended on or after January</p>	<ul style="list-style-type: none"> . Executive Order 13658 generally applies to the contract. . The contractor must pay all covered workers at least

30, 2022:	\$11.25 per hour (or the applicable wage rate listed on this wage determination, if it is higher) for all hours spent performing on that contract in 2022.
-----------	--

The applicable Executive Order minimum wage rate will be adjusted annually. If this contract is covered by one of the Executive Orders and a classification considered necessary for performance of work on the contract does not appear on this wage determination, the contractor must still submit a conformance request.

Additional information on contractor requirements and worker protections under the Executive Orders is available at <https://www.dol.gov/agencies/whd/government-contracts>.

Modification Number	Publication Date
0	01/07/2022
1	02/25/2022

ENGI0150-013 06/01/2021

BUILDING AND HIGHWAY CONSTRUCTION (LANDSCAPE WORK): The landscape work for the Landscape Equipment Operator excludes the preparation of sub-grade prior to application of finish landscape materials and the utilization of any equipment over one cubic yard.

BOONE, COOK, DUPAGE, GRUNDY, KANE, KENDALL, LAKE, MCHENRY, AND WILL COUNTIES

	Rates	Fringes
Operators:.....	\$ 34.55	8.00+A+B
Includes Angle Dozer, Small; Bobcat and other similar type machines, 1 cu yd or less; Chipping Machine; Combination Backhoe and Front End Loader 1 cu yd or less; Fork Lift Truck; Hi-Reach and High-Ranger;Hydraulic Boom with Clam;Log Skidder; Sttraw Blower and Seeder; Stump Machine;Tractors, Crawlers, Rubber Tire Tractors, Highlift Shovels or Front End Loaders 1 cu yd or less; Tree Spades, all; Utility Tractor and		

attachments, and Rubber Tire Front End loader or similar machine of 1 to 1.5 cu yd solely used for placement of large decorative boulders, trees with balled soil, and other decorative landscape material too large to be accommodated in a 1 cu yd bucket. All other equipment utilized for performing landscape work, tree trimming or removal of stees, and to install plants; transport trees; excavate plant pits; place soil and other landscape materials; and apply finish landscape material on subgrade prepared by others

FOOTNOTE:

A. Health and Welfare contribution is \$1,496.00 per month.

B. Paid Holidays: New Year's Day; Memorial Day; Fourth of July; Labor Day; Thanksgiving Day; and Christmas Day provided that all such employees shall have in fact worked their regularly scheduled work day immediately preceding and the regularly scheduled work day immediately succeeding the occurrence of such holiday.

ENGI0150-023 06/01/2021

HIGHWAY CONSTRUCTION (LANDSCAPE WORK): The landscape work for the Landscape Equipment Operator excludes the preparation of sub-grade prior to application of finish landscape materials and the utilization of any equipment over one cubic yard.

HENRY, MCLEAN, OGLE, PEORIA, ROCK ISLAND, TAZEWELL, WINNEBAGO, and WOODFORD COUNTIES

Rates Fringes

Operators:.....\$ 34.55 8.00+A+B

Includes the following: Angle Dozer, Small; Bobcat and other similar type machines, 1 cu yd or less; Chipping Machine; Combination Backhoe and Front End Loader 1 cu yd or less; Fork Lift Truck; Hi-Reach and High-Ranger;Hydraulic Boom with Clam;Log Skidder; Sttraw Blower and Seeder; Stump Machine;Tractors, Crawlers, Rubber Tire Tractors, Highlift Shovels or Front End Loaders 1 cu yd or less; Tree Spades, all; Utility Tractor and attachments, and Rubber Tire Front End loader or similar machine of 1 to 1.5 cu yd solely used

for placement of large decorative boulders, trees with balled soil, and other decorative landscape material too large to be accommodated in a 1 cu yd bucket. All other equipment utilized for performing landscape work, tree trimming or removal of stees, and to install plants; transport trees; excavate plant pits; place soil and other landscape materials; and apply finish landscape material on subgrade prepared by others

FOOTNOTE:

A. Health and Welfare contribution is \$1,496.00 per month.

B. Paid Holidays: New Year's Day; Memorial Day; Fourth of July; Labor Day; Thanksgiving Day; and Christmas Day provided that all such employees shall have in fact worked their regularly scheduled work day immediately preceding and the regularly scheduled work day immediately succeeding the occurrence of such holiday.

LAB00032-004 05/01/2021

HIGHWAY CONSTRUCTION

WINNEBAGO COUNTY

	Rates	Fringes
Landscape Laborer.....	\$ 38.75	34.91

LAB00362-003 05/01/2018

HIGHWAY CONSTRUCTION

MCLEAN COUNTY

	Rates	Fringes
Landscape Laborer.....	\$ 31.08	24.43

LAB00751-004 05/01/2021

HIGHWAY CONSTRUCTION

KANKAKEE COUNTY

	Rates	Fringes
Landscape Laborer.....	\$ 39.44	32.54

LAB00852-004 05/01/2006		

HIGHWAY CONSTRUCTION

ROCK ISLAND AND HENRY COUNTIES

	Rates	Fringes
Landscape Laborer.....	\$ 21.94	12.79

LAB00996-004 05/01/2018		

HIGHWAY CONSTRUCTION

PEORIA, TAZEWELL, AND WOODFORD COUNTIES

	Rates	Fringes
Landscape Laborer.....	\$ 32.73	23.74

TEAM0026-005 05/01/2020		

MCLEAN (South of a straight line from where Route 24 intersects the Woodford County line in a Southeast direction to the South Southwest corner of Livingston County) COUNTY

	Rates	Fringes
TRUCK DRIVER		
Group 1.....	\$ 38.93	20.39
Group 2.....	\$ 39.50	20.39
Group 3.....	\$ 39.77	20.39
Group 4.....	\$ 40.14	20.39
Group 5.....	\$ 41.21	20.39

CLASSIFICATIONS:

GROUP 1: Drivers on 2 axles hauling less than 9 tons; air compressor & welding machines and brooms, including those pulled by separate units; Truck Driver Helper, warehouse employees; Mechanic Helpers; greasers and tiremen; pick-up trucks when hauling material, tools, or workers to and from

and on the job site; and forklifts up to 6,000 lb capacity.

GROUP 2: 2 or 3 axles hauling more than 9 tons but hauling less than 16 tons; A-frame winch trucks; hydrolift trucks; Vactor Trucks or similar equipment when used for transportation purposes; Forklift over 6,000 lb.capacity; winch trucks; and four axle combination units.

GROUP 3: 2, 3 or 4 Axles hauling 16 tons or more; 5-Axles or more combination units; drivers on water pulls; articulated dump trucks; mechanics and working forepersons.

GROUP 4: Low Boy and Oil Distributors.

GROUP 5: Drivers who require special protective clothing while employed on hazardous waste work.

* TEAM0179-004 06/01/2017

GRUNDY, KENDALL, MCLEAN (North of a straight line starting at the intersection of McLean-Woodford Counties line & Route 24 in a Southeastern direction to the South Southwest corner of Livingston County), WILL, and WOODFORD (Northeast corner east of Route 51/251 & North of Route 24) COUNTIES

	Rates	Fringes
TRUCK DRIVER		
2-3 AXLES.....	\$ 37.68	0.15+a
4 AXLES.....	\$ 37.83	0.15+a
5 AXLES.....	\$ 38.03	0.15+a
6 AXLES.....	\$ 38.23	0.15+a

FOOTNOTES:

- a. \$733.20 per week.
- b. Lowboy rate based on number of axles

An additional \$.20 per axle shall be paid for all vehicles with more than six (6) axles.

CLASSIFICATIONS:

Group 1 - Frame Truck when used for transportation purposes; Air Compressor and Welding Machines, including those pulled by cars, pick-up trucks and tractors; Ambulances;

Articulated Dumps; Batch Gate Lockers; Batch Hopperman; Car and Truck Washers; Carry Alls; Forl Lifts and Hoisters; Helpers; Mechanics Helpers and Greasers; Oil Distributors, two-man operation; Pavement Breakers; Pole Trailer, up to 40 feet; Pothole Repair Trucks; Power Mower Tractors; Quick Change Barrier; Self-Propelled Chip Spreader; Shipping and Receiving Clerks and Checkers; Skipman; Slurry Trucks, two-man operation; Slurry Trucks, Conveyor Operated - 2 or 3 man operation; Teamsters; Unskilled Dumpmen; Warehousemen and Dockmen; Truck Drivers hauling warning lights, barricades, and portable toilets on the job site

Group 2 - Dispatcher; Dump Crets and Adgetators under 7 yards; Dumpsters, Track Trucks, Euclids, Hug Bottom Dump Turnapulls or Turnatrailers when pulling other than self-loading equipment or similar equipment under 16 cubic yards; Mixer Trucks under 7 yards; Ready-Mix Plant Hopper Operator; Winch Trucks, 2 Axles

Group 3 - Dump Crets and Adgetators, 7 yards and over; Dumpsters, Track Trucks, Euclids, Hug Bottom Dump Turnapulls or Turnatrailers when pulling other than self-loading equipment or similar equipment over 16 cubic yards; Explosives and/or Fission Material Trucks; Mixer Trucks 7 yards or over; Mobile Cranes while in transit; Oil Distributors, one-man operation; Pole Trailer, over 40 feet; Pole and Expandable Trailers hauling material over 50 feet long; Slurry Trucks, one-man operation; Winch Trucks, 3 axles or more; Mechanic - *Truck Welder and *Truck Painter*These classifications shall only apply in areas where and when it has been a past area practice; Asphalt Plant Operators in areas where it has been past practice

Group 4 - Dual-purpose vehicels, such as mounted crane tucks with hoist and accessories; Foreman; Master Mechanic; Self-loading equipment like P.B. and trucks with scoops on the front

* TEAM0179-008 06/01/2019

KANKAKEE COUNTY

Rates

Fringes

TRUCK DRIVER

2 or 3 axles.....	\$ 39.20	0.25+a
4 axles.....	\$ 39.35	0.25+a
5 axles.....	\$ 39.55	0.25+a
6 axles.....	\$ 39.75	0.25+a
All Lowboy Trucks.....	\$ 39.75	0.25+a

FOOTNOTES:

a. \$829.20 per week.

An additional \$.20 per axle shall be paid for all vehicles with more than six (6) axles.

CLASSIFICATIONS:

Group 1 - Frame Truck when used for transportation purposes; Air Compressor and Welding Machines, including those pulled by cars, pick-up trucks and tractors; Ambulances; Articulated Dumps; Batch Gate Lockers; Batch Hopperman; Car and Truck Washers; Carry Alls; Forl Lifts and Hoisters; Helpers; Mechanics Helpers and Greasers; Oil Distributors, two-man operation; Pavement Breakers; Pole Trailer, up to 40 feet; Pothole Repair Trucks; Power Mower Tractors; Quick Change Barrier; Self-Propelled Chip Spreader; Shipping and Receiving Clerks and Checkers; Skipman; Slurry Trucks, two-man operation; Slurry Trucks, Conveyor Operated - 2 or 3 man operation; Teamsters; Unskilled Dumpmen; Warehousemen and Dockmen; Truck Drivers hauling warning lights, barricades, and portable toilets on the job site

Group 2 - Dispatcher; Dump Crets and Adgetators under 7 yards; Dumpsters, Track Trucks, Euclids, Hug Bottom Dump Turnapulls or Turnatrailers when pulling other than self-loading equipment or similar equipment under 16 cubic yards; Mixer Trucks under 7 yards; Ready-Mix Plant Hopper Operator; Winch Trucks, 2 Axles

Group 3 - Dump Crets and Adgetators, 7 yards and over; Dumpsters, Track Trucks, Euclids, Hug Bottom Dump Turnapulls or Turnatrailers when pulling other than self-loading equipment or similar equipment over 16 cubic yards; Explosives and/or Fission Material Trucks; Mixer Trucks 7 yards or over; Mobile Cranes while in transit; Oil Distributors, one-man operation; Pole Trailer, over 40 feet; Pole and Expandable Trailers hauling material over 50 feet long; Slurry Trucks, one-man operation; Winch Trucks, 3 axles or

more; Mechanic - *Truck Welder and *Truck Painter*These classifications shall only apply in areas where and when it has been a past area practice; Asphalt Plant Operators in areas where it has been past practice

Group 4 - Dual-purpose vehicels, such as mounted crane tucks with hoist and accessories; Foreman; Master Mechanic; Self-loading equipment like P.B. and trucks with scoops on the front

* TEAM0301-001 06/01/2019

LAKE AND MCHENRY COUNTIES

	Rates	Fringes
TRUCK DRIVER		
2-3 AXLES.....	\$ 39.34	10.75+a
4 AXLES.....	\$ 39.49	10.75+a
5 AXLES.....	\$ 39.69	10.75+a
6 AXLES.....	\$ 39.89	10.75+a

FOOTNOTES:

- a. 380.00 per week pension.
- b. Lowboy rate based on number of axles

An additional \$.20 per axle shall be paid for all vehicles with more than six (6) axles.

Paid Holidays: New Year's Day, Memorial Day, Independence Day, Labor Day, Thanksgiving Day, and Christmas Day.

900 straight time hours or more in 1 calendar year for the same employer shall receive 1 week paid vacation; 3 years - 2 weeks paid vacation; 10 years - 3 weeks paid vacation; 20 years - 4 weeks paid vacation.

CLASSIFICATIONS:

Group 1 - Frame Truck when used for transportation purposes; Air Compressor and Welding Machines, including those pulled by cars, pick-up trucks and tractors; Ambulances; Articulated Dumps; Batch Gate Lockers; Batch Hopperman; Car and Truck Washers; Carry Alls; Forl Lifts and Hoisters; Helpers; Mechanics Helpers and Greasers; Oil Distributors, two-man operation; Pavement Breakers; Pole Trailer, up to

40 feet; Pothole Repair Trucks; Power Mower Tractors; Quick Change Barrier; Self-Propelled Chip Spreader; Shipping and Receiving Clerks and Checkers; Skipman; Slurry Trucks, two-man operation; Slurry Trucks, Conveyor Operated - 2 or 3 man operation; Teamsters; Unskilled Dumpmen; Warehousemen and Dockmen; Truck Drivers hauling warning lights, barricades, and portable toilets on the job site

Group 2 - Dispatcher; Dump Crets and Adgetators under 7 yards; Dumpsters, Track Trucks, Euclids, Hug Bottom Dump Turnapulls or Turnatrailers when pulling other than self-loading equipment or similar equipment under 16 cubic yards; Mixer Trucks under 7 yards; Ready-Mix Plant Hopper Operator; Winch Trucks, 2 Axles

Group 3 - Dump Crets and Adgetators, 7 yards and over; Dumpsters, Track Trucks, Euclids, Hug Bottom Dump Turnapulls or Turnatrailers when pulling other than self-loading equipment or similar equipment over 16 cubic yards; Explosives and/or Fission Material Trucks; Mixer Trucks 7 yards or over; Mobile Cranes while in transit; Oil Distributors, one-man operation; Pole Trailer, over 40 feet; Pole and Expandable Trailers hauling material over 50 feet long; Slurry Trucks, one-man operation; Winch Trucks, 3 axles or more; Mechanic - *Truck Welder and *Truck Painter*These classifications shall only apply in areas where and when it has been a past area practice; Asphalt Plant Operators in areas where it has been past practice

Group 4 - Dual-purpose vehicels, such as mounted crane tucks with hoist and accessories; Foreman; Master Mechanic; Self-loading equipment like P.B. and trucks with scoops on the front

* TEAM0325-004 06/01/2020

BOONE and WINNEBAGO COUNTIES

	Rates	Fringes
TRUCK DRIVER		
2 - 3 Axles.....	\$ 39.87	22.60
4 Axles.....	\$ 40.02	22.60
5 Axles.....	\$ 40.22	22.60
6 Axles.....	\$ 40.33	22.60

FOOTNOTE: An additional \$.20 per axle shall be paid for all vehicles with more than six (6) axles.

CLASSIFICATIONS:

Group 1 - Frame Truck when used for transportation purposes; Air Compressor and Welding Machines, including those pulled by cars, pick-up trucks and tractors; Ambulances; Batch Gate Lockers; Batch Hopperman; Car and Truck Washers; Forl Lifts and Hoisters; Helpers; Mechanics Helpers and Greasers; Oil Distributors, two-man operation; Pavement Breakers Pole Trailer, up to 40 feet; Power Mower Tractors; Skipman; Slurry Trucks, two-man operation; Teamsters; Truck Drivers hauling warning lights, barricades, and portable toilets on the job site

Group 2 - Dump Crets and Adgetators under 7 yards; Dumpsters, Track Trucks, Euclids, Hug Bottom Dump Turnapulls or Turnatrailers when pulling other than self-loading equipment or similar equipment under 16 cubic yards; Mixer Trucks under 7 yards; Ready-Mix Plant Hopper Operator; Winch Trucks, 2 Axles

Group 3 - Dump Crets and Adgetators, 7 yards and over; Dumpsters, Track Trucks, Euclids, Hug Bottom Dump Turnapulls or Turnatrailers when pulling other than self-loading equipment or similar equipment over 16 cubic yards; Explosives and/or Fission Material Trucks; Mixer Trucks 7 yards or over; Mobile Cranes while in transit; Oil Distributors, one-man operation Pole Trailer, over 40 feet; Pole and Expandable Trailers hauling material over 50 feet long, additional \$0.50 per hour; Slurry Trucks, one-man operation; Winch Trucks, 3 axles or more
*Mechanic*Truck Welder and Truck Painter; *Winter Rate: Between Dec. 15 and Feb. 28 the mechanic and welder rate shall be \$2.00 less than the scheduled scale. Truck Painter and Truck Welder classifications shall only apply in areas where and when it has been a past area practice; Dual-purpose vehicels, such as mounted crane tucks with hoist and accessories

Group 4 - Foreman; Master Mechanic; Self-loading equipment like P.B. and trucks with scoops on the front

* TEAM0330-004 06/01/2017

DEKALB and OGLE (North of Route 72/East of Route 251, Adeline, Byron, Creston, Dement, Forreston North of Route 72, Leaf River North of Route 72, Lynnville, Monroe, Rochelle, & Scott) COUNTIES

	Rates	Fringes
TRUCK DRIVER		
2-3 AXLES.....	\$ 36.64	0.15+a
4 AXLES.....	\$ 36.79	0.15+a
5 AXLES.....	\$ 36.99	0.15+a
6 AXLES.....	\$ 37.19	0.15+a

FOOTNOTE: a. \$780.90 per week

An additional \$.20 per axle shall be paid for all vehicles with more than six (6) axles.

Paid Holidays: New Year's Day, Memorial Day, Independence Day, Labor Day, Thanksgiving Day, and Christmas Day.

900 straight time hours or more in 1 calendar year for the same employer shall receive 1 week paid vacation; 3 years - 2 weeks paid vacation; 10 years - 3 weeks paid vacation; 20 years - 4 weeks paid vacation.

CLASSIFICATIONS:

Group 1 - Frame Truck when used for transportation purposes; Air Compressor and Welding Machines, including those pulled by cars, pick-up trucks and tractors; Ambulances; Articulated Dumps; Batch Gate Lockers; Batch Hopperman; Car and Truck Washers; Carry Alls; Forl Lifts and Hoisters; Helpers; Mechanics Helpers and Greasers; Oil Distributors, two-man operation; Pavement Breakers; Pole Trailer, up to 40 feet; Pothole Repair Trucks; Power Mower Tractors; Quick Change Barrier; Self-Propelled Chip Spreader; Shipping and Receiving Clerks and Checkers; Skipman; Slurry Trucks, two-man operation; Slurry Trucks, Conveyor Operated - 2 or 3 man operation; Teamsters; Unskilled Dumpmen; Warehousemen and Dockmen; Truck Drivers hauling warning lights, barricades, and portable toilets on the job site

Group 2 - Dispatcher; Dump Crets and Adgetators under 7 yards; Dumpsters, Track Trucks, Euclids, Hug Bottom Dump Turnapulls or Turnatrailers when pulling other than self-loading equipment or similar equipment under 16 cubic yards; Mixer Trucks under 7 yards; Ready-Mix Plant Hopper Operator; Winch Trucks, 2 Axles

Group 3 - Dump Crets and Adgetators, 7 yards and over; Dumpsters, Track Trucks, Euclids, Hug Bottom Dump Turnapulls or Turnatrailers when pulling other than self-loading equipment or similar equipment over 16 cubic yards; Explosives and/or Fission Material Trucks; Mixer Trucks 7 yards or over; Mobile Cranes while in transit; Oil Distributors, one-man operation; Pole Trailer, over 40 feet; Pole and Expandable Trailers hauling material over 50 feet long; Slurry Trucks, one-man operation; Winch Trucks, 3 axles or more; Mechanic - *Truck Welder and *Truck Painter*These classifications shall only apply in areas where and when it has been a past area practice; Asphalt Plant Operators in areas where it has been past practice

Group 4 - Dual-purpose vehicels, such as mounted crane tucks with hoist and accessories; Foreman; Master Mechanic; Self-loading equipment like P.B. and trucks with scoops on the front

TEAM0371-004 05/01/2020

HENRY and ROCK ISLAND COUNTIES

	Rates	Fringes
TRUCK DRIVER		
Group 1.....	\$ 39.04	20.63
Group 2.....	\$ 39.60	20.63
Group 3.....	\$ 39.91	20.63
Group 4.....	\$ 40.25	20.63
Group 5.....	\$ 41.33	20.63

CLASSIFICATIONS:

GROUP 1: Drivers on 2 axles hauling less than 9 tons; air compressor & welding machines and brooms, including those pulled by separate units; Truck Driver Helper, warehouse employees; Mechanic Helpers; greasers and tiremen; pick-up

trucks when hauling material, tools, or workers to and from and on the job site; and forklifts up to 6,000 lb capacity.

GROUP 2: 2 or 3 axles hauling more than 9 tons but hauling less than 16 tons; A-frame winch trucks; hydrolift trucks; Vactor Trucks or similar equipment when used for transportation purposes; Forklift over 6,000 lb.capacity; winch trucks; and four axle combination units.

GROUP 3: 2, 3 or 4 Axles hauling 16 tons or more; 5-Axles or more combination units; drivers on water pulls; articulated dump trucks; mechanics and working forepersons.

GROUP 4: Low Boy and Oil Distributors.

GROUP 5: Drivers who require special protective clothing while employed on hazardous waste work.

TEAM0627-004 05/01/2019

PEORIA, TAZEWELL, and WOODFORD COUNTIES

	Rates	Fringes
TRUCK DRIVER		
Group 1.....	\$ 38.06	19.62
Group 2.....	\$ 38.61	19.62
Group 3.....	\$ 38.87	19.62
Group 4.....	\$ 39.23	19.62
Group 5.....	\$ 40.27	19.62

CLASSIFICATIONS:

GROUP 1: Drivers on 2 axles hauling less than 9 tons; air compressor & welding machines and brooms, including those pulled by separate units; Truck Driver Helper, warehouse employees; Mechanic Helpers; greasers and tiremen; pick-up trucks when hauling material, tools, or workers to and from and on the job site; and forklifts up to 6,000 lb capacity.

GROUP 2: 2 or 3 axles hauling more than 9 tons but hauling less than 16 tons; A-frame winch trucks; hydrolift trucks; Vactor Trucks or similar equipment when used for transportation purposes; Forklift over 6,000 lb.capacity; winch trucks; and four axle combination units.

GROUP 3: 2, 3 or 4 Axles hauling 16 tons or more; 5-Axles or more combination units; drivers on water pulls; articulated dump trucks; mechanics and working forepersons.

GROUP 4: Low Boy and Oil Distributors.

GROUP 5: Drivers who require special protective clothing while employed on hazardous waste work.

* TEAM0673-003 06/01/2019

DU PAGE and KANE COUNTIES

	Rates	Fringes
TRUCK DRIVER		
2-3 AXLES.....	\$ 38.47	0.25+a
4 AXLES.....	\$ 38.62	0.25+a
5 AXLES.....	\$ 38.82	0.25+a
6 AXLES.....	\$ 39.02	0.25+a

FOOTNOTE: a. \$861.10 per week.

An additional \$.20 per axle shall be paid for all vehicles with more than six (6) axles.

Paid Holidays: New Year's Day, Memorial Day, Independence Day, Labor Day, Thanksgiving Day, and Christmas Day.

900 straight time hours or more in 1 calendar year for the same employer shall receive 1 week paid vacation; 3 years - 2 weeks paid vacation; 10 years - 3 weeks paid vacation; 20 years - 4 weeks paid vacation.

CLASSIFICATIONS:

Group 1 - Frame Truck when used for transportation purposes; Air Compressor and Welding Machines, including those pulled by cars, pick-up trucks and tractors; Ambulances; Articulated Dumps; Batch Gate Lockers; Batch Hopperman; Car and Truck Washers; Carry Aalls; Forl Lifts and Hoisters; Helpers; Mechanics Helpers and Greasers; Oil Distributors, two-man operation; Pavement Breakers; Pole Trailer, up to 40 feet; Pothole Repair Trucks; Power Mower Tractors; Quick Change Barrier; Self-Propelled Chip Spreader; Shipping and Receiving Clerks and Checkers; Skipman; Slurry Trucks,

two-man operation; Slurry Trucks, Conveyor Operated - 2 or 3 man operation; Teamsters; Unskilled Dumpmen; Warehousemen and Dockmen; Truck Drivers hauling warning lights, barricades, and portable toilets on the job site

Group 2 - Dispatcher; Dump Crets and Adgetators under 7 yards; Dumpsters, Track Trucks, Euclids, Hug Bottom Dump Turnapulls or Turnatrailers when pulling other than self-loading equipment or similar equipment under 16 cubic yards; Mixer Trucks under 7 yards; Ready-Mix Plant Hopper Operator; Winch Trucks, 2 Axles

Group 3 - Dump Crets and Adgetators, 7 yards and over; Dumpsters, Track Trucks, Euclids, Hug Bottom Dump Turnapulls or Turnatrailers when pulling other than self-loading equipment or similar equipment over 16 cubic yards; Explosives and/or Fission Material Trucks; Mixer Trucks 7 yards or over; Mobile Cranes while in transit; Oil Distributors, one-man operation; Pole Trailer, over 40 feet; Pole and Expandable Trailers hauling material over 50 feet long; Slurry Trucks, one-man operation; Winch Trucks, 3 axles or more; Mechanic - *Truck Welder and *Truck Painter*These classifications shall only apply in areas where and when it has been a past area practice; Asphalt Plant Operators in areas where it has been past practice

Group 4 - Dual-purpose vehicels, such as mounted crane tucks with hoist and accessories; Foreman; Master Mechanic; Self-loading equipment like P.B. and trucks with scoops on the front

TEAM0722-005 05/01/2015

OGLE (North of Route 72/East of Route 251) COUNTY

	Rates	Fringes
TRUCK DRIVER		
Group 1.....	\$ 34.10	17.09
Group 2.....	\$ 34.60	17.09
Group 3.....	\$ 34.82	17.09
Group 4.....	\$ 35.14	17.09
Group 5.....	\$ 36.06	17.09

CLASSIFICATIONS:

GROUP 1: Drivers on 2 axles hauling less than 9 tons; air compressor & welding machines and brooms, including those pulled by separate units; Truck Driver Helper, warehouse employees; Mechanic Helpers; greasers and tiremen; pick-up trucks when hauling material, tools, or workers to and from and on the job site; and forklifts up to 6,000 lb capacity.

GROUP 2: 2 or 3 axles hauling more than 9 tons but hauling less than 16 tons; A-frame winch trucks; hydrolift trucks; Vactor Trucks or similar equipment when used for transportation purposes; Forklift over 6,000 lb.capacity; winch trucks; and four axle combination units.

GROUP 3: 2, 3 or 4 Axles hauling 16 tons or more; 5-Axles or more combination units; drivers on water pulls; articulated dump trucks; mechanics and working forepersons.

GROUP 4: Low Boy and Oil Distributors.

GROUP 5: Drivers who require special protective clothing while employed on hazardous waste work.

TEAM0731-001 06/01/2017

COOK COUNTY - HEAVY AND HIGHWAY

	Rates	Fringes
TRUCK DRIVER		
2 or 3 Axles.....	\$ 35.60	22.10
4 Axles.....	\$ 35.85	22.10
5 Axles.....	\$ 36.05	22.10
6 Axles.....	\$ 36.25	22.10

FOOTNOTES:

A. Paid Holidays: New Year's Day, Memorial Day, Independence Day, Labor Day, Thanksgiving Day, and Christmas Day.

B. 900 straight time hours or more in 1 calendar year for the same employer shall receive 1 week paid vacation; 3 years - 2 weeks paid vacation; 10 years - 3 weeks paid vacation; 20 years - 4 weeks paid vacation.

C. An additional \$.20 per axle shall be paid for all vehicles with more than six (6) axles.

TEAM0786-001 06/01/2017

COOK COUNTY - BUILDING AND RESIDENTIAL

	Rates	Fringes
TRUCK DRIVER		
2 & 3 Axles.....	\$ 39.942	0.25+a
4 Axles.....	\$ 39.75	0.25+a
5 Axles.....	\$ 39.967	0.25+a
6 Axles.....	\$ 40.184	0.25+a

FOOTNOTES:

a. \$719.00 per week.

An additional \$.20 per axle shall be paid for all vehicles with more than six (6) axles.

Paid Holidays: New Year's Day, Memorial Day, Independence Day, Labor Day, Thanksgiving Day, and Christmas Day.

900 straight time hours or more in 1 calendar year for the same employer shall receive 1 week paid vacation; 3 years - 2 weeks paid vacation; 10 years - 3 weeks paid vacation; 20 years - 4 weeks paid vacation.

* SUIL1993-001 01/19/1993

BUILDING CONSTRUCTION (LANDSCAPE WORK):

	Rates	Fringes
LABORER		
BOONE, GRUNDY, KANE, KENDALL, LAKE, MCHENRY, & WILL COUNTIES		
LANDSCAPE LABORERS.....	\$ 7.25 **	
COOK COUNTY		
LANDSCAPE LABORERS.....	\$ 7.25 **	
LANDSCAPE PLANTSMAN.....	\$ 9.80 **	1.82
DE KALB COUNTY		

LANDSCAPE LABORERS.....	\$ 7.25 **	
LANDSCAPE OPERATORS.....	\$ 7.25 **	
LANDSCAPE PLANTSMAN.....	\$ 9.66 **	.26
DU PAGE COUNTY		
LANDSCAPE LABORERS.....	\$ 7.25 **	
LANDSCAPE PLANTSMAN.....	\$ 9.04 **	1.16
GRUNDY, LAKE & WILL COUNTIES		
LANDSCAPE DRIVER 2 & 3 Axles.....		
	\$ 11.86 **	2.81
LANDSCAPE PLANTSMAN.....	\$ 12.00 **	3.32

* SUIL1993-002 01/19/1993

HEAVY CONSTRUCTION (LANDSCAPE WORK)

	Rates	Fringes
LABORER		
BOONE, GRUNDY, KANE, KENDALL, LAKE, MCHENRY & WILL COUNTIES:		
LANDSCAPE DRIVER, 2 & 3 AXLES.....		
	\$ 11.94 **	2.42
LANDSCAPE LABORERS.....	\$ 7.25 **	
LANDSCAPE OPERATORS.....	\$ 13.11 **	3.01
LANDSCAPE PLANTSMAN.....	\$ 9.73 **	2.05
COOK COUNTY:		
LANDSCAPE DRIVER, 2 & 3 AXLES.....		
	\$ 9.93 **	1.89
LANDSCAPE LABORERS.....	\$ 7.25 **	
LANDSCAPE OPERATORS.....	\$ 10.98 **	2.12
LANDSCAPE PLANTSMAN.....	\$ 10.08 **	2.06
DE KALB COUNTY:		
LANDSCAPE LABORERS.....	\$ 7.25 **	
LANDSCAPE OPERATORS.....	\$ 7.25 **	
LANDSCAPE PLANTSMAN.....	\$ 9.66 **	.26
DU PAGE COUNTY:		
LANDSCAPE DRIVER, 2 & 3 AXLES.....		
	\$ 8.32 **	1.02
LANDSCAPE LABORERS.....	\$ 7.25 **	
LANDSCAPE OPERATORS.....	\$ 10.75 **	
LANDSCAPE PLANTSMAN.....	\$ 10.65 **	

* SUIL1993-003 01/19/1993

HIGHWAY CONSTRUCTION (LANDSCAPE WORK):

	Rates	Fringes
LABORER		
DE KALB COUNTY		
LANDSCAPE LABORERS.....	\$ 7.25 **	
LANDSCAPE OPERATORS.....	\$ 7.25 **	
LANDSCAPE PLANTSMAN.....	\$ 9.66 **	.26
KANKAKEE COUNTY:		
LANDSCAPE DRIVER.....	\$ 8.75 **	.17
LANDSCAPE OPERATOR.....	\$ 16.57	3.56
PEORIA, TAZEWELL, & WOODFORD COUNTIES:		
TRUCK DRIVERS 2 & 3 AXLES..	\$ 17.58	5.88

WELDERS - Receive rate prescribed for craft performing operation to which welding is incidental.

=====
 ** Workers in this classification may be entitled to a higher minimum wage under Executive Order 14026 (\$15.00) or 13658 (\$11.25). Please see the Note at the top of the wage determination for more information.

Note: Executive Order (EO) 13706, Establishing Paid Sick Leave for Federal Contractors applies to all contracts subject to the Davis-Bacon Act for which the contract is awarded (and any solicitation was issued) on or after January 1, 2017. If this contract is covered by the EO, the contractor must provide employees with 1 hour of paid sick leave for every 30 hours they work, up to 56 hours of paid sick leave each year. Employees must be permitted to use paid sick leave for their own illness, injury or other health-related needs, including preventive care; to assist a family member (or person who is like family to the employee) who is ill, injured, or has other health-related needs, including preventive care; or for reasons resulting from, or to assist a family member (or person who is like family to the employee) who is a victim of, domestic violence, sexual assault, or stalking. Additional information on contractor requirements and worker protections under the EO is available at <https://www.dol.gov/agencies/whd/government-contracts>.

Unlisted classifications needed for work not included within the scope of the classifications listed may be added after

award only as provided in the labor standards contract clauses (29CFR 5.5 (a) (1) (ii)).

The body of each wage determination lists the classification and wage rates that have been found to be prevailing for the cited type(s) of construction in the area covered by the wage determination. The classifications are listed in alphabetical order of ""identifiers"" that indicate whether the particular rate is a union rate (current union negotiated rate for local), a survey rate (weighted average rate) or a union average rate (weighted union average rate).

Union Rate Identifiers

A four letter classification abbreviation identifier enclosed in dotted lines beginning with characters other than ""SU"" or ""UAVG"" denotes that the union classification and rate were prevailing for that classification in the survey. Example: PLUM0198-005 07/01/2014. PLUM is an abbreviation identifier of the union which prevailed in the survey for this classification, which in this example would be Plumbers. 0198 indicates the local union number or district council number where applicable, i.e., Plumbers Local 0198. The next number, 005 in the example, is an internal number used in processing the wage determination. 07/01/2014 is the effective date of the most current negotiated rate, which in this example is July 1, 2014.

Union prevailing wage rates are updated to reflect all rate changes in the collective bargaining agreement (CBA) governing this classification and rate.

Survey Rate Identifiers

Classifications listed under the ""SU"" identifier indicate that no one rate prevailed for this classification in the survey and the published rate is derived by computing a weighted average rate based on all the rates reported in the survey for that classification. As this weighted average rate includes all rates reported in the survey, it may include both union and non-union rates. Example: SULA2012-007 5/13/2014. SU indicates the rates are survey rates based on a weighted average calculation of rates and are not majority rates. LA indicates

the State of Louisiana. 2012 is the year of survey on which these classifications and rates are based. The next number, 007 in the example, is an internal number used in producing the wage determination. 5/13/2014 indicates the survey completion date for the classifications and rates under that identifier.

Survey wage rates are not updated and remain in effect until a new survey is conducted.

Union Average Rate Identifiers

Classification(s) listed under the UAVG identifier indicate that no single majority rate prevailed for those classifications; however, 100% of the data reported for the classifications was union data. EXAMPLE: UAVG-OH-0010 08/29/2014. UAVG indicates that the rate is a weighted union average rate. OH indicates the state. The next number, 0010 in the example, is an internal number used in producing the wage determination. 08/29/2014 indicates the survey completion date for the classifications and rates under that identifier.

A UAVG rate will be updated once a year, usually in January of each year, to reflect a weighted average of the current negotiated/CBA rate of the union locals from which the rate is based.

WAGE DETERMINATION APPEALS PROCESS

1.) Has there been an initial decision in the matter? This can be:

- * an existing published wage determination
- * a survey underlying a wage determination
- * a Wage and Hour Division letter setting forth a position on a wage determination matter
- * a conformance (additional classification and rate) ruling

On survey related matters, initial contact, including requests for summaries of surveys, should be with the Wage and Hour National Office because National Office has responsibility for the Davis-Bacon survey program. If the response from this initial contact is not satisfactory, then the process described in 2.) and 3.) should be followed.

With regard to any other matter not yet ripe for the formal process described here, initial contact should be with the Branch of Construction Wage Determinations. Write to:

Branch of Construction Wage Determinations
Wage and Hour Division
U.S. Department of Labor
200 Constitution Avenue, N.W.
Washington, DC 20210

2.) If the answer to the question in 1.) is yes, then an interested party (those affected by the action) can request review and reconsideration from the Wage and Hour Administrator (See 29 CFR Part 1.8 and 29 CFR Part 7). Write to:

Wage and Hour Administrator
U.S. Department of Labor
200 Constitution Avenue, N.W.
Washington, DC 20210

The request should be accompanied by a full statement of the interested party's position and by any information (wage payment data, project description, area practice material, etc.) that the requestor considers relevant to the issue.

3.) If the decision of the Administrator is not favorable, an interested party may appeal directly to the Administrative Review Board (formerly the Wage Appeals Board). Write to:

Administrative Review Board
U.S. Department of Labor
200 Constitution Avenue, N.W.
Washington, DC 20210

4.) All decisions by the Administrative Review Board are final.

=====

END OF GENERAL DECISIO"

SECTION 3 CLAUSE

Requirements ([24 CFR § 75.19](#))

(a) *Employment and training.*

(1) To the greatest extent feasible, and consistent with existing Federal, state, and local laws and regulations, contractors covered by this subpart shall ensure that employment and training opportunities arising in connection with Section 3 projects are provided to Section 3 workers within the metropolitan area (or nonmetropolitan county) in which the project is located.

(2) Where feasible, priority for opportunities and training should be given to:

(i) Section 3 workers residing within the service area or the neighborhood of the project, and

(ii) Participants in YouthBuild programs.

(b) *Contracting.*

(1) To the greatest extent feasible, and consistent with existing Federal, state, and local laws and regulations, recipients covered by this subpart shall ensure contracts for work awarded in connection with Section 3 projects are provided to business concerns that provide economic opportunities to Section 3 workers residing within the metropolitan area (or nonmetropolitan county) in which the project is located.

(2) Where feasible, priority for contracting opportunities described in [paragraph \(b\)\(1\)](#) of this section should be given to:

(i) Section 3 business concerns that provide economic opportunities to Section 3 workers residing within the service area or the neighborhood of the project, and

(ii) YouthBuild programs.

Targeted Section 3 worker for housing and community development financial assistance ([24 CFR § 75.21](#))

(a) **Targeted Section 3 worker.** A Targeted Section 3 worker for housing and community development financial assistance means a Section 3 worker who is:

- (1) A worker employed by a Section 3 business concern; or
- (2) A worker who currently fits or when hired fit at least one of the following categories, as documented within the past five years:
 - (i) Living within the service area or the neighborhood of the project, as defined in [§ 75.5](#); or
 - (ii) A YouthBuild participant.
- (b) [Reserved]

Section 3 safe harbor ([24 CFR § 75.23](#))

(a) **General.** Recipients will be considered to have complied with requirements in this part, in the absence of evidence to the contrary if they:

- (1) Certify that they have followed the prioritization of effort in [§ 75.19](#); and
- (2) Meet or exceed the applicable Section 3 benchmark as described in [paragraph \(b\)](#) of this section.

(b) **Establishing benchmarks.**

(1) HUD will establish Section 3 benchmarks for Section 3 workers or Targeted Section 3 workers or both through a document published in the Federal Register. HUD may establish a single nationwide benchmark for Section 3 workers and a single nationwide benchmark for Targeted Section 3 workers, or may establish multiple benchmarks based on geography, the nature of the Section 3 project, or other variables. HUD will update the benchmarks through a document published in the Federal Register, subject to public comment, not less frequently than once every 3 years. Such notice shall include aggregate data on labor hours and the proportion of recipients meeting benchmarks, as well as other metrics reported pursuant to [§ 75.25](#) as deemed appropriate by HUD, for the 3 most recent reporting years.

(2) In establishing the Section 3 benchmarks, HUD may consider the industry averages for labor hours worked by specific categories of workers or in different localities or regions; averages for labor hours worked by Section 3 workers and Targeted Section 3 workers as reported by recipients pursuant to this section; and any other factors HUD deems important. In establishing the Section 3 benchmarks, HUD will exclude professional services from the total number of labor hours as such hours are excluded from the total number of labor hours to be reported per [§ 75.25\(a\)\(4\)](#).

(3) Section 3 benchmarks will consist of the following two ratios:

- (i) The number of labor hours worked by Section 3 workers divided by the total number of labor hours worked by all workers on a Section 3 project in the recipient's program year.

(ii) The number of labor hours worked by Targeted Section 3 workers as defined in [§ 75.21\(a\)](#), divided by the total number of labor hours worked by all workers on a Section 3 project in the recipient's program year.

Reporting of labor hours ([24 CFR § 75.25](#))

(1) For Section 3 projects, recipients must report in a manner prescribed by HUD:

(i) The total number of labor hours worked;

(ii) The total number of labor hours worked by Section 3 workers; and

(iii) The total number of labor hours worked by Targeted Section 3 workers.

(2) Section 3 workers' and Targeted Section 3 workers' labor hours may be counted for five years from when their status as a Section 3 worker or Targeted Section 3 worker is established pursuant to [§ 75.31](#).

(3) The labor hours reported under [paragraph \(a\)\(1\)](#) of this section must include the total number of labor hours worked on a Section 3 project, including labor hours worked by any subrecipients, contractors and subcontractors that the recipient is required, or elects pursuant to [paragraph \(a\)\(4\)](#) of this section, to report.

(4) Recipients reporting under this section, as well as subrecipients, contractors and subcontractors who report to recipients, may report labor hours by Section 3 workers, under [paragraph \(a\)\(1\)\(ii\)](#) of this section, and labor hours by Targeted Section 3 workers, under [paragraph \(a\)\(1\)\(iii\)](#) of this section, from professional services without including labor hours from professional services in the total number of labor hours worked under [paragraph \(a\)\(1\)\(i\)](#) of this section. If a contract covers both professional services and other work and the recipient or contractor or subcontractor chooses not to report labor hours from professional services, the labor hours under the contract that are not from professional services must still be reported.

(5) Recipients may report their own labor hours or that of a subrecipient, contractor, or subcontractor based on the employer's good faith assessment of the labor hours of a full-time or part-time employee informed by the employer's existing salary or time and attendance based payroll systems, unless the project or activity is otherwise subject to requirements specifying time and attendance reporting.

(b) **Additional reporting if Section 3 benchmarks are not met.** If the recipient's reporting under [paragraph \(a\)](#) of this section indicates that the recipient has not met the Section 3 benchmarks described in [§ 75.23](#), the recipient must report in a form prescribed by HUD on the qualitative nature of its activities and those its contractors and subcontractors pursued. Such qualitative efforts may, for example, include but are not limited to the following:

(1) Engaged in outreach efforts to generate job applicants who are Targeted Section 3 workers.

(2) Provided training or apprenticeship opportunities.

(3) Provided technical assistance to help Section 3 workers compete for jobs (e.g., resume assistance, coaching).

(4) Provided or connected Section 3 workers with assistance in seeking employment including: drafting resumes, preparing for interviews, and finding job opportunities connecting residents to job placement services.

(5) Held one or more job fairs.

(6) Provided or referred Section 3 workers to services supporting work readiness and retention (e.g., work readiness activities, interview clothing, test fees, transportation, child care).

(7) Provided assistance to apply for/or attend community college, a four-year educational institution, or vocational/technical training.

(8) Assisted Section 3 workers to obtain financial literacy training and/or coaching.

(9) Engaged in outreach efforts to identify and secure bids from Section 3 business concerns.

(10) Provided technical assistance to help Section 3 business concerns understand and bid on contracts.

(11) Divided contracts into smaller jobs to facilitate participation by Section 3 business concerns.

(12) Provided bonding assistance, guaranties, or other efforts to support viable bids from Section 3 business concerns.

(13) Promoted use of business registries designed to create opportunities for disadvantaged and small businesses.

(14) Outreach, engagement, or referrals with the state one-stop system as defined in Section 121(e)(2) of the Workforce Innovation and Opportunity Act.

(c) **Reporting frequency.** Unless otherwise provided, recipients must report annually to HUD under [paragraph \(a\)](#) of this section, and, where required, under [paragraph \(b\)](#) of this section, on all projects completed within the reporting year in a manner consistent with reporting requirements for the applicable HUD program.

STATE OF ILLINOIS

City of Evanston

CONTRACT SPECIFICATIONS

For

2022 CDBG Sidewalk Improvements and Gap Infill

Bid Number: 22-27

CITY OF EVANSTON

SPECIAL PROVISIONS

2022 CDBG Sidewalk Improvements and Gap Infill

Bid Number: 22-27

TABLE OF CONTENTS

PROJECT DESCRIPTION 4

COMPLETION DATES 4

MATERIAL TESTING/INSPECTION 4

DEFINITION OF TERMS 4

ADVERTISEMENT, BIDDING, AWARD AND CONTRACT EXECUTION 6

SCOPE OF WORK 7

CONTROL OF WORK 7

CONTROL OF MATERIALS 10

LEGAL RELATIONS AND RESPONSIBILITY TO PUBLIC 11

PROSECUTION AND PROGRESS 18

MEASUREMENT AND PAYMENT 20

SUBMITTALS 23

SAW CUTS 27

FIBER OPTIC UTILITIES 28

CLEARING, TREE REMOVAL AND PROTECTION, CARE AND REPAIR OF EXISTING
PLANT MATERIALS 28

DISPOSAL OF EXCAVATED MATERIAL 32

TOPSOIL FURNISH AND PLACE 33

SODDING,SALT TOLERANT 33

AGGREGATE BASE COURSE 34

INCIDENTAL HOT-MIX ASPHALT SURFACING 34

PORTLAND CEMENT CONCRETE DRIVEWAY PAVEMENT 35

PORTLAND CEMENT CONCRETE SIDEWALK 36

BRICK PAVER REMOVAL AND REPLACEMENT 37

HOT-MIX ASPHALT SURFACE REMOVAL 37

CONCRETE GUTTER, CURB, MEDIAN, AND PAVED DITCH 38

CONSTRUCTION LAYOUT AND STAKING 39

STREET SWEEPING	40
TRAFFIC CONTROL AND PROTECTION.....	40
ENVIRONMENTAL CONTROL.....	40
CHAIN LINK FENCE.....	41

CITY OF EVANSTON

SPECIAL PROVISIONS

The following Special Provisions supplement the “Standard Specifications for Road and Bridge Construction”, Adopted January 1, 2022, (herein after called “the Standard Specifications”), the latest edition of the “Watershed Management Ordinance” of the Metropolitan Water Reclamation District of Greater Chicago, the latest edition of the Standard Specifications for Water and Sewer Construction in Illinois, the latest edition of the “Manual of Uniform Traffic Control Devices for Streets and Highways”, and the “Manual of Test Procedures of Materials” in effect on the date of invitation of bids, and the Supplemental Specifications and Recurring Special Provisions indicated on the Check Sheet included herein which apply to the govern the construction of,

2022 CDBG Sidewalk Improvements and Gap Infill **Bid Number: 22-27**

and in case of conflict with any part, or parts, of said Specifications, the said Special Provisions shall take precedence and shall govern.

PROJECT DESCRIPTION

Work on this project includes all material, labor, equipment and services for removal, regrading, replacement and/or installation of sidewalk, parkway, and curb at various locations in the City of Evanston.

COMPLETION DATES

A contract is anticipated to be awarded by the City of Evanston on May 23, 2022. This contract has a substantial completion of **July 29, 2022** and a final completion date on **August 31, 2022**.

MATERIAL TESTING/INSPECTION

All materials incorporated in this Contract are to be inspected according to IDOT’s non-QC/QA programs per the Project Procedures Guidelines (PPG). The latest version is available on the IDOT website at: <http://www.idot.illinois.gov/Assets/uploads/files/Doing-Business/Manuals-Guides-&-Handbooks/Highways/Materials/PPG.pdf>.

- Q/C for PCC and HMA incorporated into the project will be provided by the City.

All material incorporated into the work shall originate from IDOT approved sources (as required by PPG) and/or be accompanied by sufficient IDOT approved evidence of material inspection. All mix designs for PCC and HMA shall be submitted to the Engineer for review and approval.

DEFINITION OF TERMS

Add the following sentences to Article 101.16:

“The Engineer will have the rights and authority assigned in the Contract Documents in connection with completion of the Work in accordance with the Contract Documents.”

Add the following sentence to Article 101.28:

“The terms ‘Plans’ and ‘Drawings’ have like meaning and are used interchangeably in the Contract Documents.”

Add the following sentence to Article 101.29:

“The terms ‘Proposal’ and ‘Bid’ have like meaning and are used interchangeably in the Contract Documents.”

Add the following sentence to Article 101.30:

“The terms ‘Proposal Guaranty’ and ‘Bid Bond’ have like meaning and are used interchangeably in the Contract Documents.”

Add Article 101.56, which shall read as follows:

“**101.56 Addenda.** Written or graphic instruments issued prior to the execution of the Agreement which modify or interpret the Contract Documents, Drawings, and Specifications, by additions, deletions, clarifications or corrections.”

Add Article 101.57, which shall read as follows:

“**101.57 Award Authority.** The terms ‘State, Department, Council, City, Village, Owner, Municipality’ or other words used to describe the Awarding Authority in these documents and the Specifications shall be interpreted to mean the City of Evanston.”

Add Article 101.58, which shall read as follows:

“**101.58 Bonds.** Bid, Performance, and Payment Bonds and other instruments of security, furnished by the Contractor and his surety in accordance with the Contract Documents.”

Add Article 101.59, which shall read as follows:

“**101.59 Change Order.** A written order to the CONTRACTOR authorizing an addition, deletion or revision in the WORK within the general scope of the CONTRACT DOCUMENTS, or authorizing an adjustment in the CONTRACT PRICE OR CONTRACT TIME.”

Add Article 101.60, which shall read as follows:

“**101.60 Contract Price.** The total monies payable to the CONTRACTOR under the terms and conditions of the CONTRACT DOCUMENTS.”

Add Article 101.61, which shall read as follows:

“**101.61 Drawings.** The part of the CONTRACT DOCUMENTS which show the characteristics and scope of the WORK to be performed and which have been prepared by or approved by the ENGINEER.”

Add Article 101.63, which shall read as follows:

“**101.63 Purchase Order.** Written communication issued by the OWNER to the CONTRACTOR authorizing him to proceed with the WORK and establishing the date of commencement of the WORK.”

Add Article 101.64, which shall read as follows:

“**101.64 Project.** The undertaking to be performed as provided in the CONTRACT DOCUMENTS.”

Add Article 101.65, which shall read as follows:

“**101.65 Shop Drawings.** All drawings, diagrams, illustrations, brochures, schedules and other data which are prepared by the CONTRACTOR, a SUBCONTRACTOR, manufacturer, SUPPLIER or distributor, which illustrate how specific portions of the WORK shall be fabricated or installed.”

Add Article 101.66, which shall read as follows:

“101.66 Substantial Completion. That date as certified by the Engineer when the construction of the Project is sufficiently completed, in accordance with the Contract Documents, so that the Project can be utilized for the purposes for which it is intended. For this project, substantial completion shall be accomplished when all work is completed except placement of sod and punch list items.

Add Article 101.67, which shall read as follows:

“101.67 Supplemental Standard Specifications. Modifications to the Standard Specifications.”

Add Article 101.68, which shall read as follows:

“101.68 Supplier. Any person or organization who supplies materials or equipment for the Work, including that fabricated to a special design, but who does not perform labor at the site.”

Add Article 101.69, which shall read as follows:

“101.69 Written Notice. Any notice to any party of the Agreement relative to any part of the Agreement in writing and considered delivered and the service thereof completed, when posted by certified or registered mail to the said party at his last given address, or delivered in person to said party or his authorized representative on the Work.”

ADVERTISEMENT, BIDDING, AWARD AND CONTRACT EXECUTION

Delete Article 102.01 and replace it with the following:

“102.01 Procedures to be in Accordance with Rules. The procedures for the advertisement, bidding, award and contract execution shall be in accordance with these Specifications.”

Add Article 102.02, which shall read as follows:

“102.02 Examination of Site. There is no warranty or guaranty, either expressed or implied, that the provided subsurface information will disclose the actual conditions which will be encountered during the progress of the Work. Bidders shall examine the site, interpret or disregard subsurface information as they see fit, and arrive at their own conclusions regarding the nature, character, quality, and quantity of subsurface conditions likely to be encountered. By submitting their Bids, Bidders attest that they have fully complied with these requirements and made their own conclusions regarding subsurface conditions, which are reflected in their Bids. Bidders further attest that, should they be awarded construction Contract(s) for the Project, they shall neither have nor assert against the Owner or Engineer any claims for damages, for extra work, or for relief from any obligation of this Contract based upon deficiencies in the subsurface information provided or failure by the Owner to furnish other subsurface information or knowledge in Owner's or Engineer's possession, if any.

Bidders will be permitted to make test borings, test pits, soundings, or other investigations on the site of the Work which they so desire subject to approval by the Owner. Bidders wishing to make such investigations shall coordinate the intended site investigations with Mr. Chris Venatta, Senior Project Manager, Capital Planning and Engineering Bureau, Public Works Agency, City of Evanston; forty-eight (48) hours' notice prior to the intended investigation will be required. Bidders shall be responsible for coordination with JULIE and other utility companies, and shall be required to have an insurance coverage as indicated in the specifications with the Owner and Engineer as additional insured on a non-contributory basis. It shall be understood that the party or parties receiving such approval shall assume all risks and liability contingent thereto, and shall be responsible for restoring the site to its original condition before the investigation, including site clean-up.”

SCOPE OF WORK

Delete Article 104.04 and replace it with the following:

“104.04 Maintenance of Detours. Maintenance of Detours that may be required in the Work shall be performed by the Contractor. Work shall be performed in accordance with Section 107 of the Standard Specifications and as modified by the Special Provisions. The Owner must approve all detours and road closures. Such approval will not be unreasonably withheld, but all requests must be submitted with supporting data such as the projected duration of the closure and detour routes. The Owner may require the use of signage with specific street names identifying the detour route.”

Delete Article 104.05 in its entirety.

Add Article 104.08, which shall read as follows:

“104.08 Intent of Plans and Specifications. Any minor work not specifically mentioned in the Specifications or not shown on the Plans, but necessary for the proper completion of the Work shall be considered as being a part of and included in the Contract and shall be executed in the proper manner, and the Contractor shall not be entitled to extra or additional compensation for the same. The Work quantities listed on the Bid Schedule, Drawings, Attachment A Schedule and elsewhere in the Contract Documents are approximate and are intended for comparison of Bids only and do not constitute a "guaranty" of the amount of Work to be performed. Actual Work quantities may vary significantly. Payment shall be made only for the amount of each Payment Item quantity actually installed. Measurement and payment for Work shall be in accordance with the Standard Specifications as modified herein by Special Provision. The price Bid for each Payment Item shall include all work required to complete the Item including a proportionate allocation of Contractor overhead and profit, and shall not include costs more properly allocated to other Payment Items.”

Add Article 104.09, which shall read as follows:

“104.09 Record Plans (Record Drawings). The Contractor shall keep a complete up-to-date record of the actual construction of the Work in accordance with the special provision for Submittals.”

CONTROL OF WORK

Add the following paragraph to Article 105.01

“The Engineer shall have no authority to suspend the Work, wholly or in part, for any reason. All rights conferred onto the Engineer for suspending the Work by Standard Specification Articles 105.01 and 108.07 shall be the sole right of the Owner.”

Delete Article 105.05 and replace with the following:

“The documents forming the Contract Documents, as listed in the Agreement, are complementary, and the work called for by one is as binding upon the parties as if it was called for by all. In the event of conflict between the Contract Documents, the interpretation of the Engineer shall govern. Generally, the Engineer will resolve conflicts in a manner which will yield the greater quality in the Work. In the interpretation of any conflict between the Contract Documents, the following order of precedence shall govern:

- Evanston General Conditions
- Bid Form
- Addenda

- Instruction to Bidders
- Special Provisions
- Drawings/Plans
- Standard Specifications – Illinois Department of Transportation
- Other Referenced Specifications
- Other documents included in the Contract Documents by specific reference in the Agreement.”

Delete the first paragraph of Article 105.06 and replace it with the following:

“The Contractor will be furnished, free of charge, 2 full-size sets of Drawings, and 2 sets of the Contract Documents. Any additional full size sets or random sheets will be furnished at a cost of \$3.00 per drawing sheet and \$0.50 per Contract Document sheet. The IDOT Standard Specifications will not be furnished and the Contractor shall obtain those specifications on his own directly from IDOT.”

Add the following paragraphs to Article 105.06:

“On or within fifteen (15) calendar days from the date on the Purchase Order, the Contractor shall identify the person who will act as Project Superintendent in writing to the OWNER. The Project Superintendent is required to attend monthly meetings to discuss the Project status.”

Add the following sentences to the first paragraph of Article 105.07:

“The Drawings depict the locations of various existing underground utilities, including gas mains, electric duct lines, telephone lines, cable TV lines, sewers, and water mains. The information shown on the Drawings has been determined from the best available information, including field surveys and/or the records of the parent utility companies. Such information may or may not be accurate. Other underground utilities may also be present. As such, the Owner and Engineer assume no responsibility in the event that, during construction, utilities other than those shown are encountered or that actual locations of those utilities shown are different from the locations designated on the Drawings.

Delete Article 105.09 of the Standard Specifications and replace it with the following:

“105.09 Survey Control Points. The primary vertical and horizontal control points for the Work are shown on the Drawings. Using this reference control, the Contractor shall take the necessary topography, locate all earthwork and structures, and establish all grades necessary for the accomplishment of the Work. The Contractor shall carefully preserve all marks, reference points and stakes established, and, in the case of their destruction, such points, marks or stakes shall be replaced by the Contractor at his expense. The Contractor shall also be responsible for any mistakes caused by their loss or disturbance.

Any monuments that are disturbed by construction operations shall be reset by the Contractor in accordance with generally accepted engineering and surveying practice. Property corners, fences, or any other indications of property lines shall be referenced by the Contractor prior to construction and reset by the Contractor after completion of construction in accordance with generally accepted engineering and surveying practice.

Prior to establishing the working control, the Contractor shall provide, at the Engineer's request, sufficient copies of an illustration of the working control relative to pertinent construction. The Engineer will check all forms prior to placing concrete. All checking by the Engineer will be

independent. The sole intent of the Engineer's checking of working controls, forms and other references shall be to provide greater assurance to the Owner that the Work, when completed, will be in General conformance with the Contract Documents. The Contractor shall be solely responsible for the correctness and adequacy of Work controls.”

Delete Article 105.10 and replace it with the following:

“105.10 Authority of Engineer. The Engineer, as the Owner's representative, will administer the Contract and observe, survey, monitor, and judge the performance of the Contractor. The Engineer will perform technical inspections of work performed by the Contractor and shall have authority to reject, in writing, all work and materials which do not comply with the Contract Documents.

The Engineer, as the Owner's representative, will interpret the Contract Documents. The Engineer will decide questions which arise in the execution of the Work or in the interpretation of the Contract Documents. The Engineer's decision or interpretations shall be final, unless the Contractor appeals to the Owner in writing within fifteen (15) calendar days after the decision or interpretation.

Neither the Engineer's authority to act under this Section, or elsewhere in the Contract Documents, nor any decision made by the Engineer in good faith either to exercise or not exercise such authority shall give rise to any duty or responsibility of the Engineer to the Contractor; any Subcontractor; any supplier, manufacturer, fabricator, distributor, vendor, or any other person or organization performing any of the Work, or to any surety for any of them.

The use of terms, such as, but not limited to: “approval”, “judgment”, “requirement”, or “direction” shall not be effective to assign to the Engineer any duty or authority to supervise or direct the furnishing or performance of the Work or any duty or authority to undertake responsibility contrary to the provisions herein; shall not be construed in any manner to relieve the Contractor of any of its responsibilities under the Contract Documents; nor, shall be construed to create duties on the part of the Engineer or the Owner toward the Contractor.

The Engineer will not be responsible for the Contractor's means, methods, techniques, sequences, or procedures of construction, or the safety precautions and programs incident thereto, and the Engineer will not be responsible for the Contractor's failure to perform or furnish the Work in accordance with the Contract Documents.

The Engineer will not be responsible for the acts or omissions of the Contractor or of any Subcontractor; any supplier, manufacturer, fabricator, distributor, vendor, or of any other person or organization performing or furnishing any of the Work. It is agreed and understood that the Contractor is solely responsible for supervising the Work and for safety at the site of the Work as provided for in Article 105.14.”

Delete Article 105.11 in its entirety.

Add the following paragraph to Article 105.12:

“The Contractor agrees that representatives of the Owner, Engineer, Illinois Environmental Protection Agency, and the Metropolitan Water Reclamation District of Greater Chicago shall have access to the Work whenever it is in preparation or progress and that the Contractor shall provide facilities for access and inspection.”

Add Article 105.14, which shall read as follows:

“105.14 Job-Site Safety. The Contractor is solely responsible at all times for safety at the job site.

The Contractor shall implement whatever protection measures are necessary to fully protect his work forces, the work forces of his suppliers and subcontractors, and the general public from construction activities. Any and all safety regulations and other provisions of applicable Federal, State and local laws and building and construction codes shall be observed.

The Drawings do not include standards or guidelines for construction safety. The Contractor shall be responsible for the adequacy and safety of all construction methods and the safe prosecution of the Work, including, but not limited to: forms, falsework, scaffolding, trench protection, protective barricades, protective rails, and warning lights. It is expressly stipulated that any examination and/or approval by the Engineer of the Contractor's plans for such items as well as for any other items needed for the prosecution of the Work will cover only general conformance with the design concept of the project and general compliance with the information given in the Contract Documents. Such examination and/or approval by the Engineer shall not relieve the Contractor from full and complete responsibility for safe prosecution of the Work at all times and for obtaining satisfactory results. Requirements for safety-related work tasks presented in Project Drawings and Specifications, such as traffic control, represent the minimum level of protection which must be implemented. Depending on the Contractor's means and methods, these protection measures may or may not be fully adequate to protect Project work forces or the general public. As such, the Contractor is solely responsible for and is required to implement whatever additional protection measures may be necessary to fully protect the Project work force and the general public.

Nothing in the foregoing paragraphs shall be construed as relieving the Contractor from full responsibility for safe prosecution of the Work at all times. In the event the Owner, Engineer or their representatives are held by a court or administrative body to be liable for personal injuries or damages to property arising from deficiencies in job-site safety, the Contractor shall promptly indemnify and hold them harmless there from."

Add the following Article 105.15, which shall read as follows:

"105.15 Official Contact. All official notices required to be delivered to the City of Evanston under the terms of this Contract shall be sent to the following representative of the City:

Mr. Chris Venatta, Senior Project Manager
Capital Planning & Engineering Bureau, Public Works Agency
City of Evanston
2100 Ridge Avenue,
Evanston, IL 60201
(847) 866-2967

CONTROL OF MATERIALS

Add the following to Article 106.03:

"106.03 Samples, Tests, Cited Specifications

(a) General

The City will provide the services of an independent testing laboratory to perform the testing required by the specifications for soils, backfill, aggregates, concrete, and asphalt or concrete paving. All costs associated to testing will be paid for by the City of Evanston. Raw materials testing shall be performed sufficiently in advance of delivery to the job site to permit the Engineer to review test results. Use of materials prior to Engineer's review of raw material test results shall be at Contractors sole risk. Materials thus used and later found not to be in conformance with the

Contract documents shall be removed and replaced by the Contractor at his own expense. Tests of material placement effectiveness, such as backfill compaction density, shall begin as soon as practical after initial material installation.

i. Contractor's Responsibilities

a. Notify Engineer at least 48 hours in advance of time and place of tests to be made at point of manufacture, assembly, or fabrication to permit Engineer to witness tests if he so desires.

LEGAL RELATIONS AND RESPONSIBILITY TO PUBLIC

Delete the first paragraph of Article 107.04 and replace it with the following:

“Owner will obtain approvals of the construction plans from the Metropolitan Water Reclamation District of Greater Chicago (MWRD or MWRDGC) and the Illinois Environmental Protection Agency (IEPA). The Contractor shall at his own expense obtain all required construction permits, licenses, insurance, and other appurtenant approvals or permissions for the execution of this Work; give all necessary notices; pay all fees required; fulfill all permit requirements, including construction standards, bond requirements, and insurance requirements; and, comply with all rules, regulations, ordinances, and laws relating to the Work and to the preservation of public health and safety.”

Add the following sentences to Article 107.08:

“Suitable toilet facilities shall be provided at the job site. The facilities and the location of same shall be approved by the Owner and shall be kept in a clean and sanitary condition. Sanitary sewer manholes or construction trenches may not be used for toilet facilities.”

Delete the first sentence of Article 107.09 and replace it with the following:

“The Contractor shall notify the Engineer at least thirty (30) days in advance of the starting of any construction work which might in any way inconvenience or endanger traffic, so arrangements can be made, if necessary, for closing the road and providing suitable detours.”

Add the following paragraphs to Article 107.09:

“The Contractor shall identify and obtain, at their own expense, other sites for storage of materials and equipment. Sites shall be approved by the Owner and shall conform to City zoning and land use regulations.

Contractors shall confine all work activities to the public right-of-ways, except areas designated as tree protection zones. If, for their convenience, Contractors wish to conduct work activities outside public right-of-ways, including storage of equipment and materials, Contractors shall obtain written permission from affected property owners prior to proceeding with these work activities. Costs of obtaining permission, permits, easements, site preparation, site maintenance, site restoration, and all other expenses associated with work outside right-of-ways and easements shall be borne by the Contractors at no additional expense to the Owner.

Construction materials may not be placed or stored along City streets and other public areas more than five (5) calendar days prior to their planned incorporation into the Project. Excess materials to be incorporated into the Project, including pipe, backfill materials, and other construction materials, not incorporated into the Project shall be removed from the construction site by the end of each day and shall be disposed of in accordance with these Specifications. Temporary storage of materials shall not interfere with curb line storm drainage. Reclaimed construction materials shall

be moved to the Contractor's storage areas. Excess spoils shall be removed at the end of each day.

Excess construction equipment not actively engaged in daily work operations shall be stored only in the Contractor's storage areas and not along City streets. Tracked construction equipment shall be moved from place to place in the City only on rubber-tired trailers. "Walking" of tracked equipment between construction areas is expressly prohibited. Refueling trucks shall not be parked on City streets and shall be returned to the Contractor's storage area when not in use. The Contractor shall provide off-street parking for personal vehicles belonging to his employees, supplier's employees, and subcontractor's employees. These vehicles may not be parked along City streets or in Work areas. No trailers and/or connex containers will be allowed to be stored on/in the City of Evanston R.O.W.

Electrical power for construction operations outside normal project hours shall be obtained through temporary power drops from Commonwealth Edison facilities. The Contractor shall not use engine-driven generators for power at work sites or use other engine-driven equipment outside normal project work hours, including, but not limited to: pumps and compressors, except in emergency situations.

The Contractor shall provide receptacles as necessary at construction areas for depositing waste paper and garbage; and, shall empty these receptacles regularly. The Contractor shall keep the construction site and his storage sites neat and shall promptly clean up any debris that accumulates. All waste materials shall be hauled to a legal waste disposal site of the Contractor's choice.

The Contractor shall conduct his operations so that access to homes and other buildings is maintained at all times when Contractor is not working at that specific location. The Contractor shall cooperate in efforts to notify home and other building owners as to when direct vehicular access to their property will be curtailed and the approximate length of time of such curtailment. Written and/or vocal notification shall be given to affected residents or tenants of the properties not less than 24 hours prior to access curtailment. The Contractor shall maintain access for emergency vehicles to all parts of the construction area at all times.

Where water service connections are made, the Contractor shall not place spoil on the parkway.

The Contractor shall provide for and maintain the flow in all sewers, drains, building or inlet connections and all water-courses which may be met with during the progress of the Work. He shall not allow the contents of any sewer, drain, or inlet connection to flow into trenches, sewers, or other structures to be constructed under the Contract and shall immediately remove and cart away from the vicinity of the Work all offensive matter. The Contractor shall not disrupt the function of individual sanitary services for more than four continuous hours. If construction operations are anticipated to disrupt individual services for more than four hours, the Contractor shall provide for temporary sanitary service for the duration of the disruption.

The Contractor shall promptly notify the proper utility company and all other effected parties of any damage to water, gas, electric, telephone, sewer, and other utility lines and connections caused by the Contractor's operations. The damage shall be immediately repaired at the Contractor's expense. In the case of an accidental breaking of a water main or service line, the repairs of such a break shall have priority over all other operations. The parties whose services are affected by the break shall be notified at once and all assistance given to supply emergency water where necessary by temporary lines, tank truck, or other means. The Contractor shall maintain an

appropriate inventory of the materials for emergency repairs. In the case of an accidental breakage of a street light cable, the Contractor shall submit for approval a licensed electrical contractor to repair any and all damage to the existing street light cables.

The Contractor shall not allow travel upon any street, park, roadway, or alley to be hindered or inconvenienced needlessly, nor shall the same be wholly obstructed without the written permission of the Owner thereof. No construction vehicles shall be driven through or shall be parked in alleys unless so approved by the Engineer. Construction traffic shall be routed on major City through-streets. Construction traffic on minor streets shall be limited as much as is practical. All street closures must be approved by Engineer.

When traffic must be obstructed, the Contractor shall provide proper traffic control as accepted by the Engineer and Owner by placing clearly worded signs announcing such fact with proper barricades, at the nearest cross-streets on each side of such obstructed portion, where travel can pass around the obstruction in the shortest and easiest way. "No parking" signs must be approved by the Engineer and must be POSTED AND DATED at least 48 hours before the intended date of use. "No Parking" signs are to be purchased from the Owner. If vehicles are still parked in "No Parking" areas identified by the Contractor, the Contractor shall notify the Engineer who will contact the Evanston Police to have the vehicles towed away. No towing of vehicles shall be done by the Contractor.

Driveways to fire department buildings, driveways to medical buildings, and driveways to businesses required for continuance of their commerce shall be kept open and maintained in passable conditions at all times unless modified by agreement between the Contractor and the property owner. All agreements between the Contractor and private property owners must be in writing to be considered binding. The Contractor shall give reasonable notice to the owners of all private driveways before interfering with them. Daily construction operations shall be terminated at such locations that the operations of driveways are not obstructed. Driveways shall be passable between the hours of 6:00 p.m. and 9:00 am.

Delete Article 107.17 and replace it with the following:

"107.17 Use of Explosives

(a) General

Blasting and other uses of explosives will not be permitted under this Contract."

Delete Article 107.18 and replace it with the following:

"107.18 Use of Fire Hydrants. If the Contractor desires to use water from hydrants, he shall fill out an application to the City of Evanston Utilities Department and shall conform to the municipal ordinances, rules, or regulations concerning their use. The Contractor shall obtain a use permit for each hydrant, and shall operate the hydrant properly. The Contractor is required to use an RPZ or appropriate back flow prevention device subject to approval of the City. There is a \$300 deposit on the fire hydrant and all borrowed equipment. Water shall be furnished from hydrants at no cost to the Contractor. However, the Contractor shall restore any damage to the hydrant caused by his use, including settlement.

Fire hydrants shall be accessible at all times to the Fire Department. No material or other obstructions shall be placed closer to a fire hydrant than permitted by municipal ordinances, rules or regulations, or within five (5) feet of a fire hydrant, in the absence of such ordinances, rules or regulations."

Add the following paragraphs to Article 107.20:

“All existing roadway ditches or swales disturbed during construction operations shall be restored to their original cross-section and longitudinal grade, as approved by the Engineer. Any settlement caused by sewer or water main trenches shall be refilled and the original grades maintained by the Contractor for a period of one year from the date of final completion of the Project. Any property damage caused by trench excavation or augering operations, including settlement, shall be restored at Contractor's expense.”

Existing roadways, driveways, sidewalks, curbs, utilities, structures, landscaping, site objects, and other site improvements not indicated to be removed and/or replaced as part of the Project which are damaged by Contractor's operations shall be repaired to a condition equal or better than that prior to the start of construction; or, if deemed un-repairable by the Owner, removed and replaced by the Contractor at no cost to the Owner in accordance with the terms of the Project specifications, Drawings, applicable codes, ordinances, and technical standards.

The correction of defects in the Work performed by the Contractor shall be done at no additional cost to the Owner and in accordance with the terms of the Project specifications, Drawings, applicable codes, ordinances, and technical standards.

Add the following paragraph to Article 107.25:

“Prior to commencement of construction operations, the Contractor shall prepare a written inventory of existing traffic control and other signage along the routes of construction. This inventory shall list the location, wording, and general condition of signage. This inventory shall be submitted to the Engineer upon completion and before any signage is removed for construction activities. The Contractor shall remove all existing traffic control signs, store these signs in a manner, which prevents damage, and reinstall them as soon as possible following installation of new sewers as coordinated by the Engineer.”

Delete Article 107.27 and replace it with the following:

Extension of Indemnification to Third Parties. In the event that some of the Work is to be completed on property that is not owned by the Owner, the Contractor shall provide the indemnification and save harmless protection to the owner of such property. The Contractor shall also provide the indemnification and save harmless protection to owners of adjacent properties that may be affected by his operations.

Claims and disputes by third parties arising from work on this Contract, including augering and directional drilling or excavation work shall be resolved in accordance with the procedures hereinafter specified. This provision does not change, modify or alter the Contractor's responsibility to follow the insurance requirements of the Contract. Neither does this provision change, modify or alter the Contractor's responsibility to defend, indemnify and hold harmless the Owner and the Engineer from all types of claims that may arise out of or in consequence of the performance of this work by the Contractor or which may result in any way there from as that duty is stated in Section 107. Furthermore, this provision does not change, modify or alter the Contractor's responsibility to follow the provisions requiring a Contractor's Performance Bond.

The Contractor agrees to follow the procedure described following in resolving all property damage disputes that arise during the performance of the Work under the Contract. The Contractor agrees that the following procedure is the way the Contractor will hold the City of Evanston, MWRD and Engineer harmless for property damage claims:

i. Procedure for Resolving Property Damage Disputes

If the Contractor receives a claim for property damage allegedly caused by his performance of the Work under this Contract, the Contractor shall, within five (5) calendar days of receipt of such claims:

Acknowledge the claim to the property owner.

Send a copy of the said claim and acknowledgment to Engineer.

If the claim is not settled (or the Contractor does not agree to settle the claim) within five (5) calendar days, the Contractor shall:

Forward the claim to the Contractor's insurance carrier.

Require his insurance company to forward to Engineer an acknowledgment of receipt of the claim.

The Contractor and insurance carrier shall either settle or deny claims within sixty (60) calendar days of initial receipt of the claims. The insurance carrier and Contractor shall notify the Engineer of claims settled and denied, including the terms of the settlement or reasons for denial. The Contractor shall advise property owners of the decision to deny their claims and shall include in the Notice of Denial the name and address of the person authorized to accept service of process on behalf of the Contractor.

When a claim is allowed in any amount, Contractor shall, within thirty (30) calendar days of the award, pay to the property owner the amount of the award. If the Contractor does not make these payments to the property owner within the thirty (30) calendar day period, the Owner shall be authorized to make these payments for the Contractor and then deduct the amounts paid from the next payment due the Contractor under this Contract.”

Add the following paragraphs to Article 107.30:

“The Contractor assumes full responsibility for the safekeeping of all materials and equipment and for all unfinished work until final acceptance by the Owner, and if any of it is damaged or destroyed from any cause, the Contractor shall replace it at his own expense.

The Contractor shall indemnify and save harmless the Owner against any liens filed for nonpayment of his bills in connection with the Contract work. The Contractor shall furnish the Owner satisfactory evidence that all persons who have done work or furnished materials, equipment or service of any type under this Contract have been fully paid prior to the acceptance of the Work by the Owner.

The Contractor shall erect and maintain such barriers and lights and/or watchmen as will protect and warn pedestrians and vehicles, and prevent access of unauthorized persons to the site so as to prevent accidents as a consequence of his work.

The Contractor shall indemnify and hold harmless the Owner, the Owner's employees, the Engineer, and the Engineer's employees from any and all liability, loss, cost, damages and claims, and expense (including reasonable attorney's fees and court costs) resulting from, arising out of, or incurred by reason of any claims, actions, or suits based upon or alleging bodily injury, including death, or property damage arising out of, or resulting from the Contractor's operations under this Contract, whether such operations be by himself or by any subcontractor or by anyone directly or

indirectly employed by either of them. The Contractor shall obtain insurance for this purpose, which shall insure the interests of the Owner and Engineer as the same may appear, and shall file with the Owner and Engineer certificates of such insurance.

The Contractor shall protect the Owner's property and adjacent property from injury or loss resulting from his operations. Objects sustaining such damage shall be replaced to the satisfaction of the Owner and Engineer; the cost of such repairs shall be borne by the Contractor.

The Contractor shall be completely responsible for protecting his work from vandalism. Any vandalized concrete shall be repaired and/or replaced as directed by the Engineer and at the Contractor's expense.”

Delete the second and fourth paragraphs of Article 107.35.

Delete Article 107.40 in its entirety and replace with the following:

Unknown Utilities. The requirements stated in Article 107.37 for known utilities shall apply to unknown utilities. No additional compensation will be allowed for any delays, inconveniences, or damages sustained by the Contractor due to the presence of any claimed interference from unknown utility facilities or any adjustment of them, except as specifically provided in the contract.

Definition. An unknown utility is defined as an active or inactive underground transmission facility (excluding service connections) which is either:

(1) Located underground and (a) not shown in any way in any location on the plans; (b) not identified in writing by the City to the Contractor prior to the letting; or (c) not located relative to the location shown in the contract within the tolerances provided in 220 ILCS 50/2.8 or Administrative Code Title 92 Part 530.40(c).

(2) Located above ground or underground and not relocated as provided in the contract

Add Article 107.42, which shall read as follows:

“107.42 Traffic Control and Protection. Special attention is called to the following Highway Standard Details and Section 701 relating to Traffic control:

STANDARDS

701301, 701501, 701602, 701606, 701611, 701701, 701801, 701901, 780001

If requested by Contractor, one-block-long road closures will be allowed by the Owner in areas deemed necessary by the Engineer. No more than one lane of other streets may be closed at any time. Traffic control shall be in accordance with the applicable sections of the Standard Specifications, the applicable guidelines contained in the Illinois Manual on Uniform Traffic Control Devices for Streets and Highways, any Special Provisions, any Supplemental Standard Specifications and any special details and Highway Standards contained herein.

At the Pre-Construction Meeting, the Contractor shall furnish the name, and a 24-hour telephone number of the individual in his direct employ, who is responsible for the installation and maintenance of the traffic control for the Project. In accordance with Article 108.01, if a subcontractor is to provide this aspect of the work, consent of the Engineer is required. This shall not relieve the Contractor of the foregoing requirement for an individual in his direct employ to superintend the implementation and maintenance of the traffic control.

The Contractor shall furnish, install, maintain, relocate, and remove all traffic cones, signs,

barricades, warning lights and other devices which are to be used for the purpose of controlling pedestrian and vehicular traffic. The traffic control requirements presented in the Contract documents represent the minimum level of control which shall be provided. The Contractor is solely responsible for implementing all other traffic control measures required to fully protect pedestrians, vehicles, and his work forces.

The Contractor is responsible to ensure that all barricades, warning signs, lights and other devices installed for traffic control are in place and operational twenty-four hours each calendar day this Contract is in effect. In particular, the Contractor shall make sure that warning lights are functioning during night-time hours. Warning lights shall be checked each calendar day to verify functioning, replace batteries/bulbs, and/or replace light assemblies as necessary.

All areas of work shall be protected each night by Type II drum-type or sawhorse-type barricades at not greater than fifty (50) foot centers.

Drum-type and sawhorse barricades shall be equipped with working flashing lights and highly visible reflectors, reflective tape or reflective paint. At least six reflectors shall be visible from any viewing angle. Tape or paint shall cover at least 30 percent of the barricade from any viewing angle and shall conform to Section 700 of the Standard Specifications. Arrow boards shall be silent type powered by electricity or battery packs. No engine/generator-powered arrow boards are permitted.

The Contractor shall place "No Parking" signs a minimum of two (2) calendar days prior to curb replacement, patching or resurfacing operations. All "No Parking" signs must have the approval of, affixed, and displayed to the satisfaction of the Engineer. Posting of signs on trees shall be done in such a manner to facilitate removal; stapling or nailing of signs to trees is prohibited. Contractor shall keep a log of all posted "No Parking" signs and shall submit the log to the Engineer promptly upon request.

School busses and emergency vehicles shall have access to all premises at all times."

Add Article 107.43, which shall read as follows:

"107.43 Maintenance of Roads. Contractor shall maintain roads for all weather conditions and at all times in compliance with state and local regulations. Upon completion of construction, Contractor shall return all roads to their original condition as described in Section 442. With the Owner's approval, roadways and drives may be closed temporarily in the immediate area of the work. However, roadways and driveways shall be reopened as soon as is practical following the completion of installation and/or restoration. All roadways shall be maintained open to local traffic between the hours of 6:00 p.m. and 9:00 am or at other times when Contractor is not actively engaged in sewer and/or water main installation. Roadways shall be open to through traffic whenever practical. Roadways shall be open to emergency vehicles at all times. Contractor shall promptly remove all loose material spilled on roadways during the execution of the Work.

Temporary pavements shall consist of aggregate, cold mix, hot mix, or steel plates as specified or as directed by the Engineer. Hot mix shall be used for all IDOT and arterial streets and all intersections, and shall be compacted to the satisfaction of the Engineer by a steel drum roller. Aggregate surface course shall be used for other streets, alleys and driveways, unless otherwise directed by the Engineer. Steel plates shall be used to close construction work shafts and shall be set with their surfaces flush with existing roadways.

Add Article 107.44, which shall read as follows:

“107.44 Water Control. The Contractor shall perform grading and other operations to maintain site drainage. Surface water shall not be allowed to accumulate in excavations. The Contractor shall dispose of surface and subsurface water in a legal manner. He shall not allow mud, silt, or debris to flow into any surface water area or body other than in compliance with the State Water Quality Standards. Where the Contractor's operations disturb existing combined sewers, the Contractor shall provide temporary bulkheads and pumping facilities as necessary to maintain the combined sewers, connected building services and storm water inlet leads in full operation, including transport of the maximum dry-weather and wet-weather flow of which the existing sewer is capable. Combined wastewater shall not be permitted to flow along streets, public right-of-ways, private property, trench areas or inactive relief sewers. All earthworks, moving of equipment, water control of excavations, and other operations likely to create silting, shall be conducted so as to minimize pollution to watercourses or water storage areas. Under no circumstances shall the Contractor discharge pollutants into any watercourse or water storage area.”

Add Article 107.45, which shall read as follows:

“107.45 Overnight Protection of Work. The Contractor shall adequately backfill, cover with appropriate plates, or suitably fence and barricade all open excavations at the completion of each day's work. Open-cut excavations shall be reduced to a maximum length of thirty feet overnight. Excavations shall not block roadways or driveways. Open ends of sewers being installed shall be bulk-headed overnight with watertight plugs to prevent entrance of soils, entrance of groundwater, and/or entrance by the public. The Contractor shall protect all excavations from public access. All shafts for open-cut work shall be fully covered during non-working hours and during working hours when not being actively used for that day's construction.”

Add Article 107.46, which shall read as follows:

“107.46 Guarantees and Warranties. All guarantees and warranties required shall be furnished by the Contractor and shall be delivered to the Owner before the final voucher on the Contract is issued.”

PROSECUTION AND PROGRESS

Add the following to Article 108.01:

“The Owner may approve the use of second tier subcontractors on a case by case basis after the Prime Contractor initiates a request for approval of same. The Prime Contractor is responsible for compliance with all the provision of the contract and is also responsible for providing that all of the pertinent provisions and requirements of the prime contract are incorporated into the second tier subcontracts. The Prime Contractor shall provide a copy of the second tier subcontract, second tier subcontractor insurance certificates, and shall provide waivers from the second tier subcontractors as required for the processing of pay estimates. The second tier subcontractor shall not commence work until approval is granted by the Owner”

Add the following to Article 108.02:

“Prior to commencing construction operations, the Project Superintendent shall meet with the Owner and Engineer and submit his Progress Schedule.

The construction schedule shall reflect that no work will be performed on Saturdays, Sundays, Holidays, and the days listed below as modified in Art. 108.03 Section 108. Calendar day is defined as: “Any calendar day between April 1 and November 30 inclusive, except Saturdays, Sundays or legal holidays. If the City approves work on Saturday, the Contractor will not be charged a calendar day for work done on that Saturday.”

The Contractor shall submit to the Engineer monthly updates of the schedules required per these specifications. Schedule updates shall reflect the progress to date by providing actual start dates for activities started, actual finish dates for completed activities, and identifying out of sequence work, schedule logic changes, and any circumstances or events impacting the current schedule. The updates shall also contain the Contractor's best estimate of the remaining duration for activities not complete as of the date of the update. All graphic presentations and reports shall be submitted with the monthly partial payment requests.

The Contractor shall prepare and submit daily reports containing, among other items, the following information:

1. A description of work activities performed.
2. A description of obstructions encountered.
3. Temperature and weather conditions.

The reports shall be submitted on a daily basis, by the end of the next business day.

Information provided on the daily report shall not constitute notice of delay or any other notice required by the Contract Documents.

Failure to provide the updated schedule every month may be cause to withhold any partial payment due to the Contractor during the course of the Contract until the deficiency has been remedied."

Delete the second paragraph of Article 108.03 and replace it with the following:

"The Contractor shall notify the Owner and Engineer at least 72 hours before beginning work. The Contractor shall give a minimum of 24 hour notice, not including Saturdays, Sundays or legal holidays, prior to suspension of construction activities for any non-weather related reason. Suspension of work for non-weather related reasons must be pre-approved by the Engineer. The Contractor must be in advance of the Controlling Item as indicated by his submitted Construction Schedule as a condition of the Engineer's granting of authorization to suspend work. In addition, the suspension shall not affect the completion date of the Project. The Contractor shall notify the Engineer at least 24 hours, not including Saturdays, Sundays or legal holidays, prior to the resumption of work. The site must be left in a clean and neat manner, acceptable to the Engineer, prior to the authorization of the suspension.

The Contractor shall perform the Work in accordance with the following scheduling requirements:

- a. The Contractor will be required to discuss their operations and get verbal and / or written permission at least twenty-four (24) hours in advance in order to work on the following dates:

Monday, July 4, 2022

Independence Day

Delete Article 108.04 and replace it with the following:

"108.04 Normal Work Hours. Normal work hours shall be Monday through Friday (excluding legal holidays) between 7:00 am and 5:00 p.m. local time during the calendar dates specified in Article 108.03. Except for work required to maintain warning lights, barricades and other safety/health-related systems no work shall be performed on Saturdays, Sundays, legal holidays, or between 5:00 pm and 7:00 am on other days without specific permission of the Owner.

No work, except maintenance of warning lights, barricades and other safety/health-related systems, may be performed unless the Engineer is available to observe/inspect construction activities. Owner will provide the services of the Engineer as needed for construction observation/inspection between the hours of 7:00 am and 5:00 p.m., Monday through Friday, except legal holidays, in accordance with the calendar dates specified in Article 108.03. Prohibited work activities outside of normal work hours include but are not limited to the warming up of any piece of equipment or turning on engines. Any violation for working hours will incur a \$500.00 fine for each occurrence.

If at any time during the project the Contractor elects to work on a Saturday, they must obtain written permission from the Capital Planning and Engineering Bureau, Senior Project Manager and/or City Engineer/Bureau Chief, Public Works Agency. Contractor shall request this at least twenty-four hours in advance of Saturday work. The contractor is required to estimate any Saturday work and include that in the bid amount.

If at any time during the project the Contractor elects to work past the normal working hours, the Engineer shall invoice the Contractor for Engineering Services at a rate of \$75.00 per hour for Engineering Services provided beyond the normal working hours at the conclusion of each month. Engineering Services will be paid for at the contract unit price of \$75.00 per hour. Administrative accounts payable, overhead, and profits costs shall be included in the various contract items and no additional compensation will be allowed.

Delete Article 108.05 and replace it with the following:

“108.05 Project Completion Times:

The Project Completion Time and Substantial Completion Times shall be as specified in the Contract Documents. Liquidated damages, as indicated in Article 108.09 shall apply for failure to achieve any of the listed Partial Completion Dates, Substantial Completion Dates, Project Completion Dates, and other specific Work task completion requirements. Calendar day is defined as: “Any calendar day between April 1 and November 30 inclusive, except Saturdays, Sundays or legal holidays. If the City approves work on Saturday, the Contractor will not be charged a calendar day for work done on that Saturday.” Claims for extension or shortening of the Substantial Completion Times and Project Completion Time shall be based on written notice delivered by the party making the claim to the other party and to the Engineer promptly, but, in no event, later than thirty (30) calendar days after the occurrence of the event giving rise to the claim and stating the nature of the claim.”

Add the following paragraph to Article 108.07

“The Engineer shall have no authority to suspend the Work, wholly or in part, for any reason. All rights conferred onto the Engineer for suspending the Work by Standard Specification Articles 105.01 and 108.07 shall be the sole right of the Owner.”

MEASUREMENT AND PAYMENT

Add the following paragraphs to Article 109.02:

“All the requirements of the Supplemental Standard Specifications pertaining to Sections 100 to 109 of the Standard Specifications are considered incidental to the Work, and no separate or additional payment will be made, except as otherwise indicated, for complying with said requirements. The Owner has the authority to withhold any payment if satisfactory progress is not made by Contractor to complete any work on the Contract.

The cost of removal of any temporary surfaces, trench backfill or other temporary materials above

the subgrade level in areas where final surface restoration is to be performed shall be incidental to the Contract and no additional separate payment will be made except as indicated on the Plans.

Existing facilities or property damaged by construction activities, including settlement, whether through result of Contractor's negligence or as a normal result of the means and methods employed by the Contractor, shall be restored to original condition. Restoration of damaged areas will be considered incidental to the Work and the cost shall be included as part of the unit or lump sum price item to which the restoration pertains.

Payment for each item will be made at the unit or lump sum price bid for that item. The cost of all other related or incidental work required by the plans and specifications shall not be measured or paid for as a separate item, but shall be included as part of the unit or lump sum price item to which the work pertains. Failure to list all such related or incidental work for the bid items shall not invalidate this stipulation."

Delete Article 109.07 and replace it with the following:

"109.07 Partial Payments and Retainage. The Owner will pay the Contractor monthly for Work completed in accordance with the Contract Documents. Applications for Payment from the Contractor (and subcontractors) shall be prepared and submitted by the Contractor with all supporting documents to the Engineer. Supporting documents to be submitted with Applications for Payment shall include, but are not limited to:

Documents to be Submitted With Applications for Partial Payment

- (a) MBE/WBE/EBE Monthly Utilization Report
- (b) All delivery tickets for concrete and asphalt.
- (c) Lien Waivers
- (d) Construction Schedule Update
- (e) Certified payrolls for general contractor and sub-contractors

Failure to submit any of the above documents may cause the payment application to be rejected.

Lien waivers shall accompany each Application for Payment and shall reflect the amount paid to each subcontractor, and supplier, and their respective supporting lien waivers. Contractor's lien waivers submitted with interim Applications for Payment shall reflect all costs up to the date of the Application. Lien waivers from subcontractors, suppliers and others accompanying interim Applications for Payment may be submitted one month in arrears. Lien waivers submitted with the final Application for Payment shall reflect the full values of Contractor's efforts; and, all subcontracts, materials purchases, and other Project costs.

Applications for Payment shall be reviewed by the Engineer within ten (10) calendar days of the submittal and returned to the Contractor for correction or forwarded to the Owner for approval, as appropriate. Engineer and Contractor must agree to quantities forwarded to the Owner. Any disputed quantities not included in the Application for Payment must be resolved within thirty (30) calendar days with any adjustments from disputed quantities to be included on the following

Application for Payment. Applications for Payment certified by the Engineer must be in the City offices by the close of business on the last working day of each month. The Owner will pay the Contractor within thirty (30) calendar days of receipt of Applications for Payment certified by the Engineer.

Retainage shall be withheld as follows:

"There shall be deducted from the amount so determined for the first 50 percent of the completed work a sum of ten percent to be retained until after the completion of the entire work to the satisfaction of the Engineer. After 50 percent or more of the work is completed, the City may, at its discretion, certify the remaining partial payments without any further retention, provided that satisfactory progress is being made, and provided that the amount retained is not less than five percent of the total adjusted contract price."

Delete the first, third, and fourth paragraphs of Article 109.08 and add the following:

"Final payment will be made within sixty (60) calendar days after the Work is fully completed and accepted by the Owner and the Contract fully performed. Request for final payment shall be prepared by the Contractor and accompanied by the documentation hereinafter listed. Quantities for this Contract shall be subject to the contract unit price applied to final measured quantities.

Neither the final payment nor any part of the retained percentage shall become due until the Contractor delivers to the Owner a complete release of all liens arising out of this Contract, or receipts in full in lieu thereof, and in either case, an affidavit that so far as he has the knowledge or information, the releases and receipts include all the labor and material for which a lien could be filed, but the Contractor may, if any subcontractor refuses to furnish a release or receipt in full, furnish a bond satisfactory to the Owner, to indemnify the Owner against any lien. If any liens remain unsatisfied after all payments are made, the Contractor shall refund to the Owner all moneys that the Owner may be compelled to pay in discharging such liens, including all costs and Attorney's fees.

With his final payment request, the Contractor shall submit the following data:

**Documents to be Submitted With
Application for Final Payment**

- (a) MBE/WBE/EBE
Utilization Final Report
- (b) Contractor prepared Record - Drawings

Add the following as the first two paragraphs of Article 109.09:

"The Contractor shall notify the Engineer immediately when the Contractor becomes aware of any circumstances which the Contractor believes may lead to a claim for extra cost. Where possible, the Contractor shall delay proceeding with work which may result in the claim for extra cost until the Engineer has had a reasonable opportunity to review the situation, unless such delay will materially disrupt the prosecution of the Work or unless immediate Contractor action is required to resolve an emergency which endangers life or property. The purposes of the Engineer's review are: to verify that a claim for extra cost may be warranted, to make modifications to the Work to avoid or minimize the extra cost, and/or to monitor the Contractor's performance of the work generating the extra cost. For those situations where the Engineer is not notified prior to the Contractor performing work which causes the claim, the amount of extra cost to which the Contractor is

entitled shall not include costs which, in the Engineer's sole opinion, could reasonably have been avoided if the Contractor had notified the Engineer prior to proceeding with the Work.

The Contractor shall submit, in writing, claims for extra cost to the Engineer as soon as possible after the occurrence of the event(s) giving rise to the claim, but not more than thirty (30) calendar days thereafter. Claims shall include appropriate supporting documentation as specified in following paragraphs to justify the extra cost claimed. This documentation shall include, as a minimum: a description of the circumstances which generated the claim, prior notifications provided to the Engineer, and a detailed breakdown of costs incurred by the Contractor. In the event that this documentation cannot be assembled within thirty (30) calendar days or if the extra cost is ongoing, the Contractor shall submit, in writing, whatever partial information is available to keep the Engineer informed of the Contractor's progress. Extra costs incurred by the Contractor solely because of the particular means and methods which the Contractor chooses to perform the Work will not be considered. Claims submitted more than thirty (30) calendar days after the occurrence of the event(s) giving rise to the claim will not be considered."

Delete the first, second and third paragraphs of Article 109.09 sub-paragraph (e) and replace them with the following:

"(e) Procedure. All claims and supporting documentation shall be submitted to the Engineer. The Engineer shall review each claim and advise the Owner of the Engineer's opinion of the relative merit of each claim and the dollar and/or time adjustment which the Engineer believes is warranted, if any. The Owner shall make a determination of the merit of each claim and the dollar and/or time adjustment, if any, which is appropriate for resolution of the claim. If Contractor is dissatisfied with the Owner's decision regarding merit, dollar adjustment, and/or time adjustment associated with a claim, the Contractor may request arbitration in accordance with the following:

- All claims, counter-claims, disputes and other matters in question between the Owner and the Contractor arising out of, or relating to this Agreement or the breach of it, will be decided by arbitration if the parties mutually agree, or in a court of competent jurisdiction within the State.
- Notice of the demand for arbitration shall be filed in writing with the other party to the Contract Documents and with the American Arbitration Association, and a copy shall be filed with the Engineer. Demand for arbitration shall in no event be made on any claim, dispute or other matter in question which would be barred by the applicable statute of limitations.
- The Contractor will carry on the Work and maintain the progress schedule during any arbitration proceedings, unless otherwise mutually agreed in writing."

SUBMITTALS

This section includes general requirements and procedures related to the Contractor's responsibilities for preparing and transmitting submittals to the Engineer to demonstrate that the performance of the Work will be in accordance with the Contract requirements. Submittals include schedules, Contractor's Drawings, calculations, samples, manuals, methods of construction, and record drawings. Other requirements for submittals are specified under applicable sections of the Standard Specifications.

SUBMITTAL REQUIREMENTS

Not later than three days after the pre-construction conference, submit in writing a list of

submittals and a list of materials and equipment that will be purchased giving name, address and telephone number of supplier, manufacturer or processor. No material shall be incorporated into the Work until approval of the source has been given by Engineer. Delivery of materials to the Contract site prior to approval is made at the Contractor's risk and subject to immediate removal at no cost to the Owner, when it is determined that the source is not acceptable.

CONTRACTOR'S DRAWINGS AND OTHER SUBMITTALS

Contractor's drawings shall be neat in appearance, legible and explicit to enable proper review relative to Contract compliance. They shall be complete and detailed to show fabrication, assembly and installation details, catalog data, pamphlets, descriptive literature, and performance and test data. They shall be accompanied by calculations or other sufficient information to provide a comprehensive description of the structure, machine or system provided and its intended manner of use.

Contractor's Responsibility

Each Contractor's drawing submitted by the Contractor shall have affixed to it the following Certification Statement, signed by the Contractor:

"Certification Statement: By this submittal, I hereby represent that I have determined and verified all field measurements, field construction criteria, materials, dimensions, catalog numbers and similar data and I have checked and coordinated each item with other applicable approved drawings and all Contract requirements."

The review and approval of Contractor's drawings by the Engineer shall not relieve the Contractor from his responsibility with regard to the fulfillment of the terms of the Contract. All risks of error and omission are assumed by the Contractor, and the Engineer will have no responsibility therefore.

No portion of the Work requiring a Contractor's drawing shall be started nor shall any materials be fabricated, delivered to the site, or installed prior to the approval or qualified approval of such item. Fabrication performed, materials purchased or on-site construction accomplished which does not conform to approved Contractor's drawings and data shall be at the Contractor's risk. The Owner will not be liable for any expense or delay due to corrections or remedies required to accomplish conformity.

Contract Work, materials, fabrication, and installation shall conform with approved Contractor's drawings.

Identification

Data - All submittals for approval shall have the following identification data, as applicable, contained thereon or permanently adhered thereto.

1. Owner Contract Number.
2. Project name and location.
3. Submittal Numbers. Re-submittals shall bear original submittal number and be lettered.
4. Product identification.

5. Drawing title, drawing number, revision number, and date of drawing and revision.
6. Applicable Contract drawing numbers and specification section and paragraph numbers.
7. Subcontractor's, vendor's, and/or manufacturer's name, address and phone number.
8. Contractor's certification statement.

Catalog Data - Each submittal of catalog data shall have the identification required as hereinbefore stated.

1. Catalogs or brochures submitted in packages of multiple items for approval need the identification only on the exterior. In such instances the identification shall include page and catalog item numbers for items submitted for approval. If one or more of the items in such a submittal are not approved, re-submittal of only the unapproved items is required.
2. Catalog cuts containing various products, sizes and materials shall be highlighted to show particular items being submitted.

Space - Vacant space of approximately 3-1/2-inches high by 4-inches wide shall be provided adjacent to the identification data to receive the Engineer's status stamp.

Shop Drawings

Shop drawings shall show types, sizes, accessories, weights, layouts including plans, elevations and sectional views, component, assembly and installation details, and all other information required to illustrate how applicable portions of the Contract requirements will be fabricated and/or installed. Include manufacturer's certified performance curves, catalog cuts, pamphlets and descriptive literature, as required.

Working Drawings

Submit working drawings as required for changes, substitutions, contractor design items, and designed methods of construction. Requirements for working drawings will be listed in appropriate Specification Sections and/or in Special Provisions. Drawings shall be accompanied by calculations or other information to completely explain the structure, and describe its intended use. Working drawings and calculations as submitted shall be sealed, dated and signed by a Professional Engineer, and/or Structural Engineer as appropriate, registered in the State of Illinois.

Review and approval of such drawings by the Engineer shall not relieve the Contractor from his responsibility with regard to the fulfillment of the terms of the Contract. All risks of error are assumed by the Contractor and the Engineer shall have no responsibility therefore.

Catalog Data

Submittals - 6 copies of catalog data are required for the original submittal and each subsequent re-submittal that may become necessary.

Manufacturer's equipment data shall be certified and shall include materials type, performance characteristics, voltage, phase, capacity, and similar data. Provide wiring diagrams when applicable. Indicate catalog, model and serial numbers representing specified equipment. Provide complete component information to verify all specified required items.

Data Identification - Each submittal shall have all pertinent data contained therein that are applicable to the item submitted for approval, adequately and prominently designated.

Approval Process

Original Submittal - Copies of catalog data specified in Item F and one reproducible sepia and six legible prints of all shop and working drawings shall be submitted to the Engineer for approval in accordance with the Contractor's drawings submission schedule, with all fabrication and installation requirements, allowing at least 30 calendar days for checking and appropriate action by the Engineer. Three copies of all Contractor's drawings will be returned.

Contractor's drawings will be returned, stamped with one of the following classifications:

APPROVED

No corrections, no marks.

APPROVED AS CORRECTED

Minor corrections are required as noted on the submittal. All items may be fabricated as marked without further resubmission. Resubmit corrected copy to the Engineer.

REVISE AND RESUBMIT

Make the necessary corrections and resubmit drawings as per original submission. Thirty (30) calendar days will be allowed for checking and appropriate action by the Engineer. Only one stamped drawing will be returned.

NOT APPROVED

Requires corrections or is otherwise not in accordance with the Contract Documents. Correct and resubmit drawings as per original submission. Thirty (30) calendar days will be allowed for checking and appropriate action by the Engineer. Only one stamped drawing will be returned. Incomplete submittals or submittals not in conformance with this Specification will not be reviewed, but will be returned to the Contractor as "not approved".

INFORMATION ONLY

Items not reviewed or items for which submittals are not required.

Review and approval of Contractor's drawings by the Engineer shall not relieve the Contractor in any way from his responsibility with regard to the fulfillment of the terms of the Contract. All risks of error are assumed by the Contractor and the Engineer shall have no responsibility therefore.

Excessive Reviews of Contractor Drawings and Other Submittals

The Owner's cost for Engineer's effort to review Contractor drawings or other submittals which have been returned two or more times stamped "REVISE AND RESUBMIT" or "NOT APPROVED" shall be borne by the Contractor at a rate of \$120.00 per labor hour for services provided in 2010. Upon completion of each subsequent review, the Engineer will provide the Contractor a summary total of hours expended in performing the review. Moneys due the

Owner for Engineer's cost for third and additional reviews of Contractor drawings and other submittals will be deducted from the next regular payment due the Contractor. The cost for these services shall be deducted from the "Amount Earned to Date" from the next regular payment due the Contractor.

RECORD DRAWINGS

The Contractor shall keep one record copy of all Contract Documents, reference documents, and all submittals at the site in good order and annotated to show all revisions made during the construction process. Such annotations shall be kept updated on a single set of Contract Drawings and will be inspected monthly. Failure to maintain current record drawings will be cause to delay progress payments. Record drawings shall be available to the Engineer at all times during the life of the Contract.

All drawings and Contractor's submittals shall be made a part of the record drawings and shall include the following:

Contract Drawings - Contractor shall annotate or redraft, as required, to show all revisions, substitutions, variations, omissions and discrepancies made or discovered during construction concerning location and depth of utilities, piping, duct banks, conduits, manholes, pumps, valves, vaults and other equipment. Revisions shall be made and shown on all drawing views with actual dimensions established to permanent points.

Contractor's Drawings - Same as above. Include, for example, piping layouts; and duct layouts. Sections and details shall be added as required, for clarity. Prior to preliminary inspection, furnish a reproducible of the record drawings. At the completion of the Contract and before final payment is made, furnish the Engineer one set of reproducible of the finally approved record drawings reflecting all revisions herein described.

The Contractor shall keep a complete to-date record of the actual construction of all work called for under the Plans and Specifications of this contract and as ordered by the Engineer.

Upon completion of this contract, the Contractor shall furnish to the Engineer record contract plan drawings where changes from the original plans have occurred.

The Engineer will make available to the Contractor one set of full size prints of the original contract drawings on which the Contractor shall make the necessary changes to indicate the major changes. The changes shall be made with opaque Higgins carmine red ink, or approved equal, using standard drafting procedures.

Record drawings on Mylar will be prepared by the Engineer based on the changes indicated by the Contractor. All record drawings on Mylar for this contract shall be signed by the Contractor certifying to its major corrections.

PAYMENT

No separate payment will be made for the work in this section; all the costs of such work shall be considered incidental to the items of work to which they pertain.

SAW CUTS

The Contractor shall full-depth saw cut for the removal of existing curb, sidewalk, all structure work, and for all pavement patches. The concrete saw shall be equipped with a diamond blade

of sufficient size to saw pavements full-depth and be capable of accurately maintaining cutting depth. All saw cuts shall be parallel or perpendicular to the curb & gutter, edge of sidewalk, or the edge of pavement, with straight, clean, edges, to the satisfaction of the ENGINEER. This item shall be included with curb & gutter, sidewalk, structure work, and pavement removal. The slurry resulting from the saw cutting work shall be immediately washed away using water to prevent tracking by vehicles or pedestrians to the satisfaction of the ENGINEER.

When removing pavement, curb and gutter, shoulder, and/or any other structures, the use of any type of concrete breakers which might damage the underground public or private utilities or property will not be permitted. Pavement openings must be initiated with hydraulic impact/air hammers and the use of excavator buckets to strike and break pavement is strictly prohibited and will result in an immediate deficiency deduction.

Saw cuts for all work will not be measured for payment and shall be considered as included in the related contract pay item. No separate payment will be made for saw cuts.

If additional surface is damaged or removed due to negligence on the part of the Contractor, the additional work will not be measured for payment but shall be done at the Contractor's expense. It is Contractor's responsibility to determine the thickness of the existing pavement and whether or not it contains reinforcement.

FIBER OPTIC UTILITIES

If the JULIE system locates a City of Evanston fiber optic communication utility, the Contractor/permit holder shall be required to visually expose fiber optic lines by hand digging within three (3) feet of either side of JULIE locate on all construction projects and permit work. This work will not be paid for separately. The cost of this work shall be included in the unit prices bid for various pay items.

CLEARING, TREE REMOVAL AND PROTECTION, CARE AND REPAIR OF EXISTING PLANT MATERIALS

Add the following paragraphs to Article 201.01:

"Trees and shrubs which may be removed for performance of the Work are so designated on the Drawings. It is not anticipated that any other trees or shrubs will need to be removed for performance of the Work. Should the Contractor desire to remove trees or shrubs, the Contractor shall notify the Owner for approval prior to removing any trees or shrubs. Owner will not grant permission for removal of trees or shrubs, unless the Contractor can demonstrate that there is no other practicable way to complete the Work, including augering or hand-excavation.

Owner recognizes that some tree branches will need to be pruned to provide clearance for construction equipment. However, the Contractor shall secure the express permission of the Engineer to trim specific overhanging branches of trees. The maximum permitted height of trimming shall be 14 feet. All tree trimming, pruning, and repair of wound surfaces shall be performed by a licensed arborist approved by the Owner. The Owner will provide appropriate staff to observe tree trimming operations. The Contractor shall provide at least 72-hour notice to the Owner of trimming operations. No trimming shall be done unless Owner's staff is available to observe trimming. Trimming shall be performed to the satisfaction of Owner's staff. The Contractor shall provide proper tree guards to protect trees from damage due to construction equipment and operations.

Trees and shrubs damaged due to construction operations or removed without approval shall be replaced, at Contractor's expense, with trees or shrubs of like species and size, to a maximum trunk size of 6-inches diameter as directed by the Owner. If trees larger than 6-inches diameter are irreparably damaged or destroyed, the Contractor shall replace these trees with trees of like species 6-inches in diameter. Tree trimming, pruning, repair of wound surfaces, removal of trees and shrubs requested by Contractor, and replacement of trees and shrubs irreparably damaged shall be incidental to the items of work to which they pertain.”

Parkway Tree Protection

Prospective contractors are advised that it is the express intent of the City of Evanston to minimize trimming of trees in the work corridors and to vigorously protect the quality of the urban forest. The equipment and methods used to perform any and all portions of the work must be the size and nature that results in the least disruption to the existing environment. The City of Evanston reserves the right to limit the size of the equipment used on the project.

The Contractor shall at all times demonstrate to the satisfaction of the City of Evanston that suitable precautions and due diligence are being observed to protect the natural and improved features of the area. Special and continuing attention will be paid to the maintenance of tree protection fencing and the appropriate observance of tree protection areas as delineated by the fencing.

To insure compliance with the City of Evanston's intent to minimize area disturbances, the following procedures and actions will be followed: When the Engineer determines that a deficiency exists, the Contractor shall be notified. If the contractor fails to rectify the deficiency immediately, the Engineer will impose a daily monetary deduction for each 24-hour period (or portion thereof) the deficiency exists. This time period will begin with the time of notification to the Contractor and end with the Engineer's acceptance of the corrections. The cost of the daily deduction will be \$250 per occurrence per calendar day. In addition, the Contractor will be liable and responsible for any and all corrective and remedial actions required to restore the area or item to comparable pre-project conditions as well as any additional fines and fees as stated in the tree protection requirements in these specifications.

Care of Existing Plant Material. If construction is to occur within the root zone of existing plant material, root pruning and special plant care will be required, as hereinafter specified. All pruning shall be performed by a professional arborist (someone whose principal occupation is the care and maintenance of trees).

The Contractor shall be responsible for taking measures to minimize damage to tree limbs, tree trunks, and tree roots at each work site. All such measures shall be included in the contract price for other works except that payment will be made for Temporary Fence and Earth Saw Cut of Tree Roots as separate pay items.

A. Earth Saw Cut of Tree Roots (Tree Root Pruning):

1. Whenever the proposed excavation falls within the drip-line of a tree, the contractor shall:
 - a. Root prune 6-inches behind and parallel to the proposed edge of trench a neat, clean vertical cut to a minimum depth directed by the City Arborist through all the affected tree roots.
 - b. Root prune to a maximum width of 4 inches using a “Vermeer” wheel matching the following criteria. The root pruner wheel shall be 60” diameter (188” circumference)

carrying 28 pair (56 total) stump cutter teeth with tooth spacing at 6.7" on center. The cutting depth shall be 24" and shall utilize a 65hp tractor. Trenching machines will not be permitted.

- c. Exercise care not to cut any existing utilities.
 - d. If during construction it becomes evident that additional tree roots will require root pruning, the City Arborist and the Contractor shall have the root pruning sub-contractor return to the site to properly root prune the tree at the location directed by the City Arborist. The contractor will be paid for the additional root pruning as described below; however, no additional compensation will be made for remobilization to the construction site.
 - e. For locations where root pruning is performed for the purpose of curb and gutter removal and replacement, the contractor shall root prune 6-inches behind the curbing so as to neatly cut the tree roots.
 - f. Depth of cut shall be 12 inches for curb removal and replacement and 24 inches for structural work. Any roots encountered at a greater depth shall be neatly saw-cut at no additional cost.
 - g. The Engineer or City Arborist will mark locations where earth saw cutting of tree roots is required in the field.
2. All root pruning cuts shall be immediately backfilled with material side cast from the earth-sawing procedure, so that the ground surface is even and no tripping potential exists.
 3. All root pruning work is to be performed through the services of a certified arborist to be approved by the City Arborist.

TREE ROOT PRUNING shall be used to protect all trees within the public right-of-way of the project limits or as directed by the Engineer. This work will be paid for at the Contract unit price per FOOT for TREE ROOT PRUNING measured in place.

The Contract unit price per FOOT for TREE ROOT PRUNING shall be payment in full for all materials, labor and equipment required for: tree root pruning as shown on plan details; and all related work which is not included under other Payment Items.

B. Temporary Fence:

1. The Contractor shall erect a temporary fence around all trees within the construction area to establish a "tree protection zone", as established by City Arborist, before any work begins or any material is delivered to the jobsite. No work is to be performed (other than root pruning), materials stored, or vehicles driven or parked within the "tree protection zone" at any time during the course of construction.
2. The exact location and establishment of the "tree protection zone" fence shall be approved by the City Arborist prior to setting the fence. The fence shall be 48 inches high, plastic poly-type or any other type of highly visible barrier in an open-weave type pattern with large openings. The type, color and pattern of the fence shall be approved by the Engineer prior to erection. This fence shall be properly maintained in an upright manner and shall remain up until final restoration, unless

the Engineer directs removal otherwise. Tree fence shall be supported using T-Post style fence posts with a maximum of 8' spacing. T-posts must be at least six feet in length, two feet of which must be set in the ground. The fence shall be attached to posts and secured with a minimum of three nylon locking ties per post. Utilizing re-bar as a fence post will not be permitted.

3. The fence shall be installed 18" behind and parallel to the curb and between the curb and sidewalk. Fence shall be erected on a minimum of three sides with the fourth sidewalk side being optional. Fence shall be installed at the drip-line of the tree or as listed in the following guidelines:

a. Establish the diameter of the tree at a point four and a half feet above the ground, (referred to as diameter breast height or DBH)

i. Trees with diameters 10 inches and under require root zone protection a minimum of five feet from the center of the tree.

ii. Trees 10 to 19 inches in diameter shall have a minimum root zone protection of 10 feet from the center of the tree.

iii. Trees greater than 19 inches in diameter shall have a minimum root zone protection of 15 feet from the center of the tree.

4. Parking or maneuvering of machinery, stockpiling of materials or any other use will not be allowed upon unpaved areas within 10 feet of the root protection zone of trees or plants designated to be protected.

5. Construction area is defined as all areas within 10 feet each side of roadway improvement location.

6. All work within the "tree protection zone" shall have the Engineer's prior approval. All slopes and other areas not re-graded should be avoided so that unnecessary damage is not done to the existing turf, tree root system or ground cover.

7. The grade within the "tree protection zone" shall not be changed unless approved by the Engineer prior to making said changes or performing the work.

TEMPORARY FENCE shall be used to protect all trees within the public right-of-way of the project limits or as directed by the Engineer. This work will be paid for at the Contract unit price per FOOT for TEMPORARY FENCE measured in place.

The Contract unit price per FOOT for TEMPORARY FENCE shall be payment in full for all materials, labor and equipment required for: providing snow fence as shown on plan details; and all related work which is not included under other Payment Items.

When improvements are required within the "tree protection zone", tree trunk protection will be required.

C. Tree Trunk Protection:

The Contractor shall provide 2 in. by 8 in. by 8 ft. boards banded continuously around each trunk to prevent scarring of trees shown on the plans or designated by the Engineer. For multi-stem trees, saplings, and shrubs to be protected within the area of construction, temporary fencing may be used for trunk protection

TREE PROTECTION shall be used to protect all trees within the public right-of-way of the project limits or as directed by the Engineer. This work will be paid for at the Contract unit price per EACH for TREE PROTECTION measured in place.

The Contract unit price per EACH for TREE PROTECTION shall be payment in full for all materials, labor and equipment required for: installation of trunk boards in accordance with Supplemental Standard Specifications; and all related work which is not included under other Payment Items.

D. Tree Pruning:

Tree pruning shall consist of pruning branches for aesthetic and structural enhancement or as directed by the Engineer. All pruning shall be done according to the current ANSI A300 (part 1) pruning standard. Trees selected for pruning will be cleaned of dead, diseased, or broken branches, thinned appropriately to reduce density of branches, raised to provide vertical clearance for pedestrian and vehicular traffic, and if warranted by species tolerance and specimen needs limbs will be reduced to promote a central leader and good structure. Pruning to provide clearance over the street will be allowed up to 14 feet above the pavement. If additional clearance is needed a request in writing shall be submitted to the City Arborist. All branch pruning to American Elms and Oak trees shall be done between October 15 and April 15, when the trees are dormant.

Under pruning to provide clearance over the street will be allowed up to 14 feet above the pavement. If additional clearance is needed a request in writing shall be submitted to the City Arborist.

TREE PRUNING will be paid for at the contract unit price per EACH for TREE PRUNING, which price shall include under pruning branches to provide clearance over the street, for aesthetic and structural enhancement, of existing trees.

DISPOSAL OF EXCAVATED MATERIAL

This work shall consist of meeting IEPA requirements for the disposal of excavated material including, but not limited to, clean construction or demolition debris (CCDD), uncontaminated soil, and/or contaminated soil. Excavated materials must be removed from the site by the end of each day.

The Contractor will be responsible to provide CCDD and soil fill site operators with all testing information and fees as required by the IEPA and fill site operators.

The City will provide IEPA LPC documentation prior to the start of construction.

EARTH EXCAVATION

This work shall consist of the excavation or removal and satisfactory disposal of only that volume of material, regardless of its nature, which must be excavated or removed to construct the improvement to the lines, grades and cross sections shown in the plans or required by the Engineer.

Earth Excavation shall not include excavation necessary for top soil and sod placement or incidental in the construction of new sidewalks, driveways, curb, vaults, catch basins, manholes, inlets, storm sewers of all types, house drains or other new structures included in the

construction for which the contract unit price includes the cost of excavation.

Earth Excavation shall be measured for payment in cubic yards. The volume shall be determined by the Engineer by the method of average end areas, supplemented by measurements to determine the volume of excavation.

This work will be paid for at the contract unit price per cubic yard for Earth Excavation as herein specified.

TOPSOIL FURNISH AND PLACE

Add the following paragraph to Article 211.04:

“Topsoil shall be pulverized. A minimum thickness of 3-inches of topsoil shall be placed over the full width of disturbed areas to be sodded.”

SODDING, SALT TOLERANT

Add the following paragraph to Article 252.01:

“All grassed areas disturbed by Contractor's operations shall be restored by sodding. To be acceptable, the sod shall be in a live, healthy condition and be knitted to the soil. Sod shall be growing in place for forty-five (45) calendar days prior to measurement. Only living sod that is acceptable will be measured for payment.”

Add the following paragraph to Article 252.02:

“On major roadways (arterial streets, main streets, State and County routes, etc) sod for public parkway areas and other areas within 25 feet of public roadways shall be salt-tolerant. The sod for most residential streets does not have to be salt-tolerant, at the Engineer's discretion. Sod for other areas shall be native sod matching the species, color, and texture of adjoining grass areas as approved by the Engineer.”

Add the following to Article 252.03:

“Sod bed preparation shall include the placement of top soil, including excavating and grading the areas to be sodded to a depth of at least 3-inches below a line connecting the top of the curb and the top of the sidewalk, disposing of the material removed and placing pulverized topsoil on the space so prepared, raked and ready for sodding. The topsoil shall be free from quack grass and weeds and shall be approved by the Engineer before placing. One rolling of the entire surface of the soil shall be made. Existing sidewalks, curbs and trees, and the like, which are not to be removed, shall be protected from damage during the placement of topsoil. Placement of topsoil shall be incidental to the cost of sodding and no separate payment shall be made.”

Add the following paragraph to Article 252.04:

“The Contractor is encouraged to refrain from placing sod during the months of July and August, when possible within the required construction schedule. No sod may be placed between November 1 and March 1 unless approved by the Engineer. Regardless of the time of placement and subsequent climatic conditions, the Contractor shall water sod sufficiently to maintain it in a healthy condition until accepted by the Owner. Sod shall be in a moist condition at the time of cutting and shall be kept in a moist condition until it is placed. Sod cut less than 24 hours before placement is preferred. Sod cut more than 48 hours before placement shall not be used.”

Add the following to Article 252.06:

“The placement of sodding shall consist of preparing the ground surface and furnishing, transporting, and placing sod and fertilizer required in the sodding operations. Fertilizer having an analysis of 10-6-4 or having a different analysis but still meeting the 5-3-2 ratio requirements, shall be applied at such a rate that each acre to be sodded shall receive a total of 160 pounds of the three nutrients specified in Article 1081.08. The fertilizer nutrient will not be paid separately but shall be incidental to the cost of sod placement.”

Delete the first paragraph of Article 252.08 and replace it with the following paragraphs:

“Within eight hours after sod has been placed five gallons of water per square yard shall be applied and the entire surface of sod rolled. Thereafter, on days designated by the Engineer, additional water shall be applied to sodded areas at the rate of three gallons per square yard. The number of additional applications shall not exceed ten and these applications will be required within a forty-five (45) calendar day growing period after the sod has been placed. The cost of this watering program shall be incidental to the cost of sodding.

The Contractor shall perform additional watering to maintain sod in a healthy condition. The cost of **additional watering** shall be incidental to the cost of sodding. Any sodding that does not survive will be replaced by the Contractor at his own expense.”

This work will be paid for at the Contract unit price per SQUARE YARD for SODDING, measured in place for the quantity actually installed within the pay limits shown on the Drawings, as hereinafter specified, or as directed by Engineer. Grassed areas to be restored by SODDING include parkways and all other turf areas which have been disturbed by construction activities.

AGGREGATE BASE COURSE

Section 351 shall apply with the following modifications:

The Contractor shall furnish and place 4 inches or greater depth where indicated in these documents, of crushed limestone conforming to Article 1004.01 with a gradation number of CA-6 for use as the base course for curb and gutter, sidewalks, driveways and pavement as shown on the drawings and as directed by Engineer (aggregate base course for pavement patching, sidewalks, and driveways is incidental to respective item). Base course shall be placed on the prepared subgrade. **Grindings from Portland cement concrete or bituminous pavement removal operations may NOT be allowed for aggregate base course.**

INCIDENTAL HOT-MIX ASPHALT SURFACING

This work shall consist of the preparation of the base, the application of bituminous priming material and the construction of the Hot-Mix Asphalt surface for driveway pavements and speed humps.

The Hot-Mix Asphalt for the Incidental Hot-Mix Asphalt surface shall meet the requirements of Section 406 of the Standard Specifications for Road and Bridge Construction. Areas where the Incidental Hot-Mix Asphalt surfacing will be placed shall have the base primed. The rate of application of prime will be as specified in Article 406.05.

The Hot-Mix Asphalt mixture may be spread and finished by approved hand methods or a finishing machine approved by the Engineer.

The Hot-Mix Asphalt mixture shall be rolled and compacted to the satisfaction of the Engineer with tandem roller meeting the requirements of Article 1101.01 of the Standard Specifications

for Road and Bridge Construction.

This work will be paid for at the contract unit price per ton for "INCIDENTAL HOT-MIX ASPHALT SURFACING", which price shall include all labor, materials and equipment necessary to complete the work. Saw cutting, HMA surface removal, and preparation of the surface for speed hump will not be paid for separately but shall be considered as included in the contract unit price for incidental HMA surfacing.

The cost of Bituminous Materials (Tack Coat) will not be paid for separately but shall be incidental to the unit price per ton for INCIDENTAL HOT-MIX ASPHALT SURFACING.

REMOVAL OF EXISTING DRIVEWAY PAVEMENT AND SIDEWALK

This work shall consist of the removal and satisfactory disposal of all existing pavement, base course, stabilized sub-base including driveway pavement and sidewalk.

Refer to Article 440 of the Standard Specifications for Road and Bridge Construction.

Driveway Pavement Removal shall be paid for at the CONTRACT unit price per square yard and Sidewalk Removal shall be paid for at the CONTRACT unit price per square foot and include all costs of breaking, saw-cutting where necessary or as directed by the Engineer, removing and disposing of said pavement or sidewalk.

DRIVEWAY PAVEMENT REMOVAL shall include removal of brick and curb/gutter and preparation of the sub-grade for the placement of top soil and sodding. Placement of Top Soil and Sodding is paid separately.

PORTLAND CEMENT CONCRETE DRIVEWAY PAVEMENT

Add the following paragraphs to Article 423.01:

Materials: - Materials for concrete shall be in accordance with Section 420 as applicable. Class SI concrete shall be used. Forms shall be a minimum of 2" x 8" lumber or its approved equal, held in place by stakes or braces with the top edges true to line and grade. The driveway pavement shall be six (6") inches or eight (8") inches thick. Three-quarter (3/4") inch thick expansion joint material shall be placed between the curb and the full width of the proposed driveway. Contraction joints shall be provided.

"Aggregate Base Course required for necessary grading will not be paid for separately and constructed in accordance with section 351 of the Standard Specifications."

Curing and Protection: Curing shall be in accordance with Article 1022.01. Curing compound shall be Type III. Protect all surfaces from sun. During hot weather, keep temperature of concrete below 90 degrees Fahrenheit. During cold weather, keep temperature of concrete between 50 degrees F and 70 degrees F for 3 to 5 days. Protect from frost and rapid drying for 6 days. The Contractor shall be solely responsible for protecting his work from vandalism. **All vandalized concrete work shall be removed and replaced at the Contractor's expense.**"

This work will be paid for at the Contract unit price per SQUARE YARD for PORTLAND CEMENT CONCRETE (PCC) DRIVEWAY PAVEMENT, of the thickness specified, measured in place. Payment shall be made for the quantity of pavement actually installed within the pay limits shown on the Drawings or as directed by Engineer.

The Contract unit price for PCC DRIVEWAY PAVEMENT shall be payment in full for all materials, labor, and equipment required for: final grading of aggregate base course; reinforcement, if required; pavement placement, curing, and protective coating; and all related work required to complete the installation which is not included under other Payment Items.

PCC DRIVEWAY PAVEMENT installation outside the limits shown on the Drawings due to damage caused by Contractor's operations or for Contractor's purposes shall be considered incidental to combined sewer, relief sewer, storm sewer, and sanitary sewer, construction and no separate payment shall be made.

PORTLAND CEMENT CONCRETE SIDEWALK

Add the following sentences to Article 424.01:

"The Work shall also include adjustments to surface elements such as buffalo boxes, valve covers, manhole covers, vault covers, etc. to final grades."

Add the following sentences to Article 424.02:

"Curing shall be in accordance with Article 1022.01. Curing compound shall be Type III. Protect all surfaces from sun. During hot weather, keep temperature of concrete below 90 degrees Fahrenheit. During cold weather, keep temperature of concrete between 50 degrees F and 70 degrees F for 3 to 5 days. Protect from frost and rapid drying for 6 days." The Contractor shall be solely responsible for protecting his work from vandalism. **All vandalized concrete work shall be removed and replaced at the Contractor's expense.**"

Add the following sentences to Article 424.04:

"The Aggregate Base Course required for necessary grading will not be paid for separately and constructed in accordance with section 351 of the Standard Specifications."

Add the following paragraphs to Article 424.06:

"Concrete placement will be permitted if air temperature is 40 degrees Fahrenheit or higher. Concrete pours shall be ended at expansion or control joints. Partial slabs shall not be allowed. The surface shall be divided by control joints extending to the depth of the slab. Control joints shall be tooled first, saw-cut to proper depth and shall be spaced at 5-foot or other uniform intervals as directed by the Engineer. All edges and intermediate joints of sidewalks shall be shaped with an edging tool having a ½ inch radius. Surfaces of sidewalks shall have a light broom finish, except handicapped ramps at intersections, which shall be finished as shown on the Drawings.

All sidewalk removed shall be formed within 3 working days of removal. New sidewalk shall be poured within 1 working day of being formed. The forms shall be removed within 1 working day after the concrete pour and the restoration adjacent to new sidewalk shall be done with 24 hours after removal of the forms. All low areas shall be filled in to match the surrounding grades within 72 hours of the sidewalk being poured.

The Contractor shall be solely responsible for protecting his work from vandalism. All vandalized concrete work shall be removed and replaced at the Contractor's expense"

Add the following paragraphs to Article 424.09:

"The product used for detectable warnings shall be Prefabricated Detectable Warning Panels (Red Brick) manufactured by one of the following:

- > Access Products, Inc. (888-679-4022)/ Supplier (630-689-7574)
- > Armorcast Products Company (818-982-3600)

> Detectable Warning Systems, Inc. (866-999-7452)
> www.TUFTILE.com (888-960-8897).”

BRICK PAVER REMOVAL AND REPLACEMENT

Where brick pavers are present adjacent to sidewalk or curb to be removed and replaced, the Contractor shall obtain approval by the Engineer to disturb the brick pavers during construction. Upon completion of the sidewalk and/or curb replacement, any brick pavers disturbed during construction shall be replaced to pre-construction locations and grades. Any brick pavers damaged during construction or removed without authorization by the Engineer shall be replaced by the Contractor at the Contractor's own expense.

This work will be paid for at the Contract unit price per SQUARE FOOT for BRICK PAVER REMOVAL AND REPLACEMENT.

HOT-MIX ASPHALT SURFACE REMOVAL

In addition to the requirements of Section 440 of the Standard Specifications, the Specifications shall be modified to include the following:

This work shall consist of removing the existing bituminous surface and underlying HMA base, PCC base, brick base, or aggregate base at varying depths to the limits specified on the plans and/or as directed by the Engineer in accordance with the applicable portions of Section 440 of the Standard and Supplemental Specifications. The provisions of Article 440.03 of the Standard Specification should be modified to include the following:

Pavement patching shall be completed after the pavement is milled. The ENGINEER will inspect the milled pavement and identify the areas which will require pavement patching. If new curb and gutter is part of the project, the curb and gutter shall be constructed prior to the start of the milling operation.

HMA Surface Removal, Variable Depth shall include any additional passes of the milling machine required to remove an existing quarter crown and establish the proposed pavement cross slope as shown on the plans. These operations shall be considered incidental to the work, and no separate payment shall be made.”

This work will be paid for at the Contract unit price per SQUARE YARD for HOT MIX ASPHALT SURFACE REMOVAL, at the depth specified, as shown on the Drawings and/or as directed by the Engineer.

Basis of Payment: This work will be paid for at the Contract unit price per square yard for HOT-MIX ASPHALT SURFACE REMOVAL, which price shall include all labor, material and equipment necessary to perform the work as specified herein

Cold milling outside the pay limits specified to repair damage caused by Contractors operations or which have been removed/replaced for Contractor's purposes shall be considered incidental to combined, relief, storm, and sanitary sewer construction and no separate payment shall be made.

CONCRETE GUTTER, CURB, MEDIAN, AND PAVED DITCH

Delete Article 606.01 and replace it with the following:

“606.01 Description. This work shall consist of concrete curb type B, combination concrete curb and gutter type B-6.12 and B-6.12 modified, and removal/replacement of existing medians.”

All curb and gutter removed shall be formed within 2 working days of removal. New curb and gutter shall be poured within 1 working day of being formed. The forms shall be removed within 1 working day after the concrete pour and the restoration behind the new curb shall be done with 24 hours after removal of the forms. All low areas shall be filled in to match the surrounding grades within 72 hours of the curb being poured.

Add the following Subparagraphs to Article 606.02:

(g) Base. A minimum of four (4”) inches compacted thickness of aggregate base course shall be placed on the subgrade prior to construction of the proposed concrete curb and gutter.

(h) Forms. The use of a slip-form or curb machine is allowed, but the Contractor is advised that variable face height curb is required in many parts of the Project to match existing curbs, roadways and parkway grading. Additional pavement patching, restoration or excavation beyond the requirements of this proposal, as required for or resulting from the use of such a machine, will not be considered for additional payment and should be considered incidental to its use. Excavation to accommodate the installation of concrete forms or use of slip-form shall be limited to 12 inches from back of proposed curb. Hand forming shall be required in the vicinity of specific trees where the root zones are near and/or have overgrown the existing curb line. These locations will be determined by the City Arborist.

(i) Curing. Curing shall be in accordance with Article 1022.01. Curing compound shall be Type III. Protect all surfaces from sun. During hot weather, keep temperature of concrete below 90 degrees Fahrenheit. During cold weather, keep temperature of concrete between 50 degrees F and 70 degrees F for 3 to 5 days. Protect from frost and rapid drying for 6 days. The Contractor shall be solely responsible for protecting his work from vandalism. All vandalized concrete work shall be removed and replaced at the Contractor's expense.”

Add the following sentence to Article 606.06 - Placing Concrete.

“The transition from full height curb to depressed curb shall be made at a maximum rate of three (3) inches per foot of length.”

Delete the last sentence of the first paragraph of Article 606.07.

Add the following paragraphs to Article 606.07:

“Expansion joints consisting of pre-molded bituminous expansion joint filler, one-half inch in thickness and two greased 1-inch diameter dowel bars with expansion caps shall be placed at 50-foot intervals. When curb and gutter is constructed adjacent to flexible pavement, a 1-inch thick preformed expansion joint, conforming to the cross-section of the curb and gutter, shall be installed at points of curvature for short-radius curves and at construction joints.

Contraction joints shall be placed between expansion joints at distances not to exceed twenty-five (25) feet. Contraction joints shall be formed using steel templates one-eighth inch in thickness, equal to the width of the gutter or curb, and penetrating at least two (2) inches below the surface of the curb and gutter; using three-quarter ($\frac{3}{4}$) inch thick preformed expansion joint filler placed fully across the curb or gutter; or by sawing to a depth of at least two (2) inches after the concrete is four-hours, but not more than twenty-four hours old. If steel templates are used, they shall be left in place until the concrete has set sufficiently to hold its shape but shall be removed while the forms

are still in place. Template-formed or sawed joints shall be sealed in accordance with Article 420.12.

All longitudinal joints, except adjacent to flexible pavement, shall be provided with No. 6 epoxy coated steel tie bars thirty (30) inches long at 36" on center conforming to Article 1006.10 and installation in accordance with IDOT Standard 606001. This work is incidental to the curb pay item.

Hand removal and hand forming of the curb and gutter shall be required in the vicinity of specific trees and their root zones. These individual locations shall be determined, in the field, by the City Arborist. These operations shall be considered incidental to the work, and no separate payment shall be made. Excavation to accommodate the installation of concrete forms or use of slip-form shall be limited to 12 inches from back of proposed curb.

The proposed curb and/or curb & gutter flag thickness shall meet the bottom of the existing pavement and extend to the top of the proposed edge of pavement as shown on the plans. No separate payment shall be made for additional concrete used."

Delete Article 606.15 and replace it with the following:

"This work will be paid for at the Contract unit price per LINEAR FOOT for CONCRETE CURB TYPE B, COMBINATION CONCRETE CURB AND GUTTER TYPE B-6.12, and COMBINATION CONCRETE CURB AND GUTTER TYPE B-6.12 MODIFIED. Curb and gutter will be measured in place for the quantity actually removed and replaced within the pay limits shown on the Drawings or as directed by Engineer.

These Contract unit prices shall be payment in full for all materials, labor and equipment required for: site preparation, including removal, replacement and/or repair of fences and other site objects; saw-cutting, removal and disposal of existing curbs/gutters and other structures; excavation, including removal and disposal of excess excavated materials; final grading of aggregate base course, backfill; furnishing and installing all joints as required, including epoxy coated tie bars; curing; protection; and all related work required to complete the installation which is not included in other Payment Items. Modified (depressed) curbs shall be paid for at the same Contract unit price as standard type B, B6.12.

Removal/replacement of curb/gutter will be paid for where placed within the standard trench width of new sewers, manholes, catch basins, and inlets, where shown on the Drawings outside the standard trench width or where directed by Engineer.

Removal/replacement of curb/gutter outside the pay limits specified which have been damaged by Contractors operations or which have been removed/replaced for Contractor's purposes shall be considered incidental to the work and no separate payment shall be made."

CONSTRUCTION LAYOUT AND STAKING

This work shall consist of surveying local control points to establish horizontal and vertical control required for construction of concrete curb, sidewalks, and related contract items of work. These stakes or markings must be maintained throughout construction. The survey foreman will be responsible for the review of stakes and marking with the Engineer prior to the final placement of any materials.

The contractor will also be required to identify the property lines and ROW in order to accurately install new chain link fence.

This work will be measured and paid for at the contract unit price LUMP SUM as CONSTRUCTION LAYOUT AND STAKING, which price includes all labor, material and equipment necessary to survey control points, lines, establish stakes and marking, and the review of all such stakes and markings with the Engineer.

The limits of concrete construction contract items will be provided by the Engineer.

STREET SWEEPING

Add the following paragraphs to Article 107.15:

“The Contractor shall utilize a mechanical street sweeper to clean streets affected by the Contractor's operations, including haul routes, at least twice per week and additionally as directed by the Engineer. Liquidated Damages shall be assessed as outlined in the Bid Form if the Contractor fails to utilize a mechanical street sweeper to the satisfaction of the Engineer. The street-sweeper shall be a full-sized, municipal-type sweeper having dust collection and street washing capabilities. If, in the opinion of the Engineer, dust becomes a problem despite the normal cleanup measures of street sweeping, the Contractor shall wash down the pavement, spread calcium chloride as a palliative, or re-sweep streets as necessary, all at no additional cost to the Owner. The Contractor shall keep sufficient quantities of calcium chloride on site, for use as directed by the Engineer for dust control. The contractor shall provide cleanings twice per week and additionally as directed by the Engineer.

This work will be paid for at the Contract unit price per EACH for STREET SWEEPING, which price shall be payment in full for labor, equipment and materials required to complete the work.

TRAFFIC CONTROL AND PROTECTION

Delete Article 701.20 and replace it with the following:

This work will be paid for at the Contract LUMP SUM price for TRAFFIC CONTROL AND PROTECTION. This lump sum price shall be payment in full for all materials, labor and equipment required for: handling, furnishing, transporting, installing, maintaining, relocating and removing all traffic control devices and signage required for to fully protect construction operations and the general public; including implementing any detour plans shown on the Drawings. This lump sum price shall also include all materials, labor and equipment required for: furnishing, installing, relocating and removing steel plates and other temporary bridging over trenches, auger pits, receiving pits and other areas disturbed by construction activities. Contractor shall also refer to the IDOT Standards included herein for additional traffic control measures. The Contractor is advised that specific liquidated damages apply for failure to maintain traffic control devices.

ENVIRONMENTAL CONTROL

The Contractor shall be responsible for furnishing all necessary items for fulfilling the Work described herein and in the Contract Plans for environmental protection including prevention and control of erosion and sedimentation that results directly or indirectly from the Project.

PREVENTION OF WATER POLLUTION

The Contractor shall take all such precautions in the conduct of his operations as may be necessary to avoid contaminating the water in adjacent watercourses or water storage areas including wells whether natural or man-made.

All earthwork, moving of equipment, water control of excavations, and other operations likely to create silting, shall be conducted so as to minimize pollution of watercourses or water storage areas.

Water used during the Contract Work, which has become contaminated with oil, bitumens, harmful or objectionable chemicals, sewage or other pollutants, shall be disposed of so as to avoid affecting all nearby waters and lands. Under no circumstances shall the Contractor discharge pollutants into any watercourse or water storage area. Do not allow water used in aggregate processing, concrete curing, foundation and concrete lift cleanup or any other waste to directly enter a stream untreated. When water from adjacent natural sources is used in the Contract Work, intake methods shall be such as to avoid contaminating the source of supply or becoming a source of erosion or sedimentation.

NOISE AND AIR POLLUTION CONTROL

Conduct operations so as not to violate any applicable ordinances, regulations, rules and laws in effect in the area at the date of bid opening pertaining to noise and air pollution and to conform to all provisions in effect at the date of bid opening as set forth in the Rules and Regulations Governing the Control of Air Pollution and noise pollution in the State of Illinois.

PLANT PEST CONTROL

All soil moving or handling equipment that has operated in or will operate in regulated areas shall be subject to plant quarantine regulations. In general, these regulations require the thorough cleaning of soil from equipment before such equipment is moved from regulated areas to uninfected areas. Complete information may be obtained from the regional office of the Plant Pest Control Division of the United States Department of Agriculture.

PRESERVATION OF NATURAL RESOURCES

All construction operations, contract work, clean up and the condition of the adjacent terrain upon completion of the Work shall fully comply with all applicable regulations and laws concerning the preservation of natural resources.

DUST CONTROL

Throughout the entire construction period, maintain dust control by use of water sprinklers or chemical dust control binder as may be approved by the Engineer.

PAYMENT

No separate payment will be made for the work in this Section; all the costs of such work shall be considered incidental to the items of work to which they pertain.

CHAIN LINK FENCE

This work includes the furnishing and installation of a chain link fence in accordance with the applicable sections of Article 664, IDOT highway standard 664001, and as shown on the plans.

The fence will include a top rail and bottom tension wire with materials to match the existing fence. Gate design shall match existing gate features. All posts will be set in 12" diameter concrete footings at 24" deep.

Product cut sheets must be approved by the City before purchase and installation.

This work will be paid for at the Contract unit price per FOOT for CHAIN LINK

FENCE REMOVAL AND REPLACEMENT, at the height specified and per EACH for CHAIN LINK FENCE DOUBLE SWING GATE, 12-FEET. The price shall be payment in full for labor, equipment and materials required to complete the work.

2022 CDBG SIDEWALK IMPROVEMENTS AND GAP INFILL CITY OF EVANSTON BID #22-27

INDEX OF SHEETS

- 1 TITLE SHEET
- 2 GENERAL NOTES AND SUMMARY OF QUANTITIES
- 3 EXISTING CONDITIONS AND DEMO PLAN
- 4 SITE PLAN
- 5 DETAILS

PROJECT MANAGER

CHRISTOPHER VENATTA, PE
SENIOR PROJECT MANAGER
PUBLIC WORKS AGENCY
BUREAU OF CAPITAL PLANNING AND ENGINEERING

2100 RIDGE AVENUE
EVANSTON, ILLINOIS
(847) 448-8129
CVENATTA@CITYOFEVANSTON.ORG

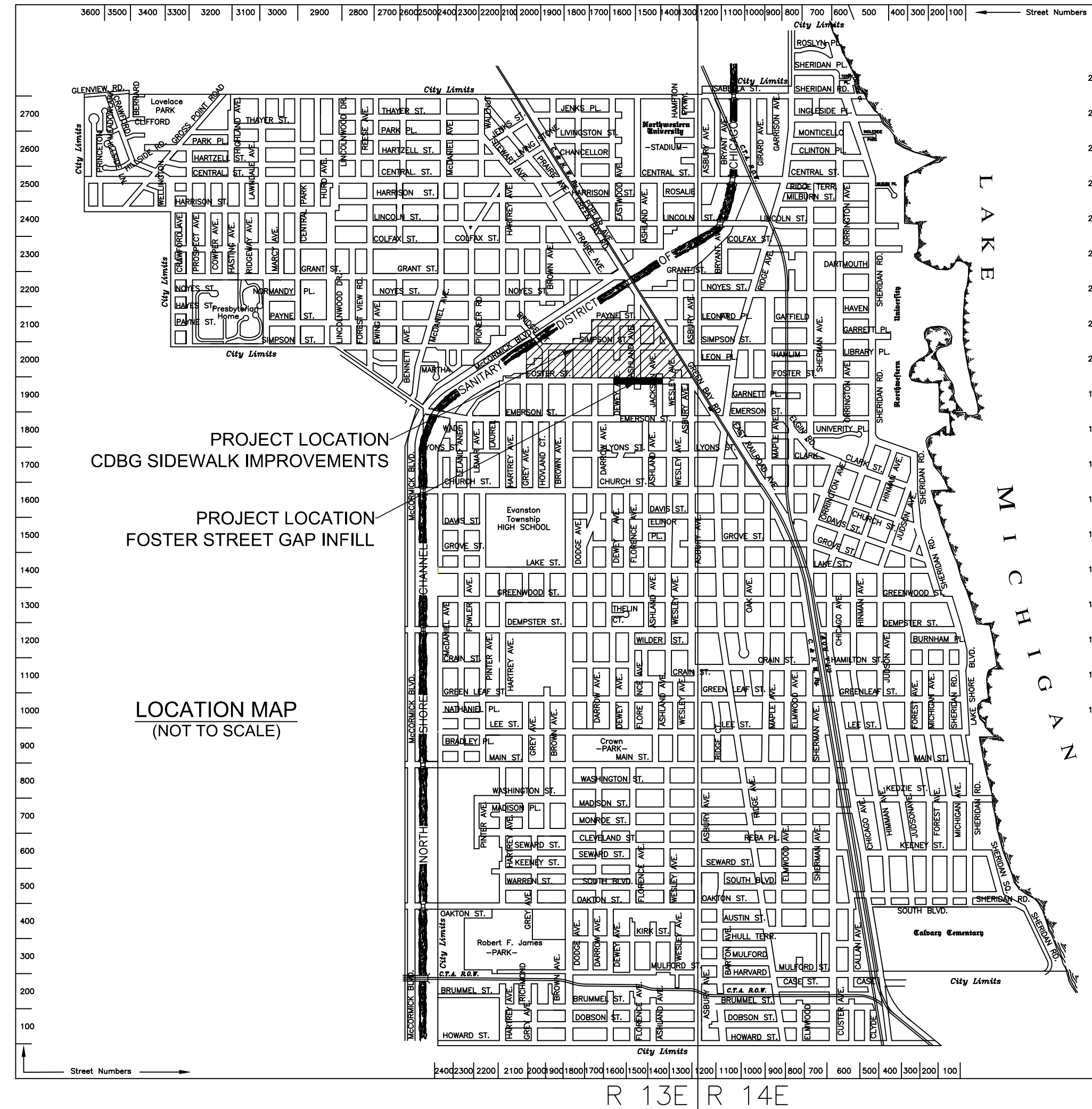

HIGHWAY AND TRAFFIC STANDARDS

- 424001-11 PERPENDICULAR CURB RAMPS FOR SIDEWALKS
- 424016-05 MID-BLOCK CURB RAMPS FOR SIDEWALKS
- 424021-06 DEPRESSED CORNER FOR SIDEWALKS
- 424026-03 ENTRANCE / ALLEY PEDESTRIAN CROSSINGS
- 606001-08 CONCRETE CURB TYPE B AND COMBINATION CONCRETE CURB AND GUTTER
- 701501-06 URBAN LANE CLOSURE, 2L, 2W UNDIVIDED
- 701801-06 SIDEWALK, CORNER OR CROSSWALK CLOSURE
- 701901-08 TRAFFIC CONTROL DEVICES

NOTICE

THE EXACT LOCATION OF ALL UTILITIES SHALL BE VERIFIED BY THE CONTRACTOR PRIOR TO CONSTRUCTION ACTIVITIES. FOR UTILITY LOCATION CALL J.U.L.I.E. AT 1-800-892-0123.

X:\Public Works\Engineering\Engineers\FY 2022 PROJECTS\CDBG Sidewalk Improvements and Gap Infill\CAD\Sheet Files\1 COVER.dwg

	4	
	3	
	2	
	1	
DATE	NO.	REVISION

SCALE	BID NUMBER: 22-27	ISSUED FOR: CONSTRUCTION	DESIGNED BY: BN	SHEET 1 OF 5
HORIZONTAL N/A		DATE: 03/18/2022	DRAWN BY: BN	
VERTICAL N/A			CHECKED BY: CV	

X:\Public Works\Engineering\2022 Projects\CDBG Sidewalk Improvements and Gap Infill\CAD\Sheet Files\2. GENERAL NOTES.dwg

FEATURE	EXISTING	PROPOSED
ASPHALT		
BACK OF CURB		
BUILDING		
CABLE TV		
CENTERLINE		
COMBINED SEWER		
CONCRETE		
CONTOUR MAJOR		
CONTOUR MINOR		
DRIVEWAY		
EASEMENT		
ELECTRIC LINE		
EDGE OF PAVEMENT		
FACE OF CURB		
FENCE		
FLOWLINE		
GAS LINE		
GRAVEL		
LANDSCAPING		
MISCELLANEOUS		
PROPERTY LINE		
RAILROAD TRACKS		
ROW		
SANITARY SEWER		
SIDEWALK		
STORM SEWER		
STREETLIGHT CABLE		
STRIPING		
TELEPHONE LINE		
TYPE B CURB		
TYPE B6.12 CURB AND GUTTER		
WATER MAIN (SIZE VARIES)		
BUSH LINE		
CONTROL		
ELECTRIC STRUCTURE		
GUY WIRE		
HANDHOLE		
JUNCTION BOX		
POWERPOLE		
SPLICE BOX		
STREET LIGHT		
TELEPHONE POLE		
TELEPHONE STRUCTURE		
TRAFFIC SIGNAL		
TRANSFORMER		
GAS METER		
GAS VALVE		
BUSH		
STUMP		
TREE		
CATCH BASIN		
INLET		
MANHOLE		
CLEANOUT		
BUFFALO BOX		
FIRE HYDRANT		
VALVE BOX		
VALVE VAULT		
WATER METER		
URILITY/UTILITY ADJUSTMENT		
BOLLARD		
BUS SHELTER		
CONTROL POINT		
GATE		
MAILBOX		
POST		
PROPERTY MARKER		
SIGN		
SUMMIT		
SURVEY BENCHMARK		
STRUCTURE TO BE FILLED WITH SAND		
STRUCTURE TO RECEIVE NEW FRAME AND GRATE		
FRAMES AND GRATES TO BE ADJUSTED		
FRAMES AND GRATES TO BE ADJUSTED (SPECIAL)		
STRUCTURE TO BE RECONSTRUCTED		
PROPOSED REMOVAL		
DETECTABLE WARNINGS		
SIDEWALK REMOVAL AND REPLACEMENT		
PROPOSED SIDEWALK		
DRIVEWAY REMOVAL AND REPLACEMENT (CONC)		
DRIVEWAY REMOVAL AND REPLACEMENT (ASPH)		
PAVEMENT REMOVAL AND REPLACEMENT		
PAVEMENT REMOVAL		
HMA OR CONCRETE SURFACE REMOVAL		
GRASS OR SOD		

GENERAL NOTES

- ALL CONSTRUCTION SHALL BE PERFORMED ACCORDING TO THE ILLINOIS DEPARTMENT OF TRANSPORTATION "STANDARD SPECIFICATIONS FOR ROAD AND BRIDGE CONSTRUCTION" LATEST EDITION, THE "SUPPLEMENTAL SPECIFICATIONS AND RECURRING SPECIAL PROVISIONS" LATEST EDITION, THE "STANDARD SPECIFICATIONS FOR WATER AND SEWER MAIN CONSTRUCTION IN ILLINOIS" LATEST EDITION, THE DETAILS IN THESE PLANS, THE CONTRACT DOCUMENTS, ALL APPLICABLE REQUIREMENTS OF THE ILLINOIS DEPARTMENT OF TRANSPORTATION, THE IEPA AND ORDINANCES OF AUTHORITIES HAVING JURISDICTION AND ALL ADDENDA THERETO.
- ALL FULL DEPTH SAW-CUTTING OF EXISTING PAVEMENT, CURB, SIDEWALKS AND SURFACES WHEN REQUIRED FOR REMOVAL OR CONSTRUCTION OR AS DIRECTED BY THE ENGINEER WILL NOT BE PAID FOR SEPARATELY BUT SHALL BE CONSIDERED INCIDENTAL TO THE VARIOUS PAY ITEMS.
- THE CONTRACTOR SHALL BE RESPONSIBLE FOR CONTACTING THE OWNERS OF ALL EXISTING UTILITIES SO THAT THE UTILITIES AND THEIR APPURTENANCES MAY BE LOCATED AND ADJUSTED OR MOVED, IF NECESSARY, PRIOR TO THE START OF CONSTRUCTION. ALL EXISTING UTILITIES SHALL BE PROTECTED, SUPPORTED AND MAINTAINED IN SERVICE AND RESTORED TO THE CONDITION IN WHICH THEY WERE FOUND, OR BETTER, AT NO EXTRA COST TO THE CONTRACT.
- THE CONTRACTOR SHALL BE RESPONSIBLE FOR THE PROTECTION OF ALL UNDERGROUND UTILITIES EVEN THOUGH THEY MAY NOT BE SHOWN ON THE PLANS. ANY UTILITY THAT IS DAMAGED DURING CONSTRUCTION SHALL BE REPAIRED OR REPLACED BY THE CONTRACTOR AT HIS OWN EXPENSE.
- ALL ROAD SIGNS, STREET SIGNS, TRAFFIC SIGNS, AND PARKING LOT SIGNS WHICH NEED TO BE RELOCATED OR MOVED DUE TO CONSTRUCTION SHALL BE TAKEN DOWN AND STORED BY THE CONTRACTOR AT HIS OWN EXPENSE, EXCEPT THOSE WHICH THE ENGINEER DEEMS NECESSARY FOR PROPER TRAFFIC CONTROL. AFTER COMPLETION OF THE WORK, THE CONTRACTOR SHALL, AT HIS OWN EXPENSE AND AT THE DIRECTION OF THE ENGINEER, RESET ALL SAID SIGNS AT THE LOCATION DESIGNATED BY THE ENGINEER.
- WHENEVER, DURING CONSTRUCTION OPERATIONS, ANY LOOSE MATERIAL IS DEPOSITED IN THE FLOW LINE OF GUTTERS, DRAINAGE STRUCTURES, DITCHES, ETC. SUCH THAT THE NATURAL FLOW LINE OF WATER IS OBSTRUCTED, THE LOOSE MATERIAL WILL BE REMOVED AT THE CLOSE OF EACH WORKING DAY. AT THE CONCLUSION OF CONSTRUCTION OPERATIONS, ALL DRAINAGE STRUCTURES AND FLOW LINES SHALL BE FREE FROM DIRT AND DEBRIS. THIS WORK SHALL BE CONSIDERED INCLUDED IN THE CONTRACT. THE CONTRACTOR'S FAILURE TO PROVIDE THE ABOVE WILL PRECLUDE ANY POSSIBLE ADDED COMPENSATION REQUESTED DUE TO DELAYS OR UNSUITABLE MATERIALS CREATED AS A RESULT THEREOF.
- THE CONTRACTOR SHALL VERIFY ALL DIMENSIONS AND EXISTING CONDITIONS AFFECTING THEIR WORK WITH THE ACTUAL CONDITIONS AT THE JOB SITE PRIOR TO ORDERING MATERIALS. IN ADDITION, THE CONTRACTOR MUST VERIFY THE LINE AND GRADES. IF THERE ARE ANY DISCREPANCIES FROM WHAT IS SHOWN ON THE CONSTRUCTION PLANS, STANDARD SPECIFICATIONS AND/OR SPECIAL DETAILS, THE CONTRACTOR SHALL SECURE WRITTEN INSTRUCTION FROM THE ENGINEER PRIOR TO PROCEEDING WITH ANY PART OF THE WORK AFFECTED BY OMISSION OR DISCREPANCIES. FAILING TO SECURE SUCH INSTRUCTION, THE CONTRACTOR WILL BE CONSIDERED TO HAVE PROCEEDED AT HIS/HER OWN RISK AND EXPENSE AND NO ADDITIONAL COMPENSATION WILL BE PROVIDED FOR ANY COSTS INCURRED.
- ALL PAVEMENT DIMENSIONS ARE SHOWN TO THE FACE OF CURB UNLESS OTHERWISE NOTED.
- WHERE SECTION OR SUBSECTION MONUMENTS ARE ENCOUNTERED, THE ENGINEER SHALL BE NOTIFIED BEFORE THE MONUMENTS ARE REMOVED. THE CONTRACTOR SHALL CAREFULLY PRESERVE ALL PROPERTY MARKS AND MONUMENTS UNTIL THE OWNER, AUTHORIZED SURVEYOR OR AGENT HAS WITNESSED OR OTHERWISE REFERENCED THEIR LOCATION.
- THE CONTRACTOR SHALL NOTIFY THE ENGINEER AT LEAST 72 HOURS PRIOR TO BEGINNING WORK.
- IF DURING CONSTRUCTION THE CONTRACTOR ENCOUNTERS OR OTHERWISE BECOMES AWARE OF ANY SEWERS OR UNDERDRAINS OTHER THAN THOSE SHOWN ON THE PLANS, HE/SHE SHALL INFORM THE ENGINEER, WHO SHALL DIRECT THE WORK NECESSARY TO MAINTAIN OR REPLACE THE FACILITIES IN SERVICE AND TO PROTECT THEM FROM DAMAGE DURING CONSTRUCTION IF MAINTAINED. EXISTING FACILITIES TO BE MAINTAINED THAT ARE DAMAGED BECAUSE OF NON-COMPLIANCE WITH THIS PROVISION SHALL BE REPLACED AT THE CONTRACTOR'S OWN EXPENSE.
- THE CONTRACTOR SHALL PROVIDE TEMPORARY TOILET FACILITIES AND HAND SANITIZING STATIONS FOR THE USE OF ALL THE CONTRACTORS PERSONNEL EMPLOYED ON THE WORK SITE. THE FACILITIES SHALL BE MAINTAINED IN PROPER SANITARY CONDITION THROUGHOUT THE PROJECT. THE LOCATION OF THE TEMPORARY FACILITIES SHALL BE APPROVED BY THE ENGINEER.
- THE CONTRACTOR MUST OBTAIN A FIRE HYDRANT PERMIT AND CITY-PROVIDED CART ASSEMBLY IN ORDER TO USE CITY WATER. FOR MORE INFORMATION, CONTACT THE WATER DEPARTMENT AT (847) 448-8216.
- IF ANY SOFT OR YIELDING MATERIALS ARE DETECTED AFTER EXCAVATION TO THE PROPOSED SUBGRADE, THE CONTRACTOR WILL, AT THE DIRECTION OF

- THE ENGINEER, REMOVE THE MATERIAL AND REPLACE IT WITH AGGREGATE BASE COURSE, TYPE B. THIS WORK WILL BE PAID FOR AT THE CONTRACT UNIT PRICE PER CUBIC YARD FOR "EARTH EXCAVATION" AND PER SQUARE YARD FOR "AGGREGATE BASE COURSE, TYPE B".
- CONSTRUCTION ACTIVITIES MAY OCCUR BETWEEN 7:00AM AND 5:00PM MONDAY THROUGH FRIDAY AND 8:00AM TO 4:00PM ON SATURDAYS (AS APPROVED BY THE ENGINEER). CONSTRUCTION ACTIVITIES ON SUNDAY ARE PROHIBITED. NO WORK WILL BE PERFORMED ON STATE OF ILLINOIS OBSERVED HOLIDAYS. CONSTRUCTION ACTIVITIES ARE IDENTIFIED AS THE OPERATION OF ANY EQUIPMENT, INCLUDING BUT NOT LIMITED TO THE WARMING UP OF ANY PIECE OF EQUIPMENT OR TURNING ON ENGINES. CONSTRUCTION ACTIVITIES SHALL NOT BEGIN BEFORE 7:00AM. ANY VIOLATION FOR WORKING HOURS CONTRACTOR WILL BE FINED \$500.00 FOR OCCURRENCE.
 - THE STORAGE OF EQUIPMENT AND/OR MATERIALS WITHIN THE PARKWAYS SHALL REQUIRE PRIOR APPROVAL OF THE ENGINEER.

PROJECT SPECIFIC NOTES

- THE CONTRACTOR SHALL PROVIDE AS-BUILT DRAWINGS THAT INCLUDE; CRITICAL SPOT GRADES SUCH AS OVERFLOW ELEVATIONS, SPOT ELEVATIONS ALONG THE DESIGNATED ADA ROUTE, SUFFICIENT INFORMATION SUCH THAT THE ENGINEER MAY VERIFY DETENTION VOLUMES, RIM AND INVERT ELEVATIONS OF ALL SEWERS, RIM AND TOP OF PIPE ELEVATIONS OF ALL WATER MAIN, LOCATIONS OF ALL INSTALLED UNDERGROUND UTILITIES, LOCATIONS OF ALL BURIED BENDS AND FITTINGS AND ALL FIELD CHANGES FROM THE APPROVED DRAWINGS.
- ALL CONSTRUCTION WILL BE INSPECTED BY THE OWNER'S REPRESENTATIVE. ALL WORK SHALL CONFORM TO THE REQUIREMENTS OF THE CITY OF EVANSTON AS WELL AS THE STANDARD SPECIFICATIONS.
- ALL PUBLIC WATER MAINS, STORM SEWERS AND SANITARY SEWER MAINS MUST BE ACCEPTED BY THE CITY OF EVANSTON.
- ALL ELEVATIONS ARE ON CITY OF EVANSTON VERTICAL DATUM. COE DATUM + 578.98 = NAVD88 DATUM.
- THE CONTRACTOR SHALL BE RESPONSIBLE FOR THE INSTALLATION AND MAINTENANCE OF ALL TRAFFIC CONTROL TO ADEQUATELY INFORM AND PROTECT THE PUBLIC OF ALL CONSTRUCTION OPERATIONS.
- PRIOR TO PLACEMENT OF PAVEMENT/STONE, THE SUBGRADE SHALL BE PROOF-ROLLED IN THE PRESENCE OF THE ENGINEER. PROOF-ROLLING SHALL BE DONE USING A THREE AXLE DUMP TRUCK TOGETHER WITH LOAD WEIGHING AT LEAST TWENTY-FIVE (25) TONS. THE LOAD SHALL BE UNIFORMLY PLACED IN THE DUMP BODY. ALL DEFICIENCIES SHALL BE REPAIRED AND RE-PROOF-ROLLED UNTIL FOUND ACCEPTABLE TO THE ENGINEER.
- ALL STONE USED ON THE PROJECT SHALL BE CRUSHED UNLESS SPECIFICALLY NOTED OTHERWISE.
- ALL CONNECTIONS TO EXISTING COMBINED SEWER OR SANITARY SEWER MANHOLES SHALL BE INSTALLED WITH A NEOPRENE BOOT SECURED WITH DOUBLE STAINLESS STEEL STRAPS MEETING THE REQUIREMENTS OF ASTM C-923.
- ALL CONCRETE SHALL HAVE AN IDOT TYPE 3 MEMBRANE CURING COMPOUND APPLIED TO THE SURFACE WITHIN 1 HOUR OF FINAL STRIKING AT THE MANUFACTURER RECOMMENDED APPLICATION RATE.
- ALL DOWEL BARS AND TIE BARS SHALL BE EPOXY COATED UNLESS NOTED OTHERWISE.
- ALL PAVEMENT SUBGRADE SHALL BE COMPACTED TO 95% MODIFIED PROCTOR DENSITY. ALL SUBGRADE IN LAWN AREAS SHALL BE COMPACTED TO 90% MODIFIED PROCTOR DENSITY.
- SPREAD SCREENED TOPSOIL ON ALL DISTURBED AREAS AND PROPOSED GREEN AREAS. TOPSOIL SHALL COMPLY WITH REQUIREMENTS OF ARTICLE 1081.05.

HOT-MIX ASPHALT MIXTURE REQUIREMENTS	
MIXTURE TYPE	AIR VOIDS @ Ndes
PAVEMENT PATCHING	
HOT-MIX ASPHALT SURFACE COURSE, MIX 'D', N50 (IL 9.5 mm)	4% @ 50 GYR
HOT-MIX ASPHALT BINDER COURSE, IL-19.0, N50	4% @ 50 GYR
FULL DEPTH PAVEMENT	
HOT-MIX ASPHALT SURFACE COURSE, MIX 'D', N50 (IL 9.5 mm)	4% @ 50 GYR
HOT-MIX ASPHALT BINDER COURSE, IL-19.0, N50	4% @ 50 GYR

THE UNIT WEIGHT TO CALCULATE ALL HMA SURFACE MIXTURE QUANTITIES IS 112 LBS/SY/IN

THE "AC TYPE" FOR NON-POLYMERIZED HMA SHALL BE "PG 64-22" UNLESS OTHERWISE MODIFIED BY DISTRICT ONE SPECIAL PROVISIONS. FOR "PERCENT OF RAP" SEE DISTRICT ONE SPECIAL PROVISIONS.

**SUMMARY OF QUANTITIES
FOSTER STREET SIDEWALK GAP INFILL**

Item No.	Item	Unit	Quantity
1	TREE TRUNK PROTECTION	EACH	2
2	TREE ROOT PRUNING	FOOT	80
3	EARTH EXCAVATION	CU YD	90
4	TOPSOIL FURNISH AND PLACE, 4"	SQ YD	565
5	SODDING, SALT TOLERANT	SQ YD	565
6	AGGREGATE BASE COURSE, TYPE B 4"	SQ YD	266
7	INCIDENTAL HOT-MIX ASPHALT SURFACING	TON	5
8	PORTLAND CEMENT CONCRETE DRIVEWAY PAVEMENT, 6 INCH	SQ YD	28
9	PORTLAND CEMENT CONCRETE DRIVEWAY PAVEMENT, 8 INCH	SQ YD	120
10	PORTLAND CEMENT CONCRETE SIDEWALK, 5 INCH	SQ FT	4,270
11	DETECTABLE WARNINGS	SQ FT	180
12	HOT-MIX ASPHALT SURFACE REMOVAL, 1.5"	SQ YD	36
13	DRIVEWAY PAVEMENT REMOVAL	SQ YD	148
14	COMBINATION CURB AND GUTTER REMOVAL	FOOT	130
15	SIDEWALK REMOVAL	SQ FT	2,215
16	COMBINATION CONCRETE CURB AND GUTTER, TYPE B-6.12	FOOT	146
17	CHAIN LINK FENCE REMOVAL AND REPLACEMENT, 4-FOOT	FOOT	100
18	CHAIN LINK FENCE DOUBLE SWING GATE, 12-FEET	EACH	1
19	NON-SPECIAL WASTE DISPOSAL	CU YD	90
20	SPECIAL WASTE PLANS AND REPORTS	LSUM	1
21	SOIL DISPOSAL ANALYSIS	EACH	2
22	MOBILIZATION	LSUM	1
23	TRAFFIC CONTROL AND PROTECTION	LSUM	1
24	THERMOPLASTIC PAVEMENT MARKING - LINE 6"	FOOT	50
25	THERMOPLASTIC PAVEMENT MARKING - LINE 24"	FOOT	12
26	STREET SWEEPING	EACH	2
27	CONSTRUCTION LAYOUT	LSUM	1

**SUMMARY OF QUANTITIES
CDBG SIDEWALK IMPROVEMENTS**

Item No.	Item	Unit	Quantity
1	EARTH EXCAVATION	CU YD	50
2	TOPSOIL FURNISH AND PLACE, 4"	SQ YD	500
3	SODDING, SALT TOLERANT	SQ YD	500
4	AGGREGATE BASE COURSE, TYPE B 4"	SQ YD	50
5	INCIDENTAL HOT-MIX ASPHALT SURFACING	TON	10
6	PORTLAND CEMENT CONCRETE DRIVEWAY PAVEMENT, 6 INCH	SQ YD	50
7	PORTLAND CEMENT CONCRETE DRIVEWAY PAVEMENT, 8 INCH	SQ YD	50
8	PORTLAND CEMENT CONCRETE SIDEWALK, 5 INCH	SQ FT	5,000
9	DETECTABLE WARNINGS	SQ FT	120
10	HOT-MIX ASPHALT SURFACE REMOVAL, 1.5"	SQ YD	45
11	DRIVEWAY PAVEMENT REMOVAL	SQ YD	100
12	CURB REMOVAL	FOOT	100
13	COMBINATION CURB AND GUTTER REMOVAL	FOOT	100
14	SIDEWALK REMOVAL	SQ FT	5,000
15	CONCRETE CURB, TYPE B	FOOT	100
16	COMBINATION CONCRETE CURB AND GUTTER, TYPE B-6.12	FOOT	100
17	BRICK PAVER REMOVAL AND REPLACEMENT	SQ FT	50



DATE	NO.	REVISION
	4	
	3	
	2	
	1	

**2022 CDBG SIDEWALK IMPROVEMENTS AND GAP INFILL
GENERAL NOTES AND SUMMARY OF QUANTITIES**

SCALE	BID NUMBER:	ISSUED FOR:	DESIGNED BY:	SHEET 2 OF 5
HORIZONTAL N/A	22-27	CONSTRUCTION	BN	
VERTICAL N/A		DATE: 03/18/2022	CHECKED BY: CV	

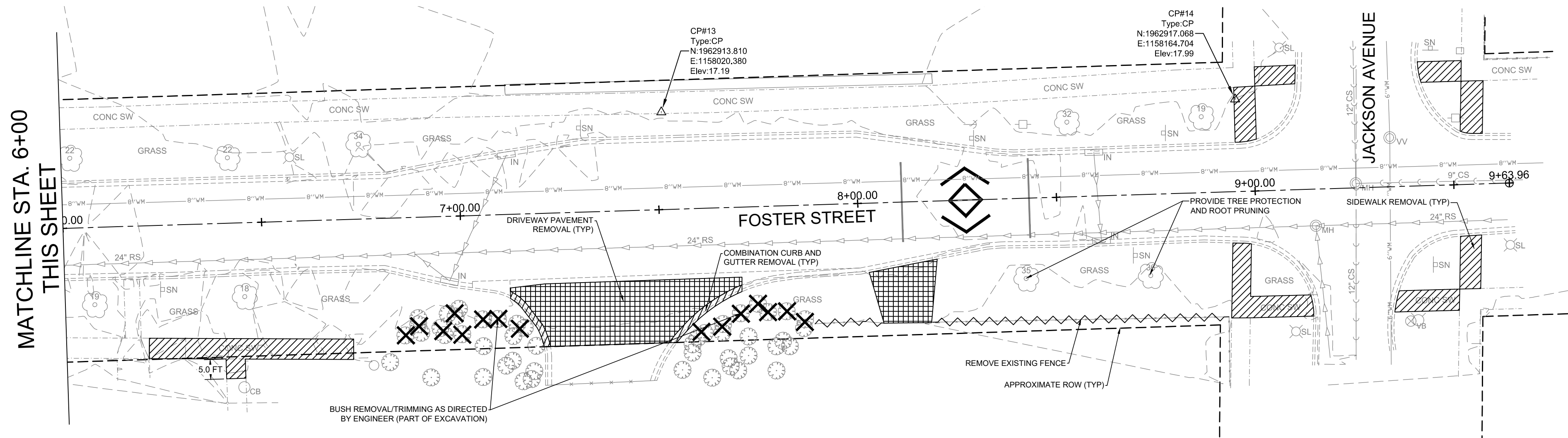
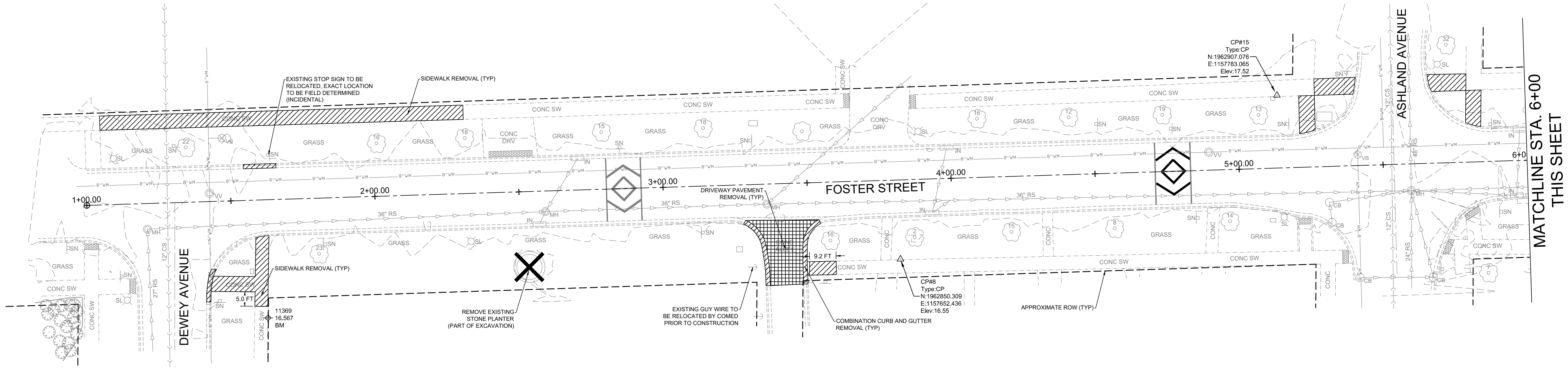
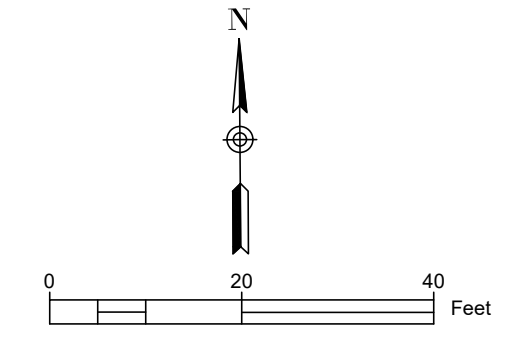

NOTES:

1. THE EXACT LOCATION OF ALL UTILITIES SHALL BE VERIFIED BY THE CONTRACTOR. CONTACT J.U.L.I.E. AT 1-800-892-0123 FOR UTILITY LOCATES PRIOR TO CONSTRUCTION.
2. THE RIGHT-OF-WAY (ROW) SHOWN ON THE PLANS IS APPROXIMATE. CONTRACTOR SHALL IDENTIFY AND STAKE THE EXACT LOCATION OF THE ROW PRIOR TO STARTING CONSTRUCTION. THIS WORK SHALL BE INCLUDED IN THE COST FOR "CONSTRUCTION LAYOUT."
3. CONTRACTOR SHALL REMOVE EVERYTHING NECESSARY TO COMPLETE CONSTRUCTION INCLUDING ALL NECESSARY CLEARING AND GRUBBING. LABELS ARE FOR CONVENIENCE ONLY. THE CONTRACTOR SHALL VERIFY REMOVALS PRIOR TO SUBMITTING A BID FOR WORK ON THIS PROJECT. THIS WORK WILL NOT BE PAID FOR SEPARATELY BUT SHALL BE INCLUDED IN THE COST FOR "EARTH EXCAVATION."
4. EXACT LIMITS OF REMOVALS SHALL BE FIELD VERIFIED WITH THE RESIDENT ENGINEER PRIOR TO CONSTRUCTION.
6. AT THE DIRECTION OF THE RESIDENT ENGINEER, ANY ASPHALT PATCHING ALONG CURB AND GUTTER REMOVAL AND REPLACEMENT LIMITS SHALL BE PAID FOR AS "INCIDENTAL HOT MIX ASPHALT SURFACING."

X:\Public Works\Engineering\Engineers\FY 2022 PROJECTS\CDBG Sidewalk Improvements and Gap Infill\CAD\Sheet Files\3. EXISTING AND DEMO.dwg

4		
3		
2		
1		
DATE	NO.	REVISION

**2022 CDBG SIDEWALK IMPROVEMENTS AND GAP INFILL
EXISTING CONDITIONS AND DEMO PLAN**

SCALE	
HORIZONTAL	1" = 20'
VERTICAL	N/A

BID NUMBER: 22-27

ISSUED FOR: CONSTRUCTION
DATE: 03/18/2022

DESIGNED BY: BN
DRAWN BY: BN
CHECKED BY: CV

X:\Public Works\Engineering\Engineers\FY 2022 PROJECTS\CDBG Sidewalk Improvements and Gap Infill\CAD\Sheet Files\4. SITE PLAN.dwg

MATCHLINE STA. 6+00
THIS SHEET

MATCHLINE STA. 6+00
THIS SHEET

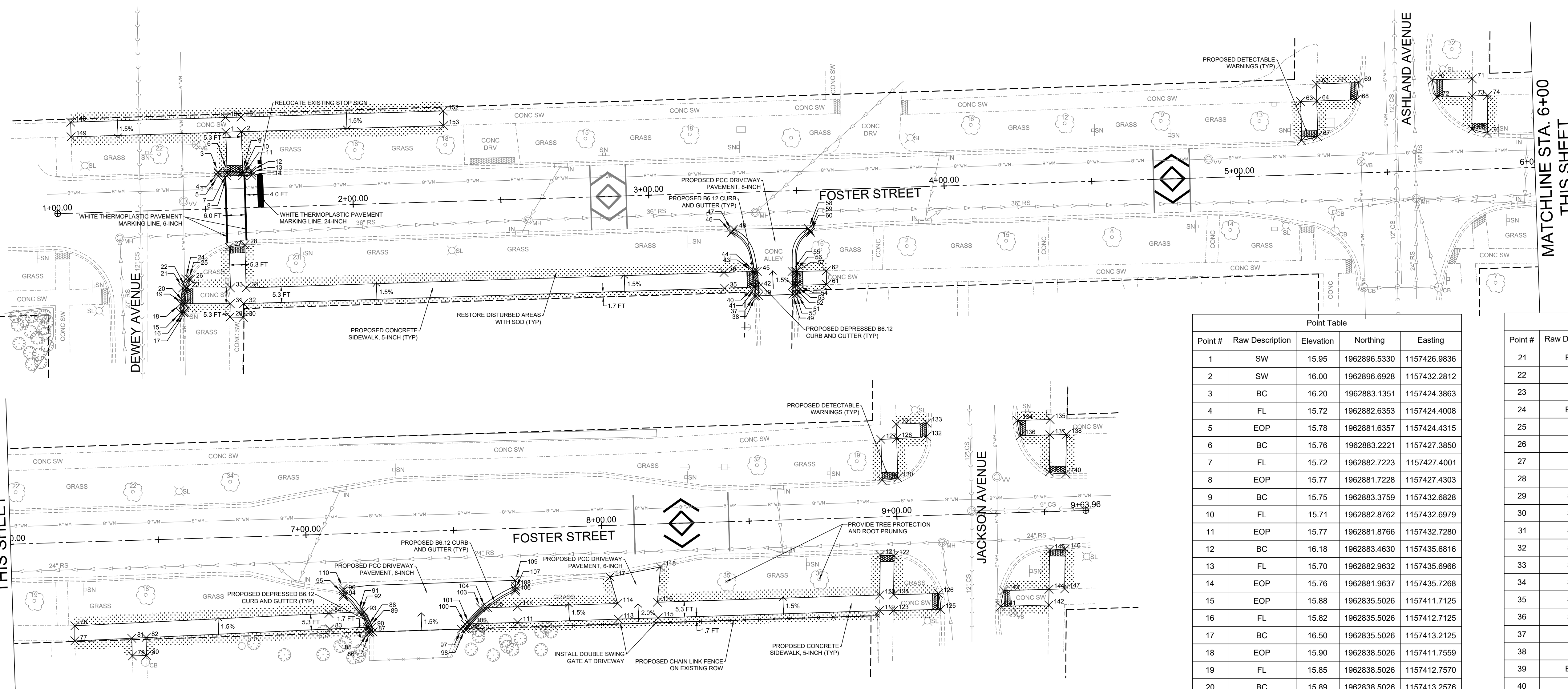

Point #	Raw Description	Elevation	Northing	Easting
41	FL	16.32	1962844.0975	1157606.1787
42	EOP	16.40	1962844.1264	1157607.1783
43	BC	16.31	1962849.3668	1157605.2485
44	FL	16.27	1962849.3830	1157605.7507
45	EOP	16.32	1962849.4155	1157606.7551
46	BC	15.84	1962862.4325	1157597.9820
47	FL	15.76	1962862.8654	1157598.2430
48	EOP	15.67	1962863.7299	1157598.7642
49	EOP	16.55	1962841.7045	1157618.8517
50	FL	16.49	1962841.7263	1157619.8516
51	BC	16.60	1962841.7372	1157620.3515
52	EOP	16.32	1962844.7027	1157618.7343
53	FL	16.27	1962844.7245	1157619.7342
54	BC	16.31	1962844.7354	1157620.2341
55	EOP	16.24	1962849.3671	1157618.5628
56	FL	16.19	1962849.3889	1157619.5630
57	BC	16.23	1962849.3846	1157620.0630
58	EOP	15.58	1962863.9926	1157624.1365
59	FL	15.73	1962863.0977	1157624.5829
60	BC	15.81	1962862.6503	1157624.8061

Point #	Raw Description	Elevation	Northing	Easting
61	SW	16.58	1962844.9534	1157630.2333
62	SW	16.54	1962849.6193	1157630.1315
63	SW	16.29	1962906.9023	1157790.5877
64	SW	16.29	1962907.0801	1157796.0377
65	SW	16.29	1962912.7983	1157795.8828
66	BC	15.70	1962893.7776	1157790.9345
67	BC	15.77	1962895.0744	1157796.3550
68	BC	15.82	1962907.5176	1157809.4540
69	BC	15.85	1962913.3555	1157810.2863
70	BC	15.84	1962914.3211	1157835.0724
71	SW	16.50	1962914.5654	1157848.6526
72	BC	15.77	1962908.4062	1157836.7002
73	SW	16.41	1962908.7945	1157848.6035
74	SW	16.44	1962908.9666	1157853.8829
75	BC	15.78	1962897.6286	1157848.5086
76	BC	15.71	1962896.2519	1157853.7748
77	SW	18.04	1962851.8656	1157891.6305
78	SW	18.03	1962856.9968	1157891.6515
79	SW	17.97	1962846.7931	1157911.0982
80	SW	17.92	1962846.9563	1157915.9277

Point #	Raw Description	Elevation	Northing	Easting
81	SW	17.93	1962852.7558	1157910.8968
82	SW	17.88	1962852.9957	1157915.7237
83	SW	17.25	1962855.9097	1157977.8516
84	SW	17.17	1962861.1809	1157977.5949
85	BC	17.60	1962854.8498	1157990.9394
86	FL	17.18	1962854.8678	1157991.4971
87	EOP	17.24	1962854.9005	1157992.5099
88	BC	17.16	1962856.5035	1157990.5109
89	FL	17.12	1962856.5301	1157991.0782
90	EOP	17.17	1962856.5783	1157992.1069
91	BC	17.08	1962861.6676	1157987.5925
92	FL	17.04	1962861.7004	1157988.2651
93	EOP	17.09	1962861.7599	1157989.4881
94	BC	16.97	1962866.9706	1157982.4987
95	FL	16.49	1962867.6195	1157982.4702
96	EOP	16.55	1962868.7721	1157982.4197
97	EOP	17.24	1962855.8644	1158022.3633
98	FL	17.18	1962855.9054	1158023.6335
99	BC	17.60	1962855.9283	1158024.3427
100	EOP	17.17	1962857.5741	1158023.6714

Point #	Raw Description	Elevation	Northing	Easting
101	FL	17.12	1962857.6175	1158025.0136
102	BC	17.16	1962857.6418	1158025.7665
103	EOP	17.09	1962863.0444	1158028.8584
104	FL	17.04	1962863.0957	1158030.4468
105	BC	17.08	1962863.1248	1158031.3479
106	BC	17.31	1962868.7193	1158040.6640
107	FL	17.21	1962869.3173	1158040.6664
108	EOP	16.97	1962870.4008	1158040.6709
109	EOP	16.75	1962872.3630	1158040.6790
110	EOP	16.44	1962869.6151	1157982.3827
111	SW	17.74	1962858.1502	1158041.5137
112	SW	17.66	1962863.4475	1158041.3427
113	SW	17.76	1962859.2468	1158075.4753
114	SW	17.65	1962864.5440	1158075.3043
115	SW	17.76	1962859.6830	1158088.9838
116	SW	17.65	1962864.9768	1158088.7085
117	BC	16.94	1962873.5211	1158072.6682
118	BC	17.15	1962876.8935	1158089.7515
119	SW	17.85	1962862.0997	1158163.8335
120	SW	17.77	1962867.4051	1158163.9158

Point #	Raw Description	Elevation	Northing	Easting
121	BC	17.14	1962880.9340	1158164.1257
122	BC	17.09	1962880.7018	1158168.7966
123	SW	17.85	1962862.1150	1158168.5082
124	SW	17.77	1962867.4787	1158168.5914
125	BC	16.86	1962862.5596	1158184.4664
126	BC	16.91	1962867.9008	1158183.7418
127	SW	18.09	1962920.0544	1158164.3107
128	SW	18.02	1962920.3687	1158169.6413
129	BC	17.33	1962906.2420	1158164.7059
130	BC	17.33	1962907.0345	1158170.0228
131	SW	18.04	1962925.2285	1158169.5022
132	BC	17.60	1962920.9622	1158179.7066
133	BC	17.60	1962925.6486	1158179.8108
134	BC	17.71	1962926.4882	1158210.4765
135	SW	17.79	1962926.7969	1158221.5567
136	BC	17.70	1962921.3224	1158211.4119
137	SW	17.78	1962921.6028	1158221.4762
138	SW	17.82	1962921.7586	1158227.0657
139	BC	17.65	1962909.0529	1158221.2815
140	BC	17.30	1962908.4904	1158226.8599

Point #	Raw Description	Elevation	Northing	Easting
141	BC	17.34	1962863.5697	1158204.8531
142	SW	17.87	1962864.0224	1158221.1011
143	BC	17.35	1962868.9193	1158205.9516
144	SW	17.87	1962869.3436	1158221.1837
145	BC	17.28	1962862.6270	1158221.3897
146	BC	17.25	1962862.9656	1158226.6787
147	SW	17.80	1962869.4909	1158226.4697
148	SW	16.03	1962899.9163	1157374.5051
149	SW	16.04	1962894.9548	1157374.6548
150	SW	16.02	1962901.4945	1157426.8340
151	SW	16.07	1962901.6542	1157432.1316
152	SW	16.17	1962903.7180	1157500.5606
153	SW	16.09	1962898.7565	1157500.7102

ABBREVIATIONS:
 EOP: EDGE OF PAVEMENT
 FL: FLOWLINE
 SW: SIDEWALK
 BC: BACK OF CURB



DATE	NO.	REVISION
	4	
	3	
	2	
	1	

2022 CDBG SIDEWALK IMPROVEMENTS AND GAP INFILL SITE PLAN

SCALE	BID NUMBER:	22-27
HORIZONTAL 1" = 20'		
VERTICAL N/A		

ISSUED FOR: CONSTRUCTION	DESIGNED BY: BN	SHEET 4 OF 5
DATE: 03/18/2022	DRAWN BY: BN	
	CHECKED BY: CV	

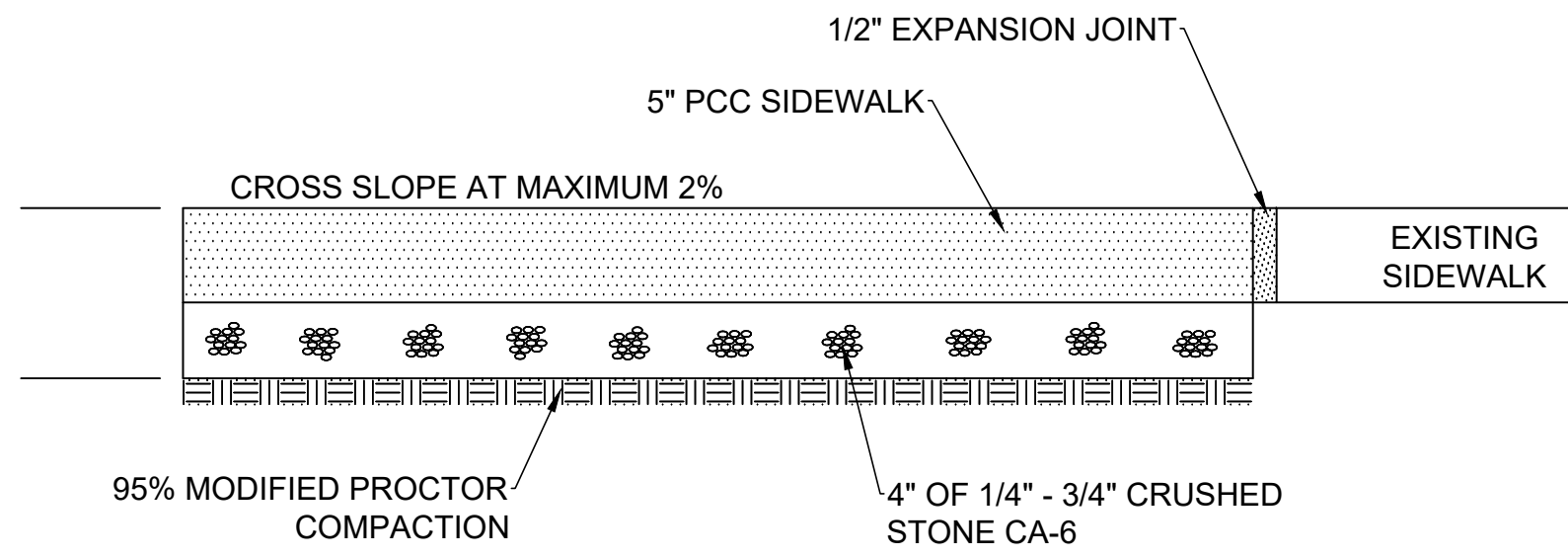

NOTES:

1. SET 1/2" EXPANSION JOINTS AT POINTS ABUTTING CURB OR PAVEMENT AND AT 45' MAX. INTERVALS.
2. CONTROL JOINTS SHALL BE 1/8" TO 1/4" WIDE AND 1/4 OF THE SIDEWALK THICKNESS DEEP. THE EDGE OF THE CONTROL JOINTS SHALL BE GIVEN A 1/4" RADIUS.
3. SIDEWALK WIDTH IS AS SHOWN ON PLANS.
4. THICKNESS THROUGH DRIVEWAYS AS SHOWN ON PLANS.

D PCC SIDEWALK
NOT TO SCALE

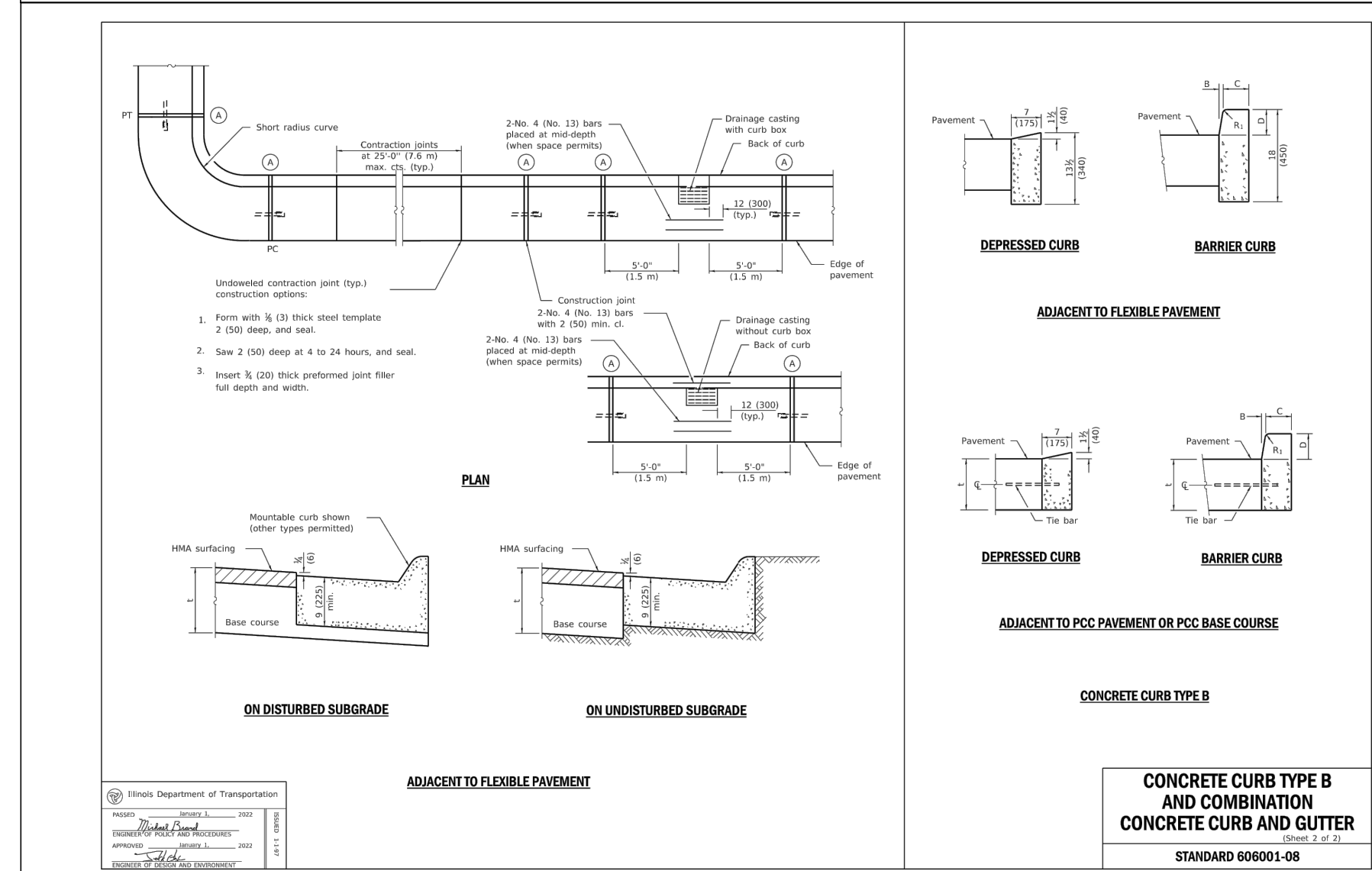
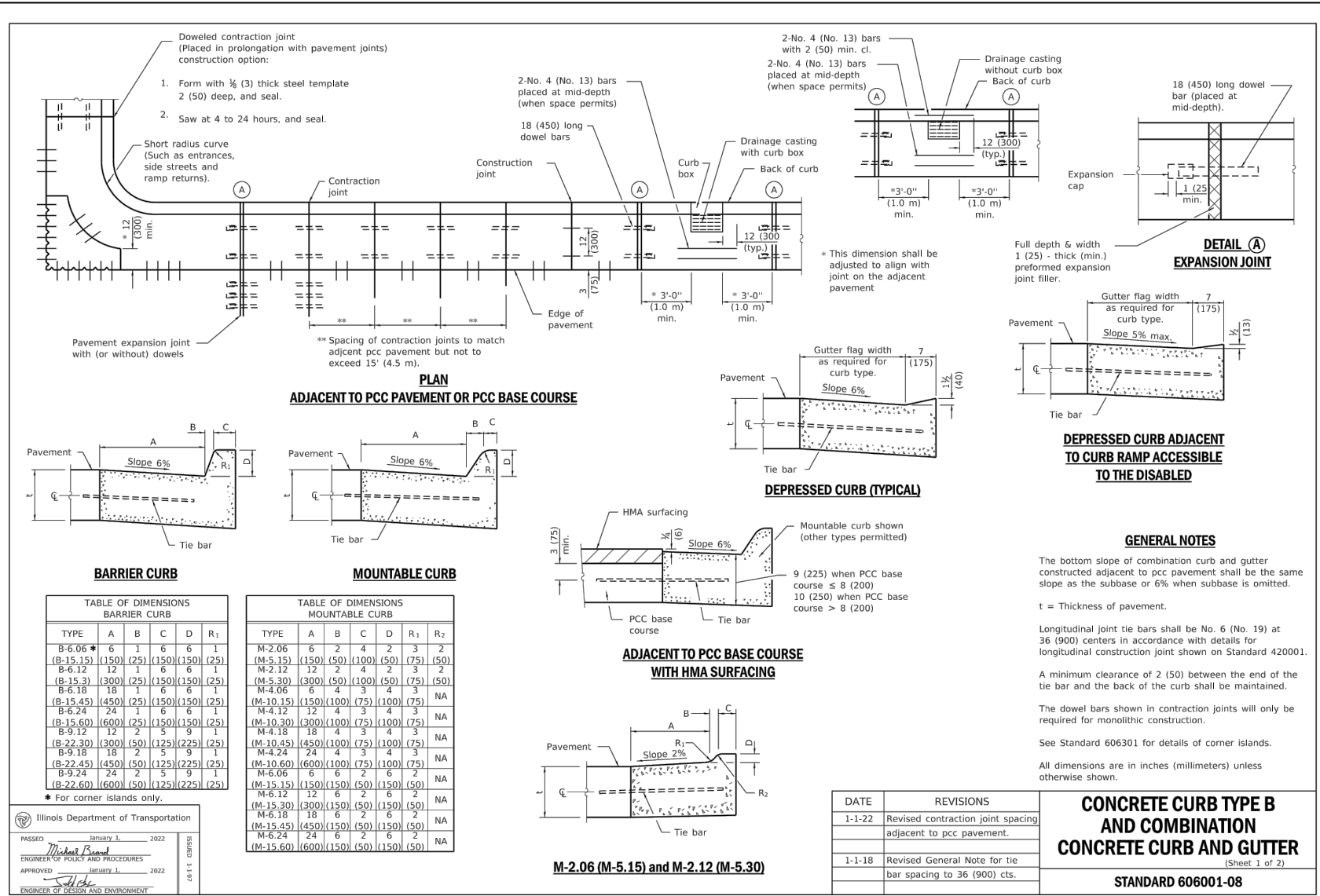
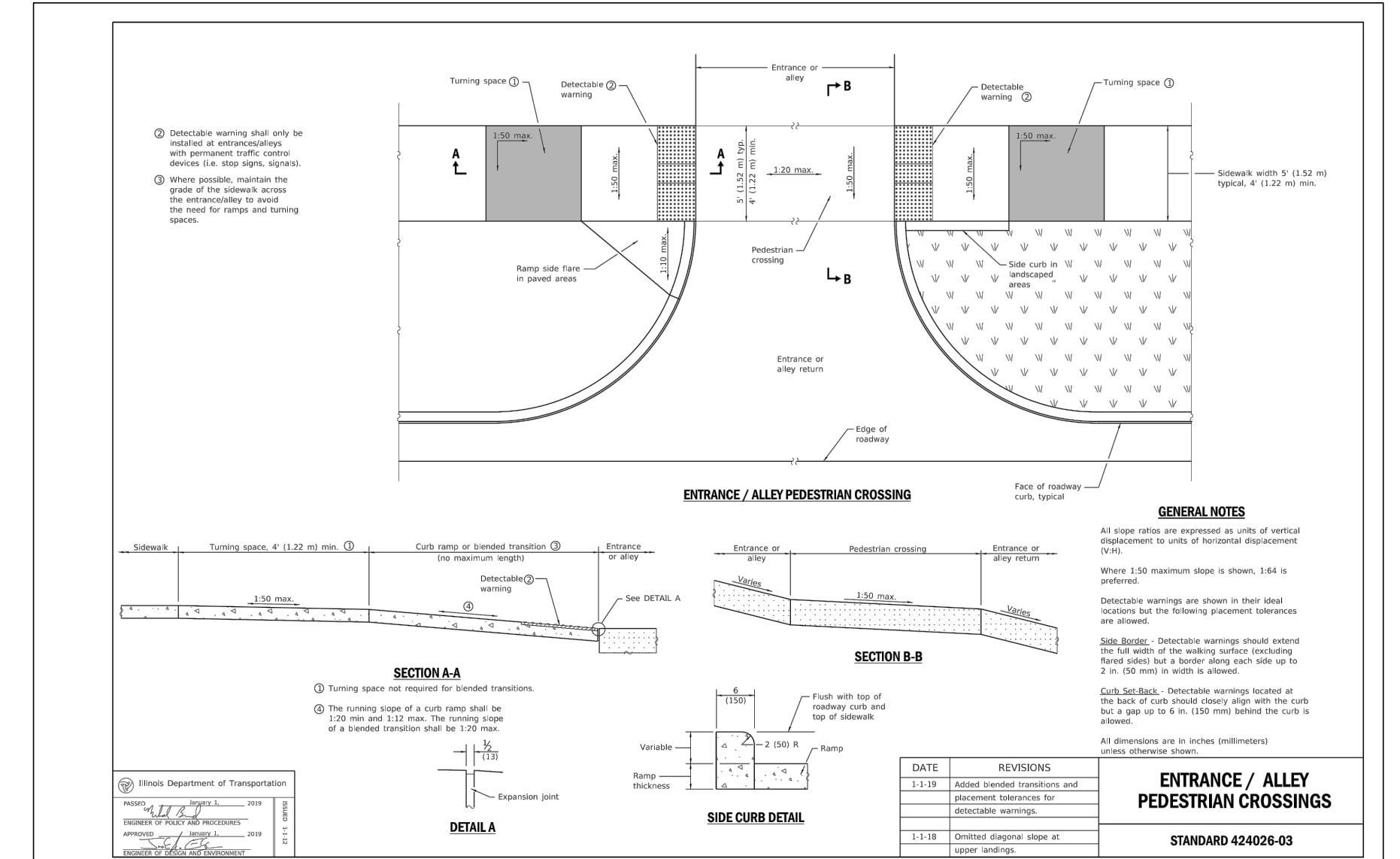
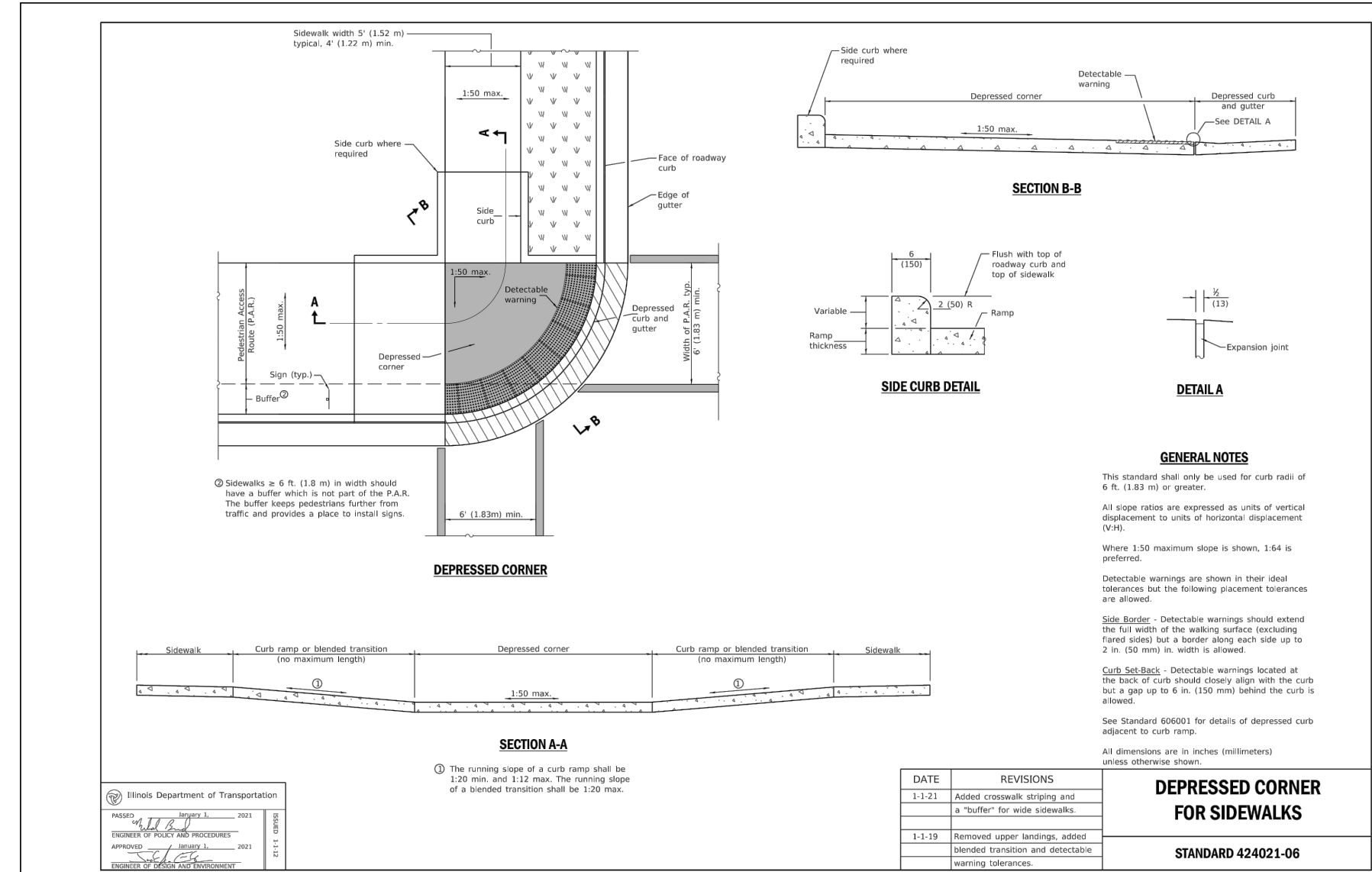
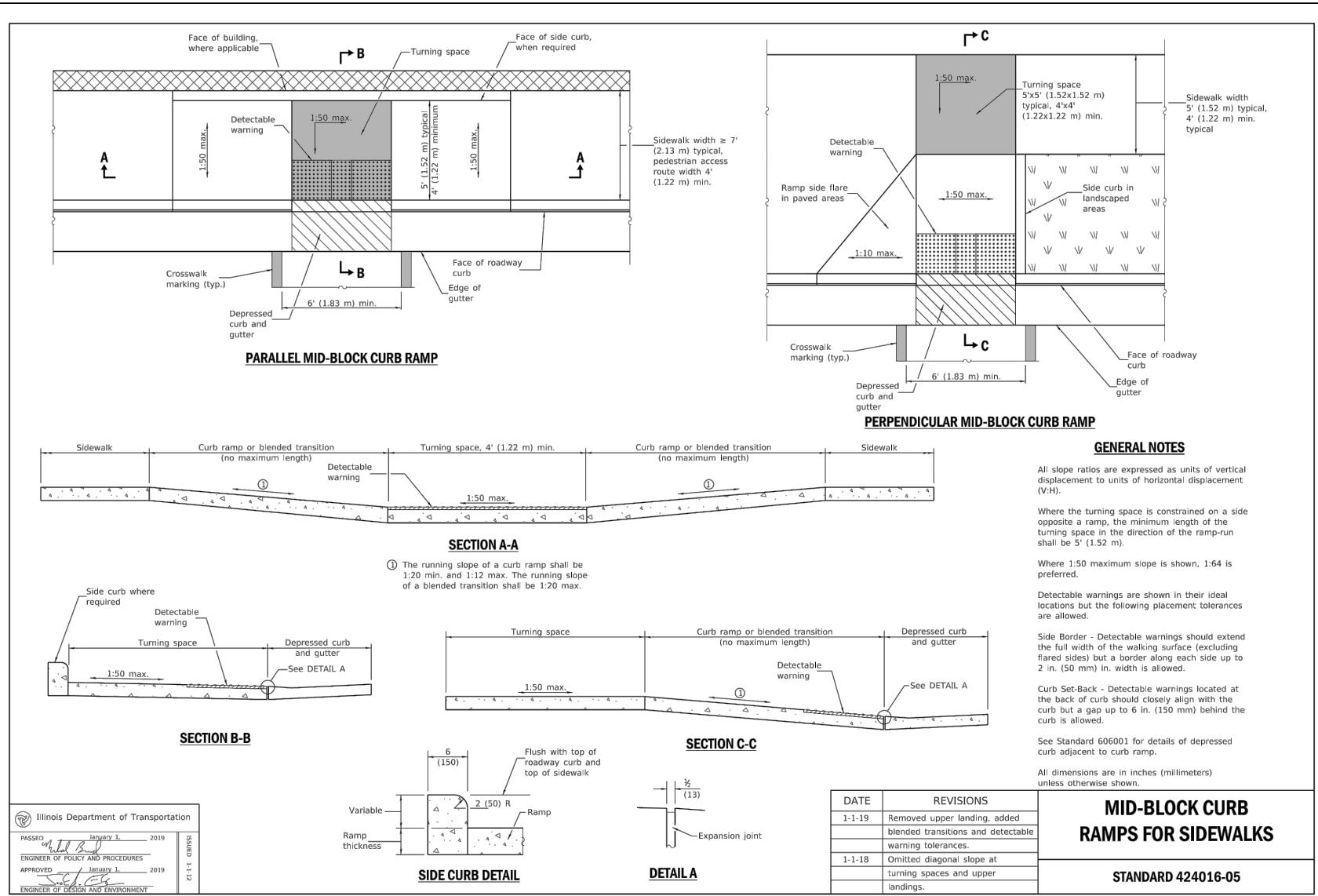
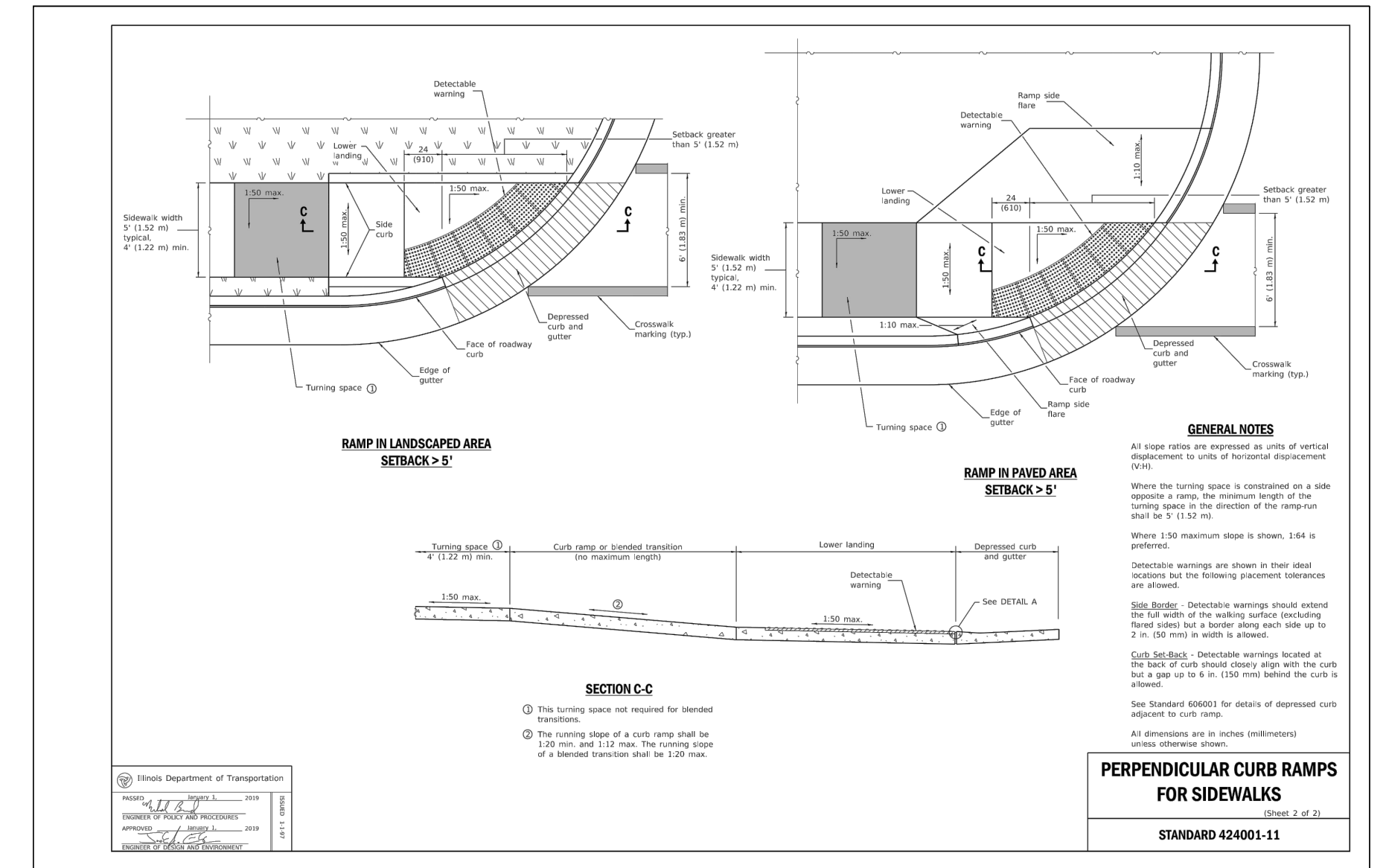
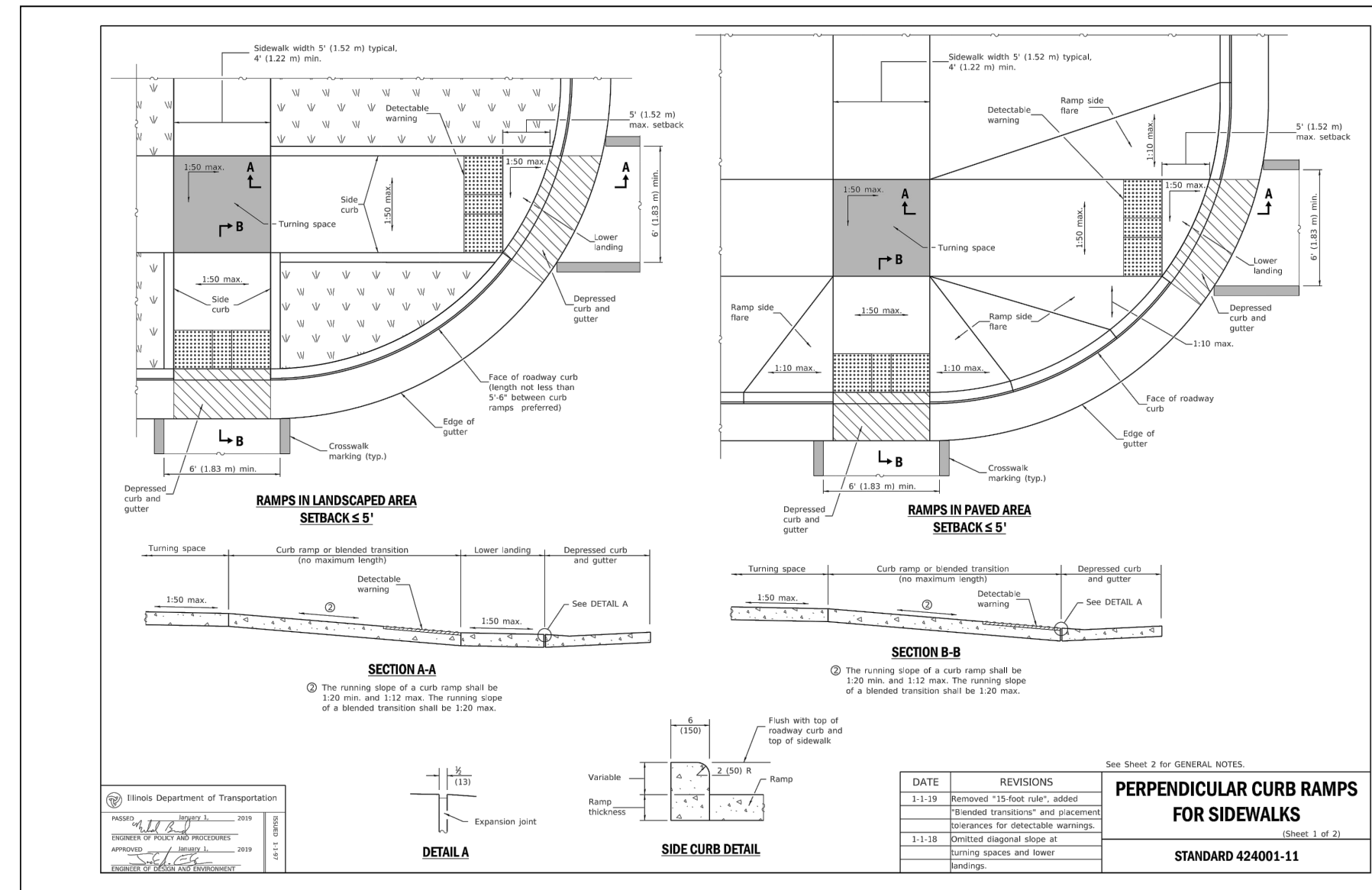

X:\Public\Works\Engineering\Engineers\FY 2022\PROJECTS\CDGB Sidewalk Improvements and Gap Infill\CAD\Sheet Files\5_DETAILS.dwg

DATE	NO.	REVISION
	4	
	3	
	2	
	1	

2022 CDBG SIDEWALK IMPROVEMENTS AND GAP INFILL DETAILS

SCALE
HORIZONTAL NTS
VERTICAL N/A

BID NUMBER:	22-27
ISSUED FOR:	CONSTRUCTION
DATE:	03/18/2022

DESIGNED BY:	BN	SHEET 5 OF 5
DRAWN BY:	BN	
CHECKED BY:	CV	

Registering for DemandStar



We are pleased to announce our membership in the DemandStar network. DemandStar is an online marketplace that connects our suppliers directly to the bids, quotes and RFPs that matter to them.

DemandStar is open and accessible to all businesses and provides instant access to our solicitations. By registering for your complimentary DemandStar account, you will receive:

- **Instant** access to bids, quotes and RFPs
- **Automatic** notifications, right to you inbox, of bids that match the commodity codes you select
- The ability to **quickly view** the contractual terms and scope of work
- All the **forms and documents** you need in one place
- Access to **more government bids** in neighboring cities, counties and states

It's EASY! Get started with these 3 easy steps!

1 REGISTER

Go to:

<https://www.demandstar.com/registration>

Create an Account with DemandStar

You are one step away from picking your free government agency

Email Address

Company Name

I accept the DemandStar [Terms of Use](#) and [Privacy Policy](#)

Next



2 CHOOSE YOUR FREE AGENCY

Type in the name of the government agency you'd like to add, for example "City of Metropolis" in the Search Box

3 CHECK OUT

Check out with your **FREE AGENCY** Registration by clicking "Skip for now" on the page where it gives you options to add additional counties and States

← Choose Your Free Agency

Receive full access to the government agency of your choice and receive advance notifications of new opportunities.

City of Metropolis ✕

Narrow down your search by selecting a state and county.

State	County
Select State ▼	Select County ▼

- City of Metropolis – Board of Commisioners
- City of Metropolis Purchasing
- Metropolis Technical College

You have chosen **Metropolis Technical College** as your free agency.
Add additional government agencies below for \$25 per County,
Statewide and National subscriptions available.

My Subscriptions  [0]

Nation (0)

States (0)

Counties (0)

		Your Current Rate
Total	(0 subscriptions)	\$0/year

Proceed to Checkout

Skip for Now

SIGN UP

Visit www.demandstar.com





DEMANDSTAR

B u i l d i n g C o m m u n i t i e s .

(E-bidding) Electronic Bidding Instructions

Introduction

To submit a bid electronically (e-bidding) on DemandStar

- The project **MUST** be setup for e-bidding by the government agency advertising the opportunity

Bid Identifier	Agency Name	Bid Status	Broadcast Date	Date Due ▼	Name	Actions
RFP-2019-01-0-2019/df	Town of Malabar	Active	5/15/2019	5/31/2019	Malabar Parks and Recreation Board Memorial Wall Project	Planholders, Download/Order, Details
EBID-20190077-0-2019/HF	City of Port St. Lucie, Procurement Management Department	Active	4/25/2019	5/31/2019	Purchase Breaching "Backpack" Gas Masks and Gas Mask Cartridges for the Police Department JAG Grant Funded	E-Bidding, Planholders, Download/Order, Details



How to check if it is an e-bidding opportunity

- Not all opportunities posted on DemandStar by government are available for e-bidding
- Those that are available for you to electronically bid will list "e-bidding" as an available "ACTION" when you look at the project details

In order to do
e-bidding

1. Click on “E-bidding” in
the actions column

Bid Identifier	Agency Name	Bid Status	Broadcast Date	Date Due ▼	Name	Actions
RFP-2019-01-0-2019/df	Town of Malabar	Active	5/15/2019	5/31/2019	Malabar Parks and Recreation Board Memorial Wall Project	Planholders, Download/Order, Details
EBID-20190077-0-2019/HF	City of Port St. Lucie, Procurement Management Department	Active	4/25/2019	5/31/2019	Purchase Breaching “Backpa Gas Masks and Gas Mask Cartridges for the Police Department JAG Grant Funded	E-Bidding, Planholders, Download/Order, Details



In order to do
e-bidding

2. Enter your contact information and enter in all required fields

Note: You **MUST** put a number of the “BID AMOUNT” box. However, that number can be 0 so as to allow for a more detailed description of your bid through your uploaded documents.

Contact Information

**indicates required fields*

Company Name *

Address 1 *

Address 2

City *

State *

Postal Code *

Phone *

Fax

Country *

 Bid Amount *

Alternate Bid Amount

Notes

In order to do e-bidding

- In the agency required documents section – check the documents you intend on uploading and fulfilling. By checking these boxes this is **ONLY** an acknowledgement of how you will fulfill the requirement. You still have to upload the documents.

Required Documents



The following documents are required by the agency for this project. Please select which documents you will be submitting electronically (online) and which ones you will submit directly to the agency (offline).

Agency Required Documents

Document	None	Online/ Electronic	Offline/ Manual	Not submitting
-	❗	✓	📄	•
Bid Reply	<input type="radio"/>	<input checked="" type="radio"/>	<input type="radio"/>	<input type="radio"/>
Checklist	<input type="radio"/>	<input checked="" type="radio"/>	<input type="radio"/>	<input type="radio"/>
Subcontractor List	<input type="radio"/>	<input checked="" type="radio"/>	<input type="radio"/>	<input type="radio"/>
Current Workload, List of Projects and Completion Dates	<input type="radio"/>	<input checked="" type="radio"/>	<input type="radio"/>	<input type="radio"/>
Questionnaire	<input checked="" type="radio"/>	<input type="radio"/>	<input type="radio"/>	<input type="radio"/>
Drug Free Workplace Form	<input checked="" type="radio"/>	<input type="radio"/>	<input type="radio"/>	<input type="radio"/>

In order to do e-bidding

Upload your response documents in an accepted file format

Make sure that you have covered and uploaded all the required documents

E-Bid Response Documents

Agency Name	City of Port St. Lucie, Procurement Management Department
Bid Number	EBID-20190077-0-2019/HF
Bid Name	Purchase Breaching "Backpack" Kits, Gas Masks and Gas Mask Cartridges for the Police Department JAG Grant Funded
Bid Due Date	5/31/2019 3:00:00 PM Eastern time
Bid Opening	14 days, 21 hours, 45 minutes, 5 seconds

No response documents uploaded

Agency Accepted File Formats



Formats

Adobe Acrobat (*.PDF)
Microsoft Excel (*.XLS)
Microsoft Excel (*.XLSX)
Microsoft PowerPoint (*.PPT)
Microsoft Word (*.DOC)
Microsoft Word (*.DOCX)

Upload Electronic Documents

** indicates required fields*



Document Title *

Specify Upload Document *

Choose File No file chosen

(Type the path of the document, or click the Browse button.)

Upload

In order to do e-bidding

Once you decide you've uploaded all your documents that you would like to submit, make sure you click the **NEXT** button at the bottom of the screen

E-Bid Response Documents

Agency Name City of Port St. Lucie, Procurement Management Department
Bid Number EBID-20180218-0-2018/jer
Bid Name Sculpture on Lawn at City Hall Temporary Art Installation
Bid Due Date 1/9/2019 2:00:00 PM Eastern time
Bid Opening 100 days, 1 hour, 20 minutes, 11 seconds

	Document Title	Format	Size	Uploaded	Status	Action
1	 E-Bidding for Suppliers	Microsoft Word	12 Kb	10/1/2018 9:39:50 AM	Complete	View , Remove

Agency Accepted File Formats

Formats
Adobe Acrobat (*.PDF)
Microsoft Excel (*.XLS)
Microsoft Excel (*.XLSX)
Microsoft PowerPoint (*.PPT)
Microsoft Word (*.DOC)
Microsoft Word (*.DOCX)

Upload Electronic Documents

* indicates required fields

Document Title *

Specify Upload Document *

(Type the path of the document, or click the Browse button.)

Your document has successfully uploaded but your response is not yet complete. You must still click 'Submit Response' on Bid Response Details page in order to complete your response and receive a confirmation

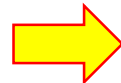

Completing your e-bid submittal

- Please **VERIFY** that you have attached **ALL** the required documents
- Click on the **Submit Response** button to complete your e-bid

Agency Required Documents

EDIT

1. **Bid Reply** (Electronic/Online) ✓
2. **Checklist** (Electronic/Online) ✓
3. **Subcontractor List** (Electronic/Online) ✓
4. **Current Workload, List of Projects and Completion Dates** (Electronic/Online) ✓
5. **Questionnaire** (Electronic/Online) ✓
6. **Drug Free Workplace Form** (Electronic/Online) ✓
7. **Current Certificate of Insurance** (Electronic/Online) ✓
8. **License/Certification to do Described Work** (Electronic/Online) ✓
9. **Reference Check Form** (Electronic/Online) ✓
10. **E-Bid Reply Excel Spreadsheet** (Electronic/Online) ✓
11. **E-Bid Bond** (Electronic/Online) ✓
12. **Vendor Code of Ethics** (Electronic/Online) ✓
13. **W-9 form** (Electronic/Online) ✓

Uploaded Documents

EDIT

1. test document upload to ensure e-bidding active

E-Bid Confirmation

After clicking "Submit Response" the following process will begin:

- We will verify that your response is complete as entered.
- You will see a confirmation page with your confirmation number and date/time stamp of your upload.
- You will receive a confirmation e-mail indicating a successful response submittal.
- You may track your response submission under the View Responses page.

If you do not receive any of the above, please call Supplier Services at (206) 940-0305.

<< Return

Submit Response

Confirmation of Response

- When you complete you will receive a confirmation
- This is a confirmation that what you uploaded will be visible to the agency when the bid closes, **this is not** a confirmation that all your documents were fill out or submitted correctly

E-Bid Response Details

Agency Name City of Port St. Lucie, Procurement Management Department

Bid Number EBID-20180218-0-2018/er

Bid Name **Sculpture on Lawn at City Hall Temporary Art Installation**

Bid Due Date 1/9/2019 2:00:00 PM Eastern time

Bid Opening 100 days, 1 hour, 6 minutes, 46 seconds

Response # 15104

Results Your bid response is submitted.

<< Return

Post Submission Edits

If you feel like you missed something or need to make a change you can go back to your submittal response and edit your e-bid. By clicking on “DETAILS” then “EDIT” the section you wish

Bid Identifier	Agency Name	Bid Status	Broadcast	Date Due ▼	Name	Status	Actions
EBID-20190077-0-2019/HF	City of Port St. Lucie, Procurement Management Department	Active	4/25/2019	5/31/2019	Purchase Breaching “Backpack” Kits, Gas Masks and Gas Mask Cartridges for the Police Department JAG Grant Funded	Incomplete	Details, Bid, History

Contact Information

EDIT

Company Name Sample DBE Company
Address 1 509 Olive Way
Address 2
City Seattle
State Washington
Postal Code 98101
Phone 2063739233
Fax 2063739233
Country United States of America
Bid Amount \$0.00
Alternate Bid Amount
Notes



Agency Required Documents

EDIT

1. Bid Reply (Electronic/Online) ✓



DemandStar E-Bidding: Frequently Asked Questions

- Do suppliers need to be registered with DemandStar to participate in e-bidding?
Yes. But if they don't already have an account with DemandStar, they can sign up and either
 - Be a subscriber for only your agency, at no charge, and be able to download documents at no charge and then receive notifications that match their commodity codes
 - Be a "basic supplier" for free - who researches on our platform and then pays \$5 to download all documents, thus becoming a plan holder
 - Be a paid subscriber for a county, state, national and receive notifications from all included agencies
- Can suppliers respond with document uploads or do they simply fill in forms?
Yes, they may respond with document uploads that are available to you via the DemandStar platform.
- What type of E-Bidding Documents can be uploaded?
Acceptable file formats for sending back documents that the city will accept:

E-Bidding Documents

Document Types	Bidding Documents - Exhibits Pricing Bid Bond
File Formats	Adobe Acrobat (*.PDF) Microsoft Excel (*.XLS) Microsoft Excel (*.XLSX) Microsoft PowerPoint (*.PPTX) Microsoft PowerPoint (*.PPT) ZIP Compressed Archive (*.ZIP)

- Is there a maximum file size that I can upload?
Vendors can simply upload a single file or multiple documents as long as it doesn't exceed 100 MBs (single or multiple files)
- After a bid opening, what document(s) are made public by DemandStar?
None. Only the agency can see the vendor responses so you are the only ones who will determine what you want to download and make public.
- Who do I call if I have questions or problems with the DemandStar?
The City strongly encourages each respondent to setup their account and to explore the eBidding module at least a couple of days before the bid due date.

If you have questions or issues creating your account, accessing the eBidding module or submitting your bid prior to the bid due date, please contact DemandStar at 866.273.1863 or by email at hello@demandstar.com.
