

## CONTRACTOR SERVICES AGREEMENT

The parties referenced herein desire to enter into an agreement for professional services for:

**Construction of the New Robert Crown Community Center, Ice Rink and Library  
(RFP #17-57)**

THIS AGREEMENT (hereinafter referred to as the "Agreement") is entered into between the City of Evanston, an Illinois municipal corporation with offices located at 2100 Ridge Avenue, Evanston Illinois 60201 (hereinafter referred to as the "City"), and Bulley and Andrews with offices located at 1755 West Armitage Avenue, Chicago, Illinois (hereinafter referred to as the "Contractor"). Compensation (the "Compensation") for all basic services provided by the Contractor pursuant to the terms of this Agreement shall not exceed \$41,510.00 for preconstruction services. Cost for construction services shall be determined upon the City's acceptance of the Construction Manager's Guaranteed Maximum Price proposal and the execution of the Guaranteed Maximum Price Amendment.

*Revision June 2013*

## TABLE OF CONTENTS

<u>1</u>	<u>Services and Duties of the Contractor</u> .....	3
<u>2</u>	<u>Standard Certifications</u> .....	7
<u>3</u>	<u>Additional Services/Change Orders</u> .....	10
<u>4</u>	<u>Bonds</u> .....	12
<u>5</u>	<u>Liquidated Damages in the Event Contractor Fails to Complete the Work</u> .....	13
<u>6</u>	<u>The City's Responsibilities</u> .....	14
<u>7</u>	<u>Period of Service</u> .....	14
<u>8</u>	<u>Payment for Services and Reimbursements</u> .....	14
<u>9</u>	<u>Notice and Cure/Termination</u> .....	15
<u>10</u>	<u>Insurance</u> .....	17
<u>11</u>	<u>Indemnification</u> .....	18
<u>12</u>	<u>Drawings and Documents</u> .....	19
<u>13</u>	<u>Successors and Assigns</u> .....	19
<u>14</u>	<u>Force Majeure</u> .....	19
<u>15</u>	<u>Amendments and Modifications</u> .....	20
<u>16</u>	<u>Standard of Care &amp; Warranty</u> .....	20
<u>17</u>	<u>Savings Clause</u> .....	22
<u>18</u>	<u>Non-Waiver of Rights</u> .....	22
<u>19</u>	<u>Entire Agreement</u> .....	22
<u>20</u>	<u>Governing Law</u> .....	22
<u>21</u>	<u>Ownership of Contract Documents</u> .....	22
<u>22</u>	<u>Notice</u> .....	23
<u>23</u>	<u>Severability</u> .....	23
<u>24</u>	<u>Execution of Agreement</u> .....	23
<u>25</u>	<u>Counterparts</u> .....	23
<u>26</u>	<u>Authorizations</u> .....	23
<u>27</u>	<u>Time of Essence</u> .....	24

## RECITALS

WHEREAS, the City intends to retain the services of a qualified and experienced contractor for the following:

Pre-construction and construction services for the new Robert Crown Community Center, Ice Complex and Library.

WHEREAS, this Agreement shall include the following documents which are attached hereto:

- a) City of Evanston RFP 17-57 attached as Exhibit A.
- b) Contractor's response to RFP 17-57 attached as Exhibit B.
- c) AIA A133-2009
- d) AIA A201-2007
- e) Any subcontractor subcontracts related to this Agreement, attached as Exhibit C.
- f) Project Fee Schedule and hourly rates, attached as Exhibit D (*if appropriate*).

Any conflicts between this Agreement and the attachments, the attachment language shall prevail.

NOW, THEREFORE, in consideration of the mutual covenants hereinafter set forth, the parties agree as follows:

### 1 Services and Duties of the Contractor

1.1 The Contractor shall perform professional services and provide equipment (the "Work") in accordance with Exhibits A – F. The Contractor retains the right to control the manner of performance of the services provided for in this Agreement and is an independent contractor and not agent or an employee of the City. All employees and subcontractors of the Contractor shall likewise not be considered to be employees of the City. Contractor is solely responsible for the means and methods of all work performed under the terms of this Agreement for this Project ("the Project"). Contractor is an independent Contractor and is solely responsible for all taxes, withholdings, and other statutory or contractual obligations of any sort, including but not limited to, Worker's Compensation Insurance. Nothing in this Agreement accords any third-party beneficiary rights whatsoever to any non-party to this Agreement that any non-party may seek to enforce. Contractor acknowledges and agrees that should Contractor or its subcontractors provide false information, or fail to be or remain in compliance with this Agreement, the City may void this Agreement.

1.2 The Contractor warrants and states that it has read the Contract Documents, and agrees to be bound thereby, including all performance guarantees as respects Contractor's work and all indemnity and insurance requirements. Contractor further affirms that it has visited the Project site and has become familiar with all special conditions, if any, at the Project site. Contractor shall perform the Work and its obligations under this Agreement in accordance with

and subject to the Contract Documents to the full extent that each such provision is applicable to the Work. Contractor shall take necessary precautions to properly protect the Work of others, if any, from damage caused by operations under this Agreement. In addition, Contractor shall protect the work during normal and adverse weather conditions until the Project is complete and accepted by the City, or until the Contractor has fully completed its work under this Agreement. Contractor's obligations include, but are not limited to, placing and adequately maintaining at or about all locations of Project work, sufficient guards, barricades, lights, and enclosures to protect the Work.

1.3 The Contractor shall not have any public or private interest and shall not acquire directly or indirectly any such interest which conflicts in any manner with the performance of its services under this Agreement.

1.4 The Contractor shall designate, in writing, a person to act as its Project Manager for the work to be performed under this Agreement. Such person shall have complete authority to transmit instructions, receive information, interpret and define the Contractor's policies and decisions with respect to the work covered by this Agreement.

1.5 The Contractor shall employ only persons duly licensed by the State of Illinois to perform the professional services required under this Agreement for which applicable Illinois law requires a license, subject to prior approval of the City. The Contractor shall employ only well qualified persons to perform any of the remaining services required under this Agreement, also subject to prior approval of the City. The City reserves the right to require replacement of Contractor, subcontractor, or supplier personnel for any reason. Contractor will replace the unacceptable personnel at no charge to the City. For all solicitations or advertisements placed by or on behalf of Contractor for employees for this Project it will state that the Contractor is an Equal Opportunity Employer.

1.6 Pursuant to the Illinois Freedom of Information Act, 5 ILCS 140/7(2), records in the possession of others whom the City has contracted with to perform a governmental function are covered by the Act and subject to disclosure within limited statutory timeframes (five (5) working days with a possible five (5) working day extension). Upon notification from the City that it has received a Freedom of Information Act request that calls for records within the Contractor's control, the Contractor shall promptly provide all requested records to the City so that the City may comply with the request within the required timeframe. The City and the Contractor shall cooperate to determine what records are subject to such a request and whether or not any exemptions to the disclosure of such records, or part thereof, is applicable. Contractor shall indemnify and defend the City from and against all claims arising from the City's exceptions to disclosing certain records which Contractor may designate as proprietary or confidential. Compliance by the City with an opinion or a directive from the Illinois Public Access Counselor or the Attorney General under FOIA, or with a decision or order of Court with jurisdiction over the City, shall not be a violation of this Section.

1.7 The Contractor shall obtain prior approval from the City prior to subcontracting with any entity or person to perform any of the work required under this Agreement. The Contractor may, upon request of the City, submit to the City a draft subcontractor agreement for

City review and approval prior to the execution of such an agreement. Any previously entered into subcontractor agreement(s) are attached as Exhibit C. If the Contractor subcontracts any of the services to be performed under this Agreement, the subcontractor agreement shall provide that the services to be performed under any such agreement shall not be sublet, sold, transferred, assigned or otherwise disposed of to another entity or person without the City's prior written consent. The Contractor shall be responsible for the accuracy and quality of any subcontractor's work.

1.8 The Contractor shall cooperate fully with the City, other City contractors, other municipalities and local government officials, public utility companies, and others, as may be directed by the City. This shall include attendance at meetings, discussions and hearings as requested by the City. This cooperation shall extend to any investigation, hearings or meetings convened or instituted by OSHA relative to this Project, as necessary. Contractor shall cooperate with the City in scheduling and performing its Work to avoid conflict, delay in or interference with the work of others, if any, at the Project.

1.9 The Contractor acknowledges that it shall enforce and comply with all applicable Occupational Safety and Health Administration standards (OSHA) for this Project in effect as of the date of the execution of this Agreement, or as otherwise promulgated by OSHA in the future taking effect during the pendency of this Project. Contractor shall enforce all such standards and ensure compliance thereto as to its own agents and employees, and as to the agents and employees of any subcontractor throughout the course of this Project. Contractor is solely responsible for enforcing and complying with all applicable safety standards and requirements on this Project, and is solely responsible for correcting any practices or procedures which do not comply with the applicable safety standards and requirements for this Project. Any Project specific safety requirements applicable to this Project must be followed by Contractor and any subcontractor(s) on the Project. Additionally, all such safety requirements shall be made a part of any subcontractor agreement.

1.10 The Contractor shall submit to the City a progress report each month this Agreement is in effect. The report shall include the following items:

- a) A summary of the Contractor's project activities, and any subcontractor project activities that have taken place during the invoice period;
- b) A summary of the Contractor's project activities and any subcontractor project activities, that shall take place during the next invoice period;
- c) A list of outstanding items due to or from the City; and
- d) A status of the Project schedule.

1.11 The Contractor shall perform the work required under this Agreement pursuant to high quality industry standards expected by the City. The Contractor shall apply for and receive all appropriate permits before performing any work in the City. The Contractor shall also provide the appropriate permit drawings for Building Permits to be issued for the Project, if said permits are obligated by the Project. The City will assist the Contractor with obtaining the appropriate building and right-of-way permits.

1.12 The Contractor shall provide drawings of record, in the following electronic formats for all locations where equipment has been installed and/or work has been performed. The electronic formats required by this Section 1.12 are AutoCad Version 2014, ArcView, Revit and PDF.

1.13 Contractor recognizes that proper cleanup and removal of construction debris is an important safety consideration. The Contractor shall be solely responsible for daily construction site/area cleanup and removal of all construction debris in accordance with City-approved disposal practices. Contractor shall be solely responsible for identifying and removing at its expense all hazardous material and waste which it uses and generates.

1.14 To the extent that there is any conflict between a provision specified in this Agreement, with a provision specified in any of the other Contract Documents, as defined in Section 1.15, this Agreement shall control. The City and the Contractor may amend this Section 1.14 as provided by Section 15 herein.

The Contractor acknowledges and agrees that the City has no retained control over any of the Work done pursuant to this Agreement, and that the City is expressly exempt from the retained control exception as defined in the Restatement of Torts, Second, Section 414. This provision shall survive completion, expiration, or termination of this Agreement.

1.15 The Contract Documents for this Project consist of:

- a) This Agreement;
- b) The City's RFP/RFQ, and the plans, specifications, general conditions, drawings addenda, and modifications thereto;
- c) The Contractor's response to the RFP/RFQ/Bid;
- d) Other exhibits and schedules, if any, listed in this Agreement;
- e) Amendments or Other Contract Documents, if any; and
- f) Amendments/Modifications to this Agreement issued after execution thereof.

1.16 As a condition of receiving payment, Contractor must (i) be in compliance with the Agreement, (ii) pay its employees prevailing wages when required by law (Examples of prevailing wage categories include public works, printing, janitorial, window washing, building and grounds services, site technician services, natural resource services, security guard and food services). Contractor is responsible for contacting the Illinois Dept. of Labor 217-782-6206; <http://www.illinois.gov/idol/Laws-Rules/CONMED/Pages/Rates.aspx> to ensure compliance with prevailing wage requirements), (iii) pay its suppliers and subcontractors according to the terms of their respective contracts, and (iv) provide lien waivers to the City upon request. All contractors and subcontractors on public works projects must submit certified payrolls on a monthly basis, in an electronic format (preferably PDF), to the City's project manager and business work force development coordinator, along with a statement affirming that such records are true and accurate, that the wages paid to each worker are not less than the required prevailing rate and that the contractor is aware that filing records her or she knows to be false is a Class B misdemeanor.

The certified payroll record must include for every worker employed on the public works project the name, address, telephone number, social security number, job classification, hourly

wages paid in each pay period, number of hours worked each day, and starting and ending time of work each day. These certified payroll records are considered public records and public bodies must make these records available to the public under the Freedom of Information Act, with the exception of the employee's address, telephone number and social security number. Any contractor who fails to submit a certified payroll or knowingly files a false certified payroll is guilty of a Class B misdemeanor.

## 2 Standard Certifications

Contractor acknowledges and agrees that compliance with this section and each subsection for the term of the Agreement is a material requirement and condition of this Agreement. By executing this Agreement, Contractor certifies compliance with this section and each subsection and is under a continuing obligation to remain in compliance and report any non-compliance.

This section, and each subsection, applies to subcontractors used on this Agreement. Contractor shall include these Standard Certifications in any subcontract used in the performance of the Agreement.

If this Agreement extends over multiple fiscal years, Contractor and its subcontractors shall confirm compliance with this section in the manner and format determined by the City by the date specified by the City and in no event later than January 1 of each year that this Agreement remains in effect.

If the City determines that any certification in this section is not applicable to this Agreement, it may be stricken, subject to sole approval by the City, without affecting the remaining subsections.

2.1 As part of each certification, Contractor acknowledges and agrees that should Contractor or its subcontractors provide false information, or fail to be or remain in compliance with the Standard Certification requirements, one or more of the following sanctions will apply:

- the Agreement may be void by operation of law,
- the City may void the Agreement, and
- Contractor and its subcontractors may be subject to one or more of the following: suspension, debarment, denial of payment, civil fine, or criminal penalty.

2.2 By signing this Agreement, the Contractor certifies that it has not been barred from being awarded a contract with a unit of State or local Government as a result of bid rigging or bid rotating or similar offense, nor has it made any admission of guilt of such conduct that is a matter of public record. (720 ILCS 5/33 E-3, E-4).

2.3 In the event of the Contractor's noncompliance with any provision of Section 1-12-5 of the Evanston City Code, the Illinois Human Rights Act or any other applicable law, the Consultant may be declared nonresponsible and therefore ineligible for future contracts or subcontracts with the City, and the contract may be cancelled or voided in whole or in part, and

such other sanctions or penalties may be imposed or remedies invoked as provided by statute or regulation.

2.4 During the term of this Agreement, the Contractor agrees as follows:

a) That it will not discriminate against any employee or applicant for employment because of race, color, religion, sex, sexual orientation, marital status, national origin or ancestry, or age or physical or mental disabilities that do not impair ability to work, and further that it will examine all job classifications to determine if minority persons or women are underutilized and will take appropriate affirmative action to rectify any such underutilization. Consultant shall comply with all requirements of City of Evanston Code Section 1-12-5. Affirmative Action in Contracting: "Contractor agrees that he shall actively solicit bids for the subcontracting of goods or services from qualified minority businesses. At the request of the City, Contractor shall furnish evidence of his compliance with this requirement of minority solicitation. Contractor further agrees to consider the grant of subcontracts to said minority bidders on the basis of substantially equal bids in the light most favorable to said minority businesses. Contractor further affirms that in obtaining his performance and bid bonds, he will seek out and use companies who have records of, and/or who will make commitments to, the bonding of minority contractors on a rate basis comparable to their bonding of similar non-minority contractors. The contractor may be required to submit this evidence as part of the bid or subsequent to it."

b) That, in all solicitations or advertisements for employees placed by it on its behalf, it will state that all applicants will be afforded equal opportunity without discrimination because of race, color, religion, sex, sexual orientation, marital status, national origin, ancestry, or disability.

2.5 The Contractor certifies pursuant to the Illinois Human Rights Act (775 ILCS 5/2-105 *et. seq.*), that it has a written sexual harassment policy that includes, at a minimum, the following information:

- a) The illegality of sexual harassment;
- b) The definition of sexual harassment under State law;
- c) A description of sexual harassment utilizing examples;
- d) The Contractor's internal complaint process including penalties;
- e) Legal recourse, investigation and complaint process available through the Illinois Department of Human Rights and the Human Rights Commission, and directions on how to contact both; and
- f) Protection against retaliation as provided to the Department of Human Rights.

2.6 In accordance with the Steel Products Procurement Act (30 ILCS 565), Contractor certifies steel products used or supplied in the performance of a contract for public works shall be manufactured or produced in the U.S. unless the City grants an exemption.

2.7 Contractor certifies that it is properly formed and existing legal entity and as



applicable has obtained an assumed name certificate from the appropriate authority, or has registered to conduct business in Illinois and is in good standing with the Illinois Secretary of State.

2.8 If Contractor, or any officer, director, partner, or other managerial agent of Contractor, has been convicted of a felony under the Sarbanes-Oxley Act of 2002, or a Class 3 or Class 2 felony under the Illinois Securities Law of 1953, Contractor certifies at least five years have passed since the date of the conviction.

2.9 Contractor certifies that if more favorable terms are granted by Contractor to any similar governmental entity in any state in a contemporaneous agreement let under the same or similar financial terms and circumstances for comparable supplies or services, the more favorable terms will be applicable under this Agreement.

2.10 Contractor certifies that it is not delinquent in the payment of any fees, fines, damages, or debts to the City of Evanston.

2.11 The Contractor certifies that all Design Professionals performing the Work under this Agreement will ensure that the Project shall be designed in conformance with the Americans with Disabilities Act of 1990, 42 U.S.C. Section 12101, *et seq.*, and all regulations promulgated thereunder. Design Professional means any individual, sole proprietorship, firm, partnership, joint venture, corporation, professional corporation, or other entity that offers services under the Illinois Architecture Practice Act of 1989 (225 ILCS 305/), the Professional Engineering Practice Act of 1989 (225 ILCS 325/), the Structural Engineering Licensing Act of 1989 (225 ILCS 340/), or the Illinois Professional Land Surveyor Act of 1989 (225 ILCS 330/).

2.12 The Contractor shall comply with all federal, state and local laws, statutes, ordinances, rules, regulations, orders or other legal requirements now in force or which may be in force during the term of this Agreement. The Contractor shall comply with the Illinois Human Rights Act, 775 ILCS 5/1-101 *et. seq.*, Title VII of the Civil Rights Act of 1964, and the Illinois Prevailing Wage Act, 820 ILCS 130/0.01 *et. seq.*

2.13 M/W/EBE Goal. The City of Evanston has a goal of awarding 25% of its contracts to Minority-Owned, Women-Owned, and Evanston-based businesses (M/W/EBEs). All Bidders must state the proposed involvement of M/W/EBEs in completing a portion of the services required by the City by completing the attached M/W/EBE forms. Any questions regarding M/W/EBE compliance should be submitted in writing to Sharon A. Johnson, Business Workforce Compliance Coordinator at [shjohnson@cityofevanston.org](mailto:shjohnson@cityofevanston.org) or Tammi Nunez Purchasing Manager at [tnunez@cityofevanston.org](mailto:tnunez@cityofevanston.org).

2.14 Local Employment Program Requirements. In an effort to increase hiring of economically disadvantaged Evanston residents on certain City construction projects, the contractor shall comply with the provisions of the City of Evanston's Local Employment Program Ordinance (LEP) set forth in Section 1-17-1 (C) of the Evanston City Code. The intent of the LEP is to have Evanston residents employed at the construction site as laborers, apprentices and journeymen in such trades as electrical, HVAC, carpenters, masonry, concrete

finishers, truck drivers and other construction occupations necessary for the project. Any questions regarding LEP compliance should be submitted in writing to Sharon A. Johnson, Business Workforce Compliance Coordinator at [shjohnson@cityofevanston.org](mailto:shjohnson@cityofevanston.org) or Tammi Nunez Purchasing Manager at [tnunez@cityofevanston.org](mailto:tnunez@cityofevanston.org).

2.15 Preference to Citizens. The Contractor shall abide by the Illinois Preference Act, 30 ILCS 570 et seq., which stipulates that whenever there is a period of excessive unemployment in Illinois, defined as any month immediately following two (2) consecutive months during which the level of unemployment in Illinois exceeds five percent (5%) as measured by the U.S. Bureau of Labor Statistics in its monthly publication of employment and unemployment figures, the Contractor shall employ only Illinois laborers unless otherwise exempted as so stated in the Act. ("Illinois laborer" means any person who has resided in Illinois for at least 30 days and intends to become or remain an Illinois resident) Other laborers may be used IF Illinois laborers are not available or are incapable of performing the particular type of work involved if so certified by the Contractor and approved by the project engineer.

### 3 Additional Services/Change Orders

3.1 If the representative of the City responsible for the Project verbally requests the Contractor to perform additional services, the Contractor shall confirm in writing that the services have been requested and that such services are additional services. Failure of the City to respond to the Contractor's confirmation of said services within thirty (30) calendar days of receipt of the notice shall be deemed a rejection of, and refusal to pay for the additional services. Contractor shall not perform any additional services until City has confirmed approval of said additional services in writing. If authorized in writing by the City, the Contractor shall furnish, or obtain from others, additional services of the following types, which shall be paid for by the City as set forth in Section 9 of this Agreement:

- a) Additional Services due to significant changes in scope of the Project or its design, including, but not limited to, changes in size, complexity or character of construction, or time delays for completion of work when such delays are beyond the control of the Contractor;
- b) Revisions of previously approved studies, reports, design documents, drawings or specifications;
- c) Preparation of detailed renderings, exhibits or scale models for the Project;
- d) Investigations involving detailed consideration of operations, maintenance and overhead expenses for the preparation of rate schedules, earnings and expense statements, feasibility studies, appraisals and valuations, detailed quantity surveys of material and labor, and material audits or inventories required for certification of force account construction performed by the City;
- e) Services not otherwise provided for in this Agreement.

3.2 The City may, upon written notice, and without invalidating this Agreement, require changes resulting in the revision or abandonment of work already performed by the Contractor, or require other elements of the work not originally contemplated and for which full compensation is not provided in any portion of this Agreement. Any additional services, abandonment of services which were authorized by the City, or changes in services directed by

the City which result in the revision of the scope of services provided for in Exhibits A, B, C, and D that cause the total Compensation due Contractor under this Agreement to exceed \$20,000 or more, or increase or decrease the contract duration by more than 30 days are subject to approval by the Evanston City Council. These actions must be addressed either in a written Change Order or in a written amendment to this Agreement approved by both parties.

3.3 Contractor acknowledges and agrees that the Public Works Construction Change Order Act, 50 ILCS 525/1 et seq. shall apply to all Change Orders for the Project. It is expressly understood and agreed to by Contractor that it shall not be entitled to any damages or Compensation from the City on account of delay or suspension of all or any part of the Work. Contractor acknowledges that delays are inherent in construction projects and Contractor assessed that risk and fully included that risk assessment within its contract sum specified in its Response to the City RFP 17-57 for this Project. The City shall not compensate Contractor for work that is more difficult than the contract sum specified in its Response would reflect. Delays to minor portions of the Work will not be eligible for extensions of time.

Delays to the Project caused by labor disputes or strikes involving trades not directly related to the Project, or involving trades not affecting the Project as a whole will not be eligible for an extension of time.

The City will not grant an extension of time for a delay by the Contractor's inability to obtain materials unless the Contractor first furnishes to the City documentary proof. The proof must be provided in a timely manner in accordance with the sequence of the Contractor's operations and accepted construction schedule.

In addition to any other changes requested by City (as described in Sections 3.1 and 3.2), the Company shall be entitled to request (and the City may grant) Change Orders with respect to:

- (a) The City-caused delays;
- (b) Change in Law;
- (c) Force Majeure Events.

The foregoing events shall entitle the Contractor to a change in the Compensation for this Project, if the Contractor demonstrates that it will unavoidably incur reasonable costs as a result thereof and the Contractor provides reasonable and detailed documentary support with respect to any such price impact.

The parties agree to reasonably confer regarding any such disputes with respect to the issuance of a Change Order.

Any payment for compensable delay will only be based upon actual costs excluding, without limitation, what damages, if any, the Contractor may have reasonably avoided. The Contractor understands that this is the sole basis for recovering delay damages and explicitly waives any right to calculate daily damages for office overhead, profit, or other purported loss.

All Contractor Change Orders authorized under this Section 3 shall be made in writing. In remitting a Change Order, the Contractor must first show in writing that:

- (a) The work was outside the scope of this Agreement,
- (b) The extra work was not made necessary due to any fault of Contractor;
- (c) The circumstances said to necessitate the change in performance were not reasonably foreseeable at the time the Agreement was signed;
- (d) The change is germane to the original Agreement; and
- (e) The Change Order is in the best interest of the City and authorized by law.

Any person who fails to first obtain the City's written authorization for a Change Order commits a Class 4 felony. The written determination and the written Change Order resulting from that determination shall be preserved in the contract's file which shall be open to the public for inspection.

**The City reserves all rights and causes of action, at law or equity, to seek redress against entities or persons who violate the requirements of this Section 3. By initialing below, Contractor hereby acknowledges that it is bound by this Section 3.**

Contractor's Initials: MP

3.4 The Contractor is required to include the City of Evanston as a reference whenever and wherever the Contractor provides references for similar projects for a period of one (1) year from the date of Final Acceptance by the City of the Work for this Project.

#### 4 Bonds

4.1 Before the Scheduled Construction Commencement Date, the Contractor is required to furnish unconditional performance and payment bonds in the amount of 110% of the Compensation as security for the faithful performance and completion of all the Contractor's obligations under the Contract Documents and covering the payment of all materials used in the performance of this Agreement and for all labor and services performed under this Agreement. All Bonds shall be issued on a form acceptable to the City. The bonds must be for the entire term of the Agreement. Failure to provide these bonds shall constitute a breach of Contractor's obligations under this Agreement. Each surety providing the Bonds must have a Best's rating not less than A/X and be licensed in Illinois and shall be named in the current list of "Companies Holding Certificates of Authority as Acceptable Sureties on Federal Bonds and as Acceptable Reinsuring Companies" as published in Circular 570 as published in the Federal Register and available on the website of the U.S. Department of the Treasury, Financial Management Service, at [www.fms.treas.gov/c570/c570.html](http://www.fms.treas.gov/c570/c570.html). All Bonds signed by an agent must be accompanied by a certified copy of his or her authority to act. It shall be the duty of the Contractor to advise the surety or sureties of any Change Orders that result in an increase to the Compensation and to ensure that the amounts of the Bonds are updated to reflect and cover any such increases throughout the course of the Project. The cost of such Bonds shall be included within the Compensation.

4.2 If the surety behind any Bond furnished by the Contractor is declared bankrupt or

becomes insolvent or its right to do business is terminated in the State or it ceases to meet any of the requirements of this Contract, the Contractor shall, within [5] five days thereafter, substitute another Bond of equivalent value and surety, both of which must be acceptable to the City. In addition, no further progress payments under the Agreement will be made by the City until the Contractor complies with the provisions of this Agreement. The Contractor shall furnish to the City proof of any required bonds and proof of required insurance as one of the conditions precedent to payment under the Agreement. Upon the request of any person or entity appearing to be a potential beneficiary of bonds covering payment or performance of obligations arising under the Contract, the Contractor shall promptly furnish a copy of the bonds or authorize a copy to be furnished. All surety Bonds provided for in this Section shall incorporate by reference this Agreement, and any language that may be in any such surety Bond which conflicts with the provisions of this Agreement that define the scope of the surety('s) duty(ies) shall be of no force and effect.

## 5 Liquidated Damages in the Event Contractor Fails to Complete the Work

5.1 The parties agree that failure of Contractor to timely complete the Work required by this Agreement constitutes a default. The parties agree that this default will result in damage and injury to City. The parties further agree, however, that actual damages incurred by City as result of such default is difficult if not impossible to ascertain with any degree of certainty or accuracy. Accordingly, the parties have negotiated and have agreed that for each calendar day after written notice is delivered to Contractor and Contractor fails to cure such default, that Contractor will pay City, as and for liquidated damages, and not as a penalty. The Contractor must commence work within 10 days of notice to proceed from the City and the work must be substantially completed by date(s) to be determined and incorporated into the Guaranteed Maximum Price Amendment. In the event the work is not substantially completed by the date(s) incorporated into the Guaranteed Maximum Price Amendment, then in addition to any remedies available to the City, the Contractor will pay to the City the sum of the per day amount listed below for each calendar day beyond those dates, until substantial completion of the work has been achieved for the applicable portion of the project. The liquidated damages schedule is as follows:

- Day 1 – 10: \$500 per calendar day;
- Day 11 – 30: \$1,000 per calendar day; and
- After 31 Days: \$1,500 per calendar day.

Contractor shall reimburse the City for all costs, expenses and fees (including, without limitation, attorneys' fees), if any, paid by the City in connection with such written demand by City. Contractor stipulates and agrees that the sums payable by Contractor under this Section are reasonable under the circumstances existing as of the execution of this Agreement. This Section 5.1 is not intended to limit any direct damages that may be recoverable by City related to the Contractor's failure to complete the Work in accordance with this Agreement. There shall be no early completion bonus if the Work is completed before the substantial completion date. The City, at its option, may withhold liquidated damages from progress payments payable to Contractor before the substantial completion date.

## 6 The City's Responsibilities

6.1 The City may evaluate the Contractor's and any subcontractor's performance (interim and final). Timeliness in meeting the Project schedule and the overall relationship with the Contractor are factors that will be considered in the Contractor's performance rating. An unfavorable performance rating may be a factor when future assignments are being considered.

6.2 The City makes no representation or warranty of any nature whatsoever as to the accuracy of information or documentation provided by the City to the Contractor which were generated or provided by third parties.

## 7 Period of Service

7.1 The Contractor shall commence work on the Project after supplying the City with the Contractor's performance and payment bonds and all required insurance documents before starting its Work on this Project. The City shall determine when the Contractor has completed the Work required pursuant to this Agreement, and shall determine the date of Final Acceptance. Contractor recognizes time is of the essence regarding its performance on this Project. Contractor shall continue to perform its obligations while any dispute concerning the Agreement is being resolved, unless otherwise directed by the City.

7.2 Each phase of the project shall be completed in accordance with the activities outlined in the City's RFP 17-57 Exhibit A. Project phases include:

- 7.2.1 Phase 1: preconstruction
- 7.2.2 Phase 2a: construction of new Robert Crown Center and partial construction of new parking lot
- 7.2.3 Phase 2b: demolition of old Robert Crown Center
- 7.2.4 Phase 2c: construction of new athletic fields and remainder of new parking lot

Refinement of the above phases may occur during development of the Guaranteed Maximum Price Amendment.

## 8 Payment for Services and Reimbursements

8.1 Within the first five (5) business days of each month, the Contractor shall invoice the City for Work completed during the previous month. The Contractor shall provide a detailed invoice that relates invoiced items to the Contractor's response to RFP 17-57 in both quantity and unit cost. Any discrepancies in the monthly invoice shall be promptly brought to the attention of the Contractor by the City Project Manager and efforts shall be made to promptly resolve said discrepancies between the City and Contractor. In the event the City and Contractor cannot resolve invoice discrepancies, items in dispute will be removed from the invoice and the City shall approve the remainder of the invoice. Payment will be made as soon as possible following the City Council meeting in which the item appeared on the bills list, and in accordance with all applicable laws and rules of the City of Evanston and the State of Illinois.

8.2 In the event of termination by the City of this Agreement pursuant to paragraph 9.1 after completion of any phase of the basic services, fees due the Contractor for services

rendered through such phase shall constitute final payment for such services, and no further fees shall be due to the Contractor. In the event of such termination by the City during any phase of the basic services, the Contractor shall be paid for services rendered on the basis of the proportion of work completed on the phase to date of termination.

8.3 The City shall have the right to withhold payment to the Contractor due to the quality of a portion or all of the work performed hereunder which is not in accordance with the requirements of this Agreement, or which is unsatisfactory, or is due to the Contractor's failure or refusal to perform any of its obligations hereunder. Compensation in excess of the total contract amount specified in this Agreement will not be allowed unless justified in the City's sole judgment and authorized in advance as provided for in Section 3 of this Agreement. Compensation for improper performance by the Contractor is disallowed.

8.4 Upon completion of the Work performed by the Contractor, prior to the submission of a request for final payment, the City and Contractor shall perform a final acceptance test and review of the Work performed and/or equipment installed pursuant to the Agreement. A punch list of items outstanding will be jointly developed by the City and Contractor. In addition, the Contractor shall submit drawings of record for the Project for the City to approve. The Contractor shall promptly resolve all punch list items to the satisfaction of the City, and shall transmit to the City in writing confirmation that all punch list items have been resolved. The City will review, and the Contractor shall modify, as necessary, any drawings of record to the satisfaction of the City. Punch list items and drawings of record must be approved by the City prior to the Contractor submitting its final invoice for payment.

8.5 The Contractor shall submit an Affidavit and a final waiver of its lien, and all final waivers of liens of any subcontractors, suppliers, and sub-subcontractors, if applicable, with its final invoice, stating that all obligations incurred in performance of the professional services have been paid in full. The Affidavit will also include a statement stating that the professional services were performed in compliance with the terms of the Agreement. The Affidavit and all final lien waivers shall be on a form acceptable to the City.

8.6 All Project invoices shall be sent to:

City of Evanston  
Public Works Agency  
2100 Ridge Avenue  
Evanston, Illinois 60201  
Attn: Stefanie Levine

## 9 Notice and Cure/Termination

9.1 In furtherance of Contractor's Work on this Project, the City and the Contractor agree that the following Notice and Cure provision in this Section 9.1 shall apply during the duration of Contractor's work on this Project, in addition to the reserved rights of the City enumerated in this Agreement as follows:

5.1 Liquidated Damages;

- 8.3 City's right to withhold payment;
- 16.2 Contractor's duty to revise and correct errors; and
- 16.3 Contractor's duty to respond to City's notice of errors and omissions.

The City may notify Contractor of its intent to terminate this Agreement within (7) seven calendar days of issuance by the City of written notice to Contractor's Project Manager regarding defects in the Project or in Contractor's Work. The City shall specify any such nonconforming Work or defects in the Project in its notice to Contractor under this Section 9.1. Contractor will have the opportunity to cure the non-conforming Work within (7) seven calendar days after receipt of the written notice issued by the City. All such curative work done shall be performed and completed to the City's satisfaction. Nothing in this Section 9.1 shall otherwise affect the City's right to exercise its rights in Section 9.2.

9.2 The City shall have the right to terminate this Agreement upon fifteen (15) days written notice for any reason. Mailing of such notice shall be equivalent to personal notice and shall be deemed to have been given at the time of receipt.

Payments made by the City pursuant to this Agreement are subject to sufficient appropriations made by the City of Evanston City Council. In the event of termination resulting from non-appropriation or insufficient appropriation by the City Council, the City's obligations hereunder shall cease and there shall be no penalty or further payment required.

9.3 Within thirty (30) days of termination of this Agreement, the Contractor shall turn over to the City any documents, drafts, and materials, including but not limited to, outstanding work product, data, studies, test results, source documents, AutoCad Version 2014, ArcView, Revit, PDF, Word, Excel spreadsheets, technical specifications and calculations, and any other such items specifically identified by the City related to the Work herein. Upon receipt of said items, the Contractor shall be paid for labor and expenses incurred to the date of termination as provided in Section 8.2. This Agreement is subject to termination by either party if either party is restrained by a state or federal court of competent jurisdiction from performing the provisions of this Agreement. Upon such termination, the liabilities of the parties to this Agreement shall cease, but they shall not be relieved of the duty to perform their obligations through the date of termination. No lien shall be filed by the Contractor in the event of a termination of this Agreement by the City.

9.4 If, because of death or any other occurrence, including, but not limited to, Contractor becoming insolvent, it becomes impossible for any principal or principals of the Contractor to render the services set forth in this Agreement, neither the Contractor, nor its surviving principals shall be relieved of their obligations to complete the professional services. However, in the event of such an occurrence, the City at its own option may terminate this Agreement if it is not furnished evidence that competent professional services can still be furnished as scheduled.

9.5 In the event of an emergency or threat to the life, safety or welfare of the citizens of the City, the City shall have the right to terminate this Agreement without prior written notice.



## 10 Insurance

10.1 The Contractor shall, at its own expense, secure and maintain in effect throughout the duration of this contract, insurance against claims for injuries to persons or damages to property which may arise from or in connection with the performance of the Work hereunder by the Contractor, its agents, representatives, employees or subcontractors. Contractor acknowledges and agrees that if it fails to comply with all requirements of this Section 10, the City may void the Agreement. Article 8 of AIA 133-2009 sets forth the limits required for Contractor.

The Contractor must give to the City Certificates of Insurance identifying the City to be an Additional Insured for all Work done pursuant to this Agreement before City staff recommends award of the contract to City Council. Any limitations or modifications on the Certificate(s) of Insurance issued to the City in compliance with this Section that conflict with the provisions of this Section 10 shall have no force and effect.

After award of the Contract to Contractor, the Contractor **shall** give the City a certified copy(ies) of the insurance policy(ies) evidencing the amounts set forth in Section 10.2, and copies of the Additional Insured endorsement to such policy(ies) which name the City as an Additional Insured for all Work done pursuant to this Agreement before Contractor does any Work pursuant to this Agreement. Contractor's certificate of insurance shall contain a provision that the coverage afforded under the policy(s) will not be canceled or reduced without thirty (30) days prior written notice (hand delivered or registered mail) to the City. Contractor shall promptly forward new certificate(s) of insurance evidencing the coverage(s) required herein upon annual renewal of the subject policies.

The policies and the Additional Insured endorsement must be delivered to the City within two (2) weeks of the request. All insurance policies shall be written with insurance companies licensed or authorized to do business in the State of Illinois and having a rating of not less than A rating according to the A.M. Best Company. Should any of the insurance policies be canceled before the expiration date, the issuing company will mail thirty (30) days written notice to the City. The Contractor shall require and verify that all subcontractors maintain insurance meeting all of the requirements stated herein.

Any deductibles or self-insured retentions must be declared to and approved by the City. At the option of the City, either the insurer shall reduce or eliminate such deductibles or self-insured retentions as respects the City, its officers, officials, employees and volunteers; or the Contractor shall provide a financial guarantee satisfactory to the City guaranteeing payment of losses and related investigations, claim administration and defense expenses.

10.2 Contractor shall carry and maintain at its own cost with such companies as are reasonably acceptable to City all necessary liability insurance (which shall include as a minimum the requirements set forth below) during the term of this Agreement, for damages caused or contributed to by Contractor, and insuring Contractor against claims which may arise out of or result from Contractor's performance or failure to perform the Services hereunder.

Contractor understands that the acceptance of Certificates of Insurance, policies, and any

other documents by the City in no way releases the Contractor and its subcontractors from the requirements set forth herein.

Contractor expressly agrees to waive its rights, benefits and entitlements under the "Other Insurance" clause of its commercial general liability insurance policy as respects the City. Contractor expressly agrees that its insurance coverage is required to be primary by this Agreement, that its insurance coverage shall be on a primary and non-contributory basis, and that it and its insurance carrier are estopped from denying such coverage is primary. In the event Contractor fails to purchase or procure insurance as required above, the parties expressly agree that Contractor shall be in default under this Agreement, and that the City may recover all losses, attorney's fees and costs expended in pursuing a remedy, or reimbursement, at law or in equity, against Contractor.

## 11 Indemnification

11.1 The Contractor shall defend, indemnify and hold harmless the City and its officers, elected and appointed officials, agents, and employees from any and all liability, losses, or damages as a result of claims, demands, suits, actions, or proceedings of any kind or nature, including but not limited to costs, and fees, including attorney's fees, judgments or settlements, resulting from or arising out of any negligent or willful act or omission on the part of the Contractor or Contractor's subcontractors, employees, agents or subcontractors during the performance of this Agreement. Such indemnification shall not be limited by reason of the enumeration of any insurance coverage herein provided. This provision shall survive completion, expiration, or termination of this Agreement.

11.2 Nothing contained herein shall be construed as prohibiting the City, or its officers, agents, or employees, from defending through the selection and use of their own agents, attorneys, and experts, any claims, actions or suits brought against them. The Contractor shall be liable for the costs, fees, and expenses incurred in the defense of any such claims, actions, or suits. Nothing herein shall be construed as a limitation or waiver of defenses available to the City and employees and agents, including but not limited to the Illinois Local Governmental and Governmental Employees Tort Immunity Act, 745 ILCS 10/1-101 *et seq.*

At the City Corporation Counsel's option, Contractor must defend all suits brought upon all such Losses and must pay all costs and expenses incidental to them, but the City has the right, at its option, to participate, at its own cost, in the defense of any suit, without relieving Contractor of any of its obligations under this Agreement. Any settlement of any claim or suit related to this Project by Contractor must be made only with the prior written consent of the City Corporation Counsel, if the settlement requires any action on the part of the City.

To the extent permissible by law, Contractor waives any limits to the amount of its obligations to indemnify, defend, or contribute to any sums due under any Losses, including any claim by any employee of Contractor that may be subject to the Illinois Workers Compensation Act, 820 ILCS 305/1 *et seq.* or any other related law or judicial decision, including but not limited to, *Kotecki v. Cyclops Welding Corporation*, 146 Ill. 2d 155 (1991). The City, however, does not waive any limitations it may have on its liability under the Illinois Workers Compensation Act, the Illinois Pension Code or any other statute.

11.3 The Contractor shall be responsible for any losses and costs to repair or remedy work performed under this Agreement resulting from or arising out of any act or omission, neglect, or misconduct in the performance of its Work or its subcontractors' work. Acceptance of the work by the City will not relieve the Contractor of the responsibility for subsequent correction of any such error, omissions and/or negligent acts or of its liability for loss or damage resulting therefrom.

11.4 All provisions of this Section 11 shall survive completion, expiration, or termination of this Agreement.

## 12 Drawings and Documents

12.1 Any drawings, survey data, reports, studies, specifications, estimates, maps, plans, computations, and other documents required to be prepared by the Contractor for the Project shall be considered Works for Hire and the sole property of the City.

12.2 The Contractor and its subcontractor shall maintain for a minimum of three (3) years after the completion of this Agreement, or for three (3) years after the termination of this Agreement, whichever comes later, adequate books, records and supporting documents to verify the amounts, recipients and uses of all disbursements of funds passing in conjunction with the Agreement. The Agreement and all books, records and supporting documents related to the Agreement shall be available for review and audit by the City and the federal funding entity, if applicable, and the Contractor agrees to cooperate fully with any audit conducted by the City and to provide full access to all materials. Failure to maintain the books, records and supporting documents required by this Subsection shall establish a presumption in favor of the City for recovery of any funds paid by the City under the Agreement for which adequate books, records, and supporting documentation are not available to support their purported disbursement.

## 13 Successors and Assigns

13.1 The City and the Contractor each bind themselves and their partners, successors, executors, administrators, and assigns to the other party of the Agreement and to the partners, successors, executors, administrators, and assigns of such other party in respect to all covenants of this Agreement. Neither the City nor the Contractor shall assign, sublet, or transfer its interest in this Agreement without the written consent of the other. Nothing herein shall be construed as creating any personal liability on the part of any officer or agent of any public body, which may be a party hereto, nor shall it be construed as giving any right or benefits hereunder to anyone other than the City and the Contractor.

## 14 Force Majeure

14.1 Whenever a period of time is provided for in this Agreement for the Contractor or the City to do or perform any act or obligation, neither party shall be liable for any delays or inability to perform if such delay is due to a cause beyond its control and without its fault or negligence including, without limitation:

- a) Acts of nature;

- b) Acts or failure to act on the part of any governmental authority other than the City or Contractor, including, but not limited to, enactment of laws, rules, regulations, codes or ordinances subsequent to the date of this Agreement;
- c) Acts or war;
- d) Acts of civil or military authority;
- e) Embargoes;
- f) Work stoppages, strikes, lockouts, or labor disputes;
- g) Public disorders, civil violence, or disobedience;
- h) Riots, blockades, sabotage, insurrection, or rebellion;
- i) Epidemics or pandemics;
- j) Terrorist acts;
- k) Fires or explosions;
- l) Nuclear accidents;
- m) Earthquakes, floods, hurricanes, tornadoes, or other similar calamities;
- n) Major environmental disturbances; or
- o) Vandalism.

If a delay is caused by any of the *force majeure* circumstances set forth above, the time period shall be extended for only the actual amount of time said party is so delayed. Further, either party claiming a delay due to an event of *force majeure* shall give the other party written notice of such event within three (3) business days of its occurrence or it shall be deemed to be waived.

## 15 Amendments and Modifications

15.1 Except as otherwise provided herein, the nature and scope of Work specified in this Agreement may only be modified by a written Change Order, or a written amendment to this Agreement, approved by both parties. This Agreement may be modified or amended from time to time provided, however, that no such amendment or modifications shall be effective unless reduced to writing and duly authorized and signed by the authorized representatives of the parties.

## 16 Standard of Care & Warranty

16.1 The Contractor shall perform all of the provisions of this Agreement to the satisfaction of the City. The City shall base its determination of the Contractor's fulfillment of the scope of the work in accordance with generally accepted professional standards applicable to the Work for this Project. The Contractor shall perform all of the provisions of this Agreement with that degree of care and skill ordinarily exercised by members of the same profession currently practicing under similar conditions.

16.2 The Contractor shall be responsible for the accuracy of its professional services under this Agreement and shall promptly make revisions or corrections resulting from its errors, omissions, or negligent acts without additional compensation. The City's acceptance of any of the Contractor's professional services shall not relieve the Contractor of its responsibility to subsequently correct any such errors or omissions. If a Contractor has provided the City with specifications for this Project which are determined to be incorrect or which require revision

during the solicitation process (including but not limited to Requests for Proposals, Requests for Qualifications, or bids), the Contractor shall make such corrections or revisions to the specifications at no cost to the City. Further, upon receipt of an invoice from the City, the Contractor shall promptly reimburse the City for the reasonable costs associated with the preparation and dissemination of said corrections or revisions to appropriate parties, including but not limited to preparation of the corrected or revised documents, and printing and distribution costs.

16.3 During the pendency of its Work on this Project, the Contractor shall respond to the City's notice of any errors or omissions within twenty-four (24) hours. The Contractor shall be required to promptly visit the Project site(s) if directed to by the City.

16.4 The Contractor shall comply with all federal, state, and local statutes, regulations, rules, ordinances, judicial decisions, and administrative rulings applicable to its performance under this Agreement.

16.5 Contractor guarantees and warrants to the City that:

- a) All materials and equipment furnished under this Agreement shall be of good quality and new, unless otherwise required or permitted by the Contract Documents;
- b) The Work of this Agreement shall be free from defects which are not inherent in the quality required; and
- c) The Work shall comply with the requirements set forth in the Contract Documents.

This warranty and guarantee shall be for a period of one (1) year from the date of completion and Final Acceptance of the Work by the City, or as otherwise provided in the Contract Documents. The contractor shall repair or replace any item or component part thereof found not to be in conformity with this paragraph provided the City notified the Seller of such nonconformity within one (1) year after initial use or within eighteen (18) months after delivery, whichever occurs first. In the event Seller fails to proceed diligently to so replace or repair within a reasonable time after receipt of such notice, the City may undertake or complete such replacement or repair for Seller's account, and the seller will be responsible for any additional costs. Acceptance shall not relieve the seller of its responsibility.

If, within the one year warranty period, after the Contractor has received a final payment under this Agreement, any of the Work is found to be not be in accordance with the requirements of this Agreement, or where defects in materials or workmanship may appear, or be in need of repair, the Contractor shall correct non-conforming and/or defective work or materials promptly after receipt of written notice from the City. Contractor shall immediately at its own expense repair, replace, restore, or rebuild any such Work. This remedy is in addition to any other legal or equitable remedies the City may have under this Agreement or the law.

This guarantee and warranty shall not relieve Contractor of liability for latent defects, and shall be in addition to the City's rights under the law or other guarantees or warranties, express

or implied.

16.6 The provisions of this Section 16 shall survive the completion, expiration or termination of this Agreement.

#### 17 Savings Clause

17.1 If any provision of this Agreement, or the application of such provision, shall be rendered or declared invalid by a court of competent jurisdiction, or by reason of its requiring any steps, actions, or results, the remaining parts or portions of this Agreement shall remain in full force and effect.

#### 18 Non-Waiver of Rights

18.1 No failure or delay by the City to exercise any power given to it hereunder or to insist upon strict compliance by Contractor with its obligations hereunder, nor any payment made by the City under this Agreement, shall constitute a waiver of the City's right to demand strict compliance with the terms hereof, unless such waiver is in writing and signed by the City.

#### 19 Entire Agreement

19.1 This Agreement sets forth all the covenants, conditions and promises between the parties with regard to the subject matter set forth herein. There are no covenants, promises, agreements, conditions or understandings between the parties, either oral or written, other than those contained in this Agreement. This Agreement has been negotiated and entered into by each party with the opportunity to consult with its counsel regarding the terms therein. No portion of the Agreement shall be construed against a party due to the fact that one party drafted that particular portion as the rule of *contra proferentem* shall not apply.

#### 20 Governing Law

20.1 This Agreement shall be construed in accordance with and subject to the laws and rules of the City of Evanston and the State of Illinois both as to interpretation and performance. Venue for any action arising out of or due to this Agreement shall be in Cook County, Illinois. The City shall not enter into binding arbitration to resolve any dispute related to this Agreement. The City does not waive tort immunity by entering into this Agreement.

#### 21 Ownership of Contract Documents

21.1 Contractor is specifically prohibited from using in any form or medium, the name or logo of the City for public advertisement, unless expressly granted written permission by the City. Submission or distribution of documents to meet official regulatory requirements or for similar purposes in connection with this Project is not to be construed as publication in derogation of the City's reserved rights.

## 22 Notice

22.1 Any notice required to be given by this Agreement shall be deemed sufficient if made in writing and sent by certified mail, return receipt requested, or by personal service, to the persons and addresses indicated below or to such other addresses as either party hereto shall notify the other party of in writing pursuant to the provisions of this Subsection:

City of Evanston Project Manager, RFP 17-57  
2100 Ridge Avenue  
Evanston, Illinois 60201

if to the Contractor:

Bulley & Andrews  
1755 W. Armitage Avenue  
Chicago, IL 60622

22.2 Mailing of such notice as and when provided above shall be equivalent to personal notice and shall be deemed to have been given at the time of mailing.

## 23 Severability

23.1 Except as otherwise provided herein, the invalidity or unenforceability of any particular provision, or part thereof, of this Agreement shall not affect the other provisions, and this Agreement shall continue in all respects as if such invalid or unenforceable provision had not been contained herein.

## 24 Execution of Agreement

24.1 This Agreement shall be signed last by the City Manager.

## 25 Counterparts

25.1 For convenience, this Agreement may be executed in any number of counterparts, each of which shall be deemed to be an original.

## 26 Authorizations

26.1 The Contractor's authorized representatives who have executed this Agreement warrant that they have been lawfully authorized by the Contractor's board of directors or its bylaws to execute this Agreement on its behalf. The City Manager affirms that he/she has been lawfully authorized to execute this Agreement. The Contractor and the City shall deliver upon request to each other copies of all articles of incorporation, bylaws, resolutions, ordinances, or other documents which evidence their legal authority to execute this Agreement on behalf of their respective parties.

## 27 Time of Essence

27.1 Time is of the essence with respect to each provision hereof in which time is a factor.



IN WITNESS WHEREOF, the parties hereto have caused this Agreement to be signed by their duly authorized representatives. The effective date of this Agreement will be the date this Agreement is signed by the City Manager.

**CONTRACTOR**

By: Tim Putillo

Name: Tim Putillo

Its: President

Date: 2/27/18

**CITY OF EVANSTON**

By: Wally Bobkiewicz  
Wally Bobkiewicz

Its: City Manager

Date: 3-8-18

Approved as to form:

By: W. Grant Farrar

W. Grant Farrar

Its: Corporation Counsel

Revision: June 2013

 **AIA® Document A133™ – 2009**

**Standard Form of Agreement Between Owner and Construction Manager as Constructor where the basis of payment is the Cost of the Work Plus a Fee with a Guaranteed Maximum Price**

**AGREEMENT** made as of the    day of    in the year  
*(In words, indicate day, month and year.)*

**BETWEEN** the Owner:  
*(Name, legal status and address)*

City of Evanston  
2100 Ridge Avenue  
Evanston, Illinois 60201

and the Construction Manager:  
*(Name, legal status and address)*

Bulley & Andrews  
1755 W. Armitage Avenue  
Chicago, Illinois 60622

for the following Project:  
*(Name and address or location)*

Robert Crown Community Center, Ice Complex, and Library  
1801 Main Street Evanston, Illinois 60202

The Architect:  
*(Name, legal status and address)*

Woodhouse Tinucci Architects  
230 W Superior Street 6FL  
Chicago, IL 60654

The Owner's Designated Representative:  
*(Name, address and other information)*

Erika Storlie  
City of Evanston  
2100 Ridge Avenue  
Evanston, Illinois 60201  
847-448-8007estorlie@cityofevanston.org  
The Construction Manager's Designated Representative:  
*(Name, address and other information)*

Tim Puntillo  
Bulley & Andrews  
1755 W. Armitage Avenue  
Chicago, Illinois 60622  
773-645-5813

**ADDITIONS AND DELETIONS:**  
The author of this document has added information needed for its completion. The author may also have revised the text of the original AIA standard form. An *Additions and Deletions Report* that notes added information as well as revisions to the standard form text is available from the author and should be reviewed. A vertical line in the left margin of this document indicates where the author has added necessary information and where the author has added to or deleted from the original AIA text.

This document has important legal consequences. Consultation with an attorney is encouraged with respect to its completion or modification.

AIA Document A201™-2007, General Conditions of the Contract for Construction, is adopted in this document by reference. Do not use with other general conditions unless this document is modified.

tpuntillo@bulley.com

The Architect's Designated Representative:  
*(Name, address and other information)*

David Woodhouse

Telephone Number: 312-943-3120

Fax Number: 312-943-3432

Mobile Number: 773-562-7278

Email Address: d.woodhouse@woodtinarch.com

The Owner and Construction Manager agree as follows.

int.

## TABLE OF ARTICLES

1	GENERAL PROVISIONS
2	CONSTRUCTION MANAGER'S RESPONSIBILITIES
3	OWNER'S RESPONSIBILITIES
4	COMPENSATION AND PAYMENTS FOR PRECONSTRUCTION PHASE SERVICES
5	COMPENSATION FOR CONSTRUCTION PHASE SERVICES
6	COST OF THE WORK FOR CONSTRUCTION PHASE
7	PAYMENTS FOR CONSTRUCTION PHASE SERVICES
8	INSURANCE AND BONDS
9	DISPUTE RESOLUTION
10	TERMINATION OR SUSPENSION
11	MISCELLANEOUS PROVISIONS
12	SCOPE OF THE AGREEMENT

## EXHIBIT A GUARANTEED MAXIMUM PRICE AMENDMENT

### ARTICLE 1 GENERAL PROVISIONS

#### § 1.1 The Contract Documents

The Contract Documents consist of this Agreement, Conditions of the Contract (General, Supplementary and other Conditions), Drawings, Specifications, Addenda issued prior to the execution of this Agreement, other documents listed in this Agreement, and Modifications issued after execution of this Agreement, all of which form the Contract and are as fully a part of the Contract as if attached to this Agreement or repeated herein. Upon the Owner's acceptance of the Construction Manager's Guaranteed Maximum Price proposal, the Contract Documents will also include the documents described in Section 2.2.3 and identified in the Guaranteed Maximum Price Amendment and revisions prepared by the Architect and furnished by the Owner as described in Section 2.2.8. The Contract represents the entire and integrated agreement between the parties hereto and supersedes prior negotiations, representations or agreements, either written or oral. If anything in the other Contract Documents, other than a Modification, is inconsistent with this Agreement, this Agreement shall govern.

#### § 1.2 Relationship of the Parties

The Construction Manager accepts the relationship of trust and confidence established by this Agreement and covenants with the Owner to cooperate with the Architect and exercise the Construction Manager's skill and judgment in furthering the interests of the Owner; to furnish efficient construction administration, management services and supervision; to furnish at all times an adequate supply of workers and materials; and to perform the Work in an expeditious and economical manner consistent with the Owner's interests. The Owner agrees to furnish or approve, in a timely manner, information required by the Construction Manager and to make payments to the Construction Manager in accordance with the requirements of the Contract Documents.

#### § 1.3 General Conditions

For the Preconstruction Phase, AIA Document A201™-2007, General Conditions of the Contract for Construction, shall apply only as specifically provided in this Agreement. For the Construction Phase, the general conditions of the contract shall be as set forth in A201-2007, which document is incorporated herein by reference. The term "Contractor" as used in A201-2007 shall mean the Construction Manager.

Init.

## ARTICLE 2 CONSTRUCTION MANAGER'S RESPONSIBILITIES

The Construction Manager's Preconstruction Phase responsibilities are set forth in Sections 2.1 and 2.2. The Construction Manager's Construction Phase responsibilities are set forth in Section 2.3. The Owner and Construction Manager may agree, in consultation with the Architect, for the Construction Phase to commence prior to completion of the Preconstruction Phase, in which case, both phases will proceed concurrently. The Construction Manager shall identify a representative authorized to act on behalf of the Construction Manager with respect to the Project.

### § 2.1 Preconstruction Phase

§ 2.1.1 The Construction Manager shall provide a preliminary evaluation of the Owner's program, schedule and construction budget requirements, each in terms of the other.

### § 2.1.2 Consultation

The Construction Manager shall schedule and conduct meetings with the Architect and Owner to discuss such matters as procedures, progress, coordination, and scheduling of the Work. The Construction Manager shall advise the Owner and the Architect on proposed site use and improvements, selection of materials, and building systems and equipment. The Construction Manager shall also provide recommendations consistent with the Project requirements to the Owner and Architect on constructability; availability of materials and labor; time requirements for procurement, installation and construction; and factors related to construction cost including, but not limited to, costs of alternative designs or materials, preliminary budgets, life-cycle data, and possible cost reductions.

§ 2.1.3 When Project requirements in Section 3.1.1 have been sufficiently identified, the Construction Manager shall prepare and periodically update a Project schedule for the Architect's review and the Owner's acceptance. The Construction Manager shall obtain the Architect's approval for the portion of the Project schedule relating to the performance of the Architect's services. The Project schedule shall coordinate and integrate the Construction Manager's services, the Architect's services, other Owner consultants' services, and the Owner's responsibilities and identify items that could affect the Project's timely completion. The updated Project schedule shall include the following: submission of the Guaranteed Maximum Price proposal; components of the Work; times of commencement and completion required of each Subcontractor; ordering and delivery of products, including those that must be ordered well in advance of construction; and the occupancy requirements of the Owner.

### § 2.1.4 Phased Construction

The Construction Manager shall provide recommendations with regard to accelerated or fast-track scheduling, procurement, or phased construction. The Construction Manager shall take into consideration cost reductions, cost information, constructability, provisions for temporary facilities and procurement and construction scheduling issues.

### § 2.1.5 Preliminary Cost Estimates

§ 2.1.5.1 Based on the preliminary design and other design criteria prepared by the Architect, the Construction Manager shall prepare preliminary estimates of the Cost of the Work or the cost of program requirements using area, volume or similar conceptual estimating techniques for the Architect's review and Owner's approval. If the Architect or Construction Manager suggests alternative materials and systems, the Construction Manager shall provide cost evaluations of those alternative materials and systems.

§ 2.1.5.2 As the Architect progresses with the preparation of the Schematic Design, Design Development and Construction Documents, the Construction Manager shall prepare and update, at appropriate intervals agreed to by the Owner, Construction Manager and Architect, estimates of the Cost of the Work of increasing detail and refinement and allowing for the further development of the design until such time as the Owner and Construction Manager agree on a Guaranteed Maximum Price for the Work. Such estimates shall be provided for the Architect's review and the Owner's approval. The Construction Manager shall inform the Owner and Architect when estimates of the Cost of the Work exceed the latest approved Project budget and make recommendations for corrective action.

### § 2.1.6 Subcontractors and Suppliers

The Construction Manager shall develop bidders' interest in the Project.

§ 2.1.7 The Construction Manager shall prepare, for the Architect's review and the Owner's acceptance, a procurement schedule for items that must be ordered well in advance of construction. The Construction Manager shall expedite and coordinate the ordering and delivery of materials that must be ordered well in advance of construction. If the Owner agrees to procure any items prior to the establishment of the Guaranteed Maximum Price, the Owner shall procure the

Init.

items on terms and conditions acceptable to the Construction Manager. Upon the establishment of the Guaranteed Maximum Price, the Owner shall assign all contracts for these items to the Construction Manager and the Construction Manager shall thereafter accept responsibility for them.

#### **§ 2.1.8 Extent of Responsibility**

The Construction Manager shall exercise reasonable care in preparing schedules and estimates. The Construction Manager, however, does not warrant or guarantee estimates and schedules except as may be included as part of the Guaranteed Maximum Price. The Construction Manager is not required to ascertain that the Drawings and Specifications are in accordance with applicable laws, statutes, ordinances, codes, rules and regulations, or lawful orders of public authorities, but the Construction Manager shall promptly report to the Architect and Owner any nonconformity discovered by or made known to the Construction Manager as a request for information in such form as the Architect may require.

#### **§ 2.1.9 Notices and Compliance with Laws**

The Construction Manager shall comply with applicable laws, statutes, ordinances, codes, rules and regulations, and lawful orders of public authorities applicable to its performance under this Contract, and with equal employment opportunity programs, and other programs as may be required by governmental and quasi governmental authorities for inclusion in the Contract Documents.

#### **§ 2.2 Guaranteed Maximum Price Proposal and Contract Time**

**§ 2.2.1** At a time to be mutually agreed upon by the Owner and the Construction Manager and in consultation with the Architect, the Construction Manager shall prepare a Guaranteed Maximum Price proposal for the Owner's review and acceptance. The Guaranteed Maximum Price in the proposal shall be the sum of the Construction Manager's estimate of the Cost of the Work, including contingencies described in Section 2.2.4, and the Construction Manager's Fee.

**§ 2.2.2** To the extent that the Drawings and Specifications are anticipated to require further development by the Architect, the Construction Manager shall provide in the Guaranteed Maximum Price for such further development consistent with the Contract Documents and reasonably inferable therefrom. Such further development does not include such things as changes in scope, systems, kinds and quality of materials, finishes or equipment, all of which, if required, shall be incorporated by Change Order.

**§ 2.2.3** The Construction Manager shall include with the Guaranteed Maximum Price proposal a written statement of its basis, which shall include the following:

- .1 A list of the Drawings and Specifications, including all Addenda thereto, and the Conditions of the Contract;
- .2 A list of the clarifications and assumptions made by the Construction Manager in the preparation of the Guaranteed Maximum Price proposal, including assumptions under Section 2.2.2, to supplement the information provided by the Owner and contained in the Drawings and Specifications;
- .3 A statement of the proposed Guaranteed Maximum Price, including a statement of the estimated Cost of the Work organized by trade categories or systems, allowances, contingency, and the Construction Manager's Fee;
- .4 The anticipated date of Substantial Completion upon which the proposed Guaranteed Maximum Price is based; and
- .5 A date by which the Owner must accept the Guaranteed Maximum Price.

**§ 2.2.4** In preparing the Construction Manager's Guaranteed Maximum Price proposal, the Construction Manager shall include its contingency for the Construction Manager's exclusive use to cover those costs considered reimbursable as the Cost of the Work but not included in a Change Order. The Guaranteed Maximum Price includes a 8% Design/Budget contingency to be controlled by the Owner. The intent of this contingency is to allow for design development and completion to occur without needing to go outside the value of the contracted early GMP. After completion of all bid packages and subcontractor awards, 100% of the remaining Design/Build contingency funds will be returned to the Owner via a change order to the Guaranteed Maximum Price and held as an Owner's contingency.

*(Paragraph deleted)*

**§ 2.2.5** Construction Contingency. The Guaranteed Maximum Price also includes a 2% Construction Contingency, to be controlled by the Construction Manager with notification to the Owner, from the start of the project until

Int.

completion if funds are drawn. 100% of the remaining Construction Contingency will be returned to the Owner at the completion of the Project.

.1 In preparing the Construction Manager's Guaranteed Maximum Price proposal, the Construction Manager will include its contingency of Two Percent (2%) of the estimated Cost of the Work for the Construction Manager's exclusive use to cover those costs considered reimbursable as the Cost of the Work but not included in a Change Order. This contingency cannot be used to reimburse lump sum general conditions coverage costs.

.2 The Construction Manager's Contingency is not allocated to any particular item of Cost of Work, may be utilized without the necessity of any Change Order, and shall be used to mitigate risk and unanticipated costs that may occur between Construction Manager's and its Subcontractor's incurred from portions of Work inadvertently not assigned to any Subcontractor, items that were not anticipated by Construction Manager at the time of Owner's approval of the Guaranteed Maximum Price Proposal, Subcontractor defaults, Construction Manager's insurance deductibles, coordination of the work of Subcontractors with Owner's Separate Contractors, corrections in the Work provided Construction Manager has exhausted all reasonable means short of arbitration to obtain correction from any responsible Subcontractors, and costs required to maintain the Project Schedule (not due to the Owner's or Architects actions or failure to act other excusable delays as defined by Section 8.3.1 of the General Conditions ("Excusable Delays")).

.3 The Construction Manager's Contingency cannot be used to offset or fund Owner-ordered changes in the Work, design errors, omissions, incompleteness or lack of design coordination, changes in scope, systems, kinds and quality of materials, finishes or equipment, costs caused by Excusable Delays, costs of addressing differing or concealed conditions, costs of Handling Hazardous Substances not brought to site by Construction Manager, costs of industry-wide shortages or industry-wide price escalations or any other costs or damages for which Construction Manager is entitled to an increase in the Guaranteed Maximum Price.

.4 Whenever any of the Contract Documents use the terms or phrases "at Contractor's (or Construction Manager's) sole expense", "at no cost to Owner", "Contractor shall pay to Owner", "Owner may deduct", "a Change Order deducting", "Contractor shall bear", "to be borne by Contractor" or the like, such terms or phrases shall be deemed modified by the following "subject to Construction Manager's right to use Construction Manager's Contingency, pursuant to the terms and conditions of Section 2.2.5 of the Agreement."

.5 Construction Manager shall maintain a "Construction Manager's Contingency Expense Log" which shall contain a list and description of all items paid out of the Construction Manager's Contingency and showing movement from the Construction Manager's Contingency to other line items. Construction Manager shall update and submit a copy of such Construction Manager's Contingency Expense Log and supporting documentation reasonably acceptable to Owner along with each application for payment and at any other time when reasonably requested by Owner."

§ 2.2.6 The Construction Manager shall meet with the Owner and Architect to review the Guaranteed Maximum Price proposal. In the event that the Owner and Architect discover any inconsistencies or inaccuracies in the information presented, they shall promptly notify the Construction Manager, who shall make appropriate adjustments to the Guaranteed Maximum Price proposal, its basis, or both.

§ 2.2.7 If the Owner notifies the Construction Manager that the Owner has accepted the Guaranteed Maximum Price proposal in writing before the date specified in the Guaranteed Maximum Price proposal, the Guaranteed Maximum Price proposal shall be deemed effective without further acceptance from the Construction Manager. Following acceptance of a Guaranteed Maximum Price, the Owner and Construction Manager shall execute the Guaranteed Maximum Price Amendment amending this Agreement, a copy of which the Owner shall provide to the Architect. The Guaranteed Maximum Price Amendment shall set forth the agreed upon Guaranteed Maximum Price with the information and assumptions upon which it is based.

§ 2.2.8 The Construction Manager shall not incur any cost to be reimbursed as part of the Cost of the Work prior to the commencement of the Construction Phase, unless the Owner provides prior written authorization for such costs.

§ 2.2.9 The Owner shall authorize the Architect to provide the revisions to the Drawings and Specifications to incorporate the agreed upon assumptions and clarifications contained in the Guaranteed Maximum Price Amendment. The Owner shall promptly furnish those revised Drawings and Specifications to the Construction Manager as they are revised. The Construction Manager shall notify the Owner and Architect of any inconsistencies between the Guaranteed Maximum Price Amendment and the revised Drawings and Specifications.

Init.

§ 2.2.10 The Construction Manager shall include in the Guaranteed Maximum Price all sales, consumer, use and similar taxes for the Work provided by the Construction Manager that are legally enacted, whether or not yet effective, at the time the Guaranteed Maximum Price Amendment is executed. The City of Evanston is tax exempt and Construction Manager must submit sales tax exemption information prior to purchases to prevent sales tax from being assessed in the subject transaction.

### § 2.3 Construction Phase

#### § 2.3.1 General

§ 2.3.1.1 For purposes of Section 8.1.2 of A201–2007, the date of commencement of the Work shall mean the date of commencement of the Construction Phase.

§ 2.3.1.2 The Construction Phase shall commence upon the Owner's acceptance of the Construction Manager's Guaranteed Maximum Price proposal or the Owner's issuance of a Notice to Proceed, whichever occurs earlier.

#### § 2.3.2 Administration

§ 2.3.2.1 Those portions of the Work that the Construction Manager does not customarily perform with the Construction Manager's own personnel shall be performed under subcontracts or by other appropriate agreements with the Construction Manager. The Owner may designate specific persons from whom, or entities from which, the Construction Manager shall obtain bids. The Construction Manager shall obtain bids from Subcontractors and from suppliers of materials or equipment fabricated especially for the Work and shall deliver such bids to the Architect. The Owner shall then determine, with the advice of the Construction Manager and the Architect, which bids will be accepted. The Construction Manager shall not be required to contract with anyone to whom the Construction Manager has reasonable objection.

§ 2.3.2.2 If the Guaranteed Maximum Price has been established and when a specific bidder (1) is recommended to the Owner by the Construction Manager, (2) is qualified to perform that portion of the Work, and (3) has submitted a bid that conforms to the requirements of the Contract Documents without reservations or exceptions, but the Owner requires that another bid be accepted, then the Construction Manager may require that a Change Order be issued to adjust the Contract Time and the Guaranteed Maximum Price by the difference between the bid of the person or entity recommended to the Owner by the Construction Manager and the amount and time requirement of the subcontract or other agreement actually signed with the person or entity designated by the Owner.

§ 2.3.2.3 Subcontracts or other agreements shall conform to the applicable payment provisions of this Agreement, and shall not be awarded on the basis of cost plus a fee without the prior consent of the Owner. If the Subcontract is awarded on a cost plus fee basis, the Construction Manager shall provide in the Subcontract for the Owner to receive the same audit rights with regard to the Subcontractor as the Owner receives with regard to the Construction Manager in Section 6.11 below.

§ 2.3.2.4 If the Construction Manager recommends a specific bidder that may be considered a "related party" according to Section 6.10, then the Construction Manager shall promptly notify the Owner in writing of such relationship and notify the Owner of the specific nature of the contemplated transaction, according to Section 6.10.2.

§ 2.3.2.5 The Construction Manager shall schedule and conduct meetings to discuss such matters as procedures, progress, coordination, scheduling, and status of the Work. The Construction Manager shall prepare and promptly distribute minutes to the Owner and Architect.

§ 2.3.2.6 Upon the execution of the Guaranteed Maximum Price Amendment, the Construction Manager shall prepare and submit to the Owner and Architect a construction schedule for the Work and submittal schedule in accordance with Section 3.10 of A201–2007.

§ 2.3.2.7 The Construction Manager shall record the progress of the Project. On a monthly basis, or otherwise as agreed to by the Owner, the Construction Manager shall submit written progress reports to the Owner and Architect, showing percentages of completion and other information required by the Owner. The Construction Manager shall also keep, and make available to the Owner and Architect, a daily log containing a record for each day of weather, portions of the Work in progress, number of workers on site, identification of equipment on site, problems that might affect progress of the work, accidents, injuries, and other information required by the Owner.



§ 2.3.2.8 The Construction Manager shall develop a system of cost control for the Work, including regular monitoring of actual costs for activities in progress and estimates for uncompleted tasks and proposed changes. The Construction Manager shall identify variances between actual and estimated costs and report the variances to the Owner and Architect and shall provide this information in its monthly reports to the Owner and Architect, in accordance with Section 2.3.2.7 above.

#### § 2.4 Professional Services

Section 3.12.10 of A201-2007 shall apply to both the Preconstruction and Construction Phases.

#### § 2.5 Hazardous Materials

Section 10.3 of A201-2007 shall apply to both the Preconstruction and Construction Phases.

### ARTICLE 3 OWNER'S RESPONSIBILITIES

#### § 3.1 Information and Services Required of the Owner

§ 3.1.1 The Owner shall provide information with reasonable promptness, regarding requirements for and limitations on the Project, including a written program which shall set forth the Owner's objectives, constraints, and criteria, including schedule, space requirements and relationships, flexibility and expandability, special equipment, systems, sustainability and site requirements.

§ 3.1.2 Prior to the execution of the Guaranteed Maximum Price Amendment, the Construction Manager may request in writing that the Owner provide reasonable evidence that the Owner has made financial arrangements to fulfill the Owner's obligations under the Contract. Thereafter, the Construction Manager may only request such evidence if (1) the Owner fails to make payments to the Construction Manager as the Contract Documents require, (2) a change in the Work materially changes the Contract Sum, or (3) the Construction Manager identifies in writing a reasonable concern regarding the Owner's ability to make payment when due. The Owner shall furnish such evidence as a condition precedent to commencement or continuation of the Work or the portion of the Work affected by a material change. After the Owner furnishes the evidence, the Owner shall not materially vary such financial arrangements without prior notice to the Construction Manager and Architect.

§ 3.1.3 The Owner shall establish and periodically update the Owner's budget for the Project, including (1) the budget for the Cost of the Work as defined in Section 6.1.1, (2) the Owner's other costs, and (3) reasonable contingencies related to all of these costs. If the Owner significantly increases or decreases the Owner's budget for the Cost of the Work, the Owner shall notify the Construction Manager and Architect. The Owner and the Architect, in consultation with the Construction Manager, shall thereafter agree to a corresponding change in the Project's scope and quality.

§ 3.1.4 **Structural and Environmental Tests, Surveys and Reports.** During the Preconstruction Phase, the Owner shall furnish the following information or services with reasonable promptness. The Owner shall also furnish any other information or services under the Owner's control and relevant to the Construction Manager's performance of the Work with reasonable promptness after receiving the Construction Manager's written request for such information or services. The Construction Manager shall be entitled to rely on the accuracy of information and services furnished by the Owner but shall exercise proper precautions relating to the safe performance of the Work.

§ 3.1.4.1 The Owner shall furnish tests, inspections and reports required by law and as otherwise agreed to by the parties, such as structural, mechanical, and chemical tests, tests for air and water pollution, and tests for hazardous materials.

§ 3.1.4.2 The Owner shall furnish surveys describing physical characteristics, legal limitations and utility locations for the site of the Project, and a legal description of the site. The surveys and legal information shall include, as applicable, grades and lines of streets, alleys, pavements and adjoining property and structures; designated wetlands; adjacent drainage; rights-of-way, restrictions, easements, encroachments, zoning, deed restrictions, boundaries and contours of the site; locations, dimensions and necessary data with respect to existing buildings, other improvements and trees; and information concerning available utility services and lines, both public and private, above and below grade, including inverts and depths. All the information on the survey shall be referenced to a Project benchmark.

§ 3.1.4.3 The Owner, when such services are requested, shall furnish services of geotechnical engineers, which may include but are not limited to test borings, test pits, determinations of soil bearing values, percolation tests, evaluations

Init.

of hazardous materials, seismic evaluation, ground corrosion tests and resistivity tests, including necessary operations for anticipating subsoil conditions, with written reports and appropriate recommendations.

§ 3.1.4.4 During the Construction Phase, the Owner shall furnish information or services required of the Owner by the Contract Documents with reasonable promptness. The Owner shall also furnish any other information or services under the Owner's control and relevant to the Construction Manager's performance of the Work with reasonable promptness after receiving the Construction Manager's written request for such information or services.

### § 3.2 Owner's Designated Representative

The Owner shall identify a representative authorized to act on behalf of the Owner with respect to the Project. The Owner's representative shall render decisions promptly and furnish information expeditiously, so as to avoid unreasonable delay in the services or Work of the Construction Manager. Except as otherwise provided in Section 4.2.1 of A201-2007, the Architect does not have such authority. The term "Owner" means the Owner or the Owner's authorized representative.

§ 3.2.1 Legal Requirements. The Owner shall furnish all legal, insurance and accounting services, including auditing services, that may be reasonably necessary at any time for the Project to meet the Owner's needs and interests.

### § 3.3 Architect

The Owner shall retain an Architect to provide services, duties and responsibilities as described in AIA Document B133™-2014, Standard Form of Agreement Between Owner and Architect, Construction Manager as Constructor Edition. The Owner shall provide the Construction Manager a copy of the executed agreement between the Owner and the Architect, and any further modifications to the agreement.

## ARTICLE 4 COMPENSATION AND PAYMENTS FOR PRECONSTRUCTION PHASE SERVICES

### § 4.1 Compensation

§ 4.1.1 For the Construction Manager's Preconstruction Phase services, the Owner shall compensate the Construction Manager as follows:

§ 4.1.2 For the Construction Manager's Preconstruction Phase services described in Sections 2.1 and 2.2:  
*(Insert amount of, or basis for, compensation and include a list of reimbursable cost items, as applicable.)*

§ 4.1.3 If the Preconstruction Phase services covered by this Agreement have not been completed within ( ) months of the date of this Agreement, through no fault of the Construction Manager, the Construction Manager's compensation for Preconstruction Phase services shall be equitably adjusted.

§ 4.1.4 Compensation based on Direct Personnel Expense includes the direct salaries of the Construction Manager's personnel providing Preconstruction Phase services on the Project and the Construction Manager's costs for the mandatory and customary contributions and benefits related thereto, such as employment taxes and other statutory employee benefits, insurance, sick leave, holidays, vacations, employee retirement plans and similar contributions.

### § 4.2 Payments

§ 4.2.1 Unless otherwise agreed, payments for services shall be made monthly in proportion to services performed.

§ 4.2.2 Payments are due and payable upon presentation of the Construction Manager's  
*(Paragraphs deleted)*

invoice and in accordance with the Illinois Local Government Prompt Payment Act, 50 ILCS 505/et seq. Any bill approved for payment pursuant to Section 3 shall be paid within 30 days after the date of approval.

## ARTICLE 5 COMPENSATION FOR CONSTRUCTION PHASE SERVICES

§ 5.1 For the Construction Manager's performance of the Work as described in Section 2.3, the Owner shall pay the Construction Manager the Contract Sum in current funds. The Contract Sum is the Cost of the Work as defined in Section 6.1.1 plus the Construction Manager's Fee.

§ 5.1.1 The Construction Manager's Fee:

Init.

*(State a lump sum, percentage of Cost of the Work or other provision for determining the Construction Manager's Fee.)*

Task 1 (preconstruction services): \$41,510.00 not to exceed.

Task 2 (construction services): 1.75% times the Cost of the Work.

**§ 5.1.2** The method of adjustment of the Construction Manager's Fee for changes in the Work:

For changes in work that result in a net additive cost but no schedule impact, construction manager's fee of 3% times the cost of the work will be included. For changes in the work that result in a change of the project completion date, general conditions cost will be included as a cost of the change work.

There shall be no credit of Construction Manager's Fee on changes in work that result in a net credit.

In addition to the CM Fee markup, the following markups will be included on changes in the work...

- General Liability Insurance - 1% times the cost of the work
- Subcontractor Default Insurance - 1.1% times the cost of subcontractor work
- Payment and Performance Bond - 0.525% times the cost of the work
- General Conditions - no additional markup beyond CM fee markup for changes that do not impact project schedule. For changes that modify project schedule, general conditions will be included as actual cost of the work.

**§ 5.1.3** Limitations, if any, on a Subcontractor's overhead and profit for increases in the cost of its portion of the Work:

Subcontractor markup on increases in the cost of its portion of work limited to 5% overhead and 5% profit.

**§ 5.1.4** Rental rates for Construction Manager-owned equipment shall not exceed ninety percent ( 90%) of the AED Green Book.

**§ 5.1.5** Unit prices, if any:

*(Identify and state the unit price; state the quantity limitations, if any, to which the unit price will be applicable.)*

Item	Units and Limitations	Price per Unit (\$0.00)
To be included with GMP amendment		

## **§ 5.2 Guaranteed Maximum Price**

**§ 5.2.1** The Construction Manager guarantees that the Contract Sum shall not exceed the Guaranteed Maximum Price set forth in the Guaranteed Maximum Price Amendment, as it is amended from time to time. To the extent the Cost of the Work exceeds the Guaranteed Maximum Price, the Construction Manager shall bear such costs in excess of the Guaranteed Maximum Price without reimbursement or additional compensation from the Owner.

*(Paragraphs deleted)*

**§ 5.2.2** The Guaranteed Maximum Price is subject to additions and deductions by Change Order as provided in the Contract Documents and the Date of Substantial Completion shall be subject to adjustment as provided in the Contract Documents.

## **§ 5.3 Changes in the Work**

**§ 5.3.1** The Owner may, without invalidating the Contract, order changes in the Work within the general scope of the Contract consisting of additions, deletions or other revisions. The Owner shall issue such changes in writing. The Architect may make minor changes in the Work as provided in Section 7.4 of AIA Document A201-2007, General Conditions of the Contract for Construction. The Construction Manager shall be entitled to an equitable adjustment in the Contract Time as a result of changes in the Work.

**§ 5.3.2** Adjustments to the Guaranteed Maximum Price on account of changes in the Work subsequent to the execution of the Guaranteed Maximum Price Amendment may be determined by any of the methods listed in Section 7.3.3 of AIA Document A201-2007, General Conditions of the Contract for Construction.

§ 5.3.3 In calculating adjustments to subcontracts (except those awarded with the Owner's prior consent on the basis of cost plus a fee), the terms "cost" and "fee" as used in Section 7.3.3.3 of AIA Document A201-2007 and the term "costs" as used in Section 7.3.7 of AIA Document A201-2007 shall have the meanings assigned to them in AIA Document A201-2007 and shall not be modified by Sections 5.1 and 5.2, Sections 6.1 through 6.7, and Section 6.8 of this Agreement. Adjustments to subcontracts awarded with the Owner's prior consent on the basis of cost plus a fee shall be calculated in accordance with the terms of those subcontracts.

§ 5.3.4 In calculating adjustments to the Guaranteed Maximum Price, the terms "cost" and "costs" as used in the above-referenced provisions of AIA Document A201-2007 shall mean the Cost of the Work as defined in Sections 6.1 to 6.7 of this Agreement and the term "fee" shall mean the Construction Manager's Fee as defined in Section 5.1 of this Agreement.

§ 5.3.5 If no specific provision is made in Section 5.1.2 for adjustment of the Construction Manager's Fee in the case of changes in the Work, or if the extent of such changes is such, in the aggregate, that application of the adjustment provisions of Section 5.1.2 will cause substantial inequity to the Owner or Construction Manager, the Construction Manager's Fee shall be equitably adjusted on the same basis that was used to establish the Fee for the original Work, and the Guaranteed Maximum Price shall be adjusted accordingly.

## ARTICLE 6 COST OF THE WORK FOR CONSTRUCTION PHASE

### § 6.1 Costs to Be Reimbursed

§ 6.1.1 The term Cost of the Work shall mean costs necessarily incurred by the Construction Manager in the proper performance of the Work. Such costs shall be at rates not higher than the standard paid at the place of the Project except with prior consent of the Owner. The Cost of the Work shall include only the items set forth in Sections 6.1 through 6.7.

§ 6.1.2 Where any cost is subject to the Owner's prior approval, the Construction Manager shall obtain this approval prior to incurring the cost. The parties shall endeavor to identify any such costs prior to executing Guaranteed Maximum Price Amendment.

### § 6.2 Labor Costs

§ 6.2.1 Wages of construction workers directly employed by the Construction Manager to perform the construction of the Work at the site or, with the Owner's prior approval, at off-site workshops.

§ 6.2.2 Wages or salaries of the Construction Manager's supervisory and administrative personnel when stationed at the site with the Owner's prior approval.

*(If it is intended that the wages or salaries of certain personnel stationed at the Construction Manager's principal or other offices shall be included in the Cost of the Work, identify in Section 11.5, the personnel to be included, whether for all or only part of their time, and the rates at which their time will be charged to the Work.)*

§ 6.2.3 Wages and salaries of the Construction Manager's supervisory or administrative personnel engaged at factories, workshops or on the road, in expediting the production or transportation of materials or equipment required for the Work, but only for that portion of their time required for the Work.

§ 6.2.4 Costs paid or incurred by the Construction Manager for taxes, insurance, contributions, assessments and benefits required by law or collective bargaining agreements and, for personnel not covered by such agreements, customary benefits such as sick leave, medical and health benefits, holidays, vacations and pensions, provided such costs are based on wages and salaries included in the Cost of the Work under Sections 6.2.1 through 6.2.3.

§ 6.2.5 Bonuses, profit sharing, incentive compensation and any other discretionary payments paid to anyone hired by the Construction Manager or paid to any Subcontractor or vendor, with the Owner's prior approval.

### § 6.3 Subcontract Costs

Payments made by the Construction Manager to Subcontractors in accordance with the requirements of the subcontracts.

Init.

**§ 6.4 Costs of Materials and Equipment Incorporated in the Completed Construction**

**§ 6.4.1** Costs, including transportation and storage, of materials and equipment incorporated or to be incorporated in the completed construction.

**§ 6.4.2** Costs of materials described in the preceding Section 6.4.1 in excess of those actually installed to allow for reasonable waste and spoilage. Unused excess materials, if any, shall become the Owner's property at the completion of the Work or, at the Owner's option, shall be sold by the Construction Manager. Any amounts realized from such sales shall be credited to the Owner as a deduction from the Cost of the Work.

**§ 6.5 Costs of Other Materials and Equipment, Temporary Facilities and Related Items**

**§ 6.5.1** Costs of transportation, storage, installation, maintenance, dismantling and removal of materials, supplies, temporary facilities, machinery, equipment and hand tools not customarily owned by construction workers that are provided by the Construction Manager at the site and fully consumed in the performance of the Work. Costs of materials, supplies, temporary facilities, machinery, equipment and tools that are not fully consumed shall be based on the cost or value of the item at the time it is first used on the Project site less the value of the item when it is no longer used at the Project site. Costs for items not fully consumed by the Construction Manager shall mean fair market value.

**§ 6.5.2** Rental charges for temporary facilities, machinery, equipment and hand tools not customarily owned by construction workers that are provided by the Construction Manager at the site and costs of transportation, installation, minor repairs, dismantling and removal. The total rental cost of any Construction Manager-owned item may not exceed the purchase price of any comparable item. Rates of Construction Manager-owned equipment and quantities of equipment shall be subject to the Owner's prior approval.

**§ 6.5.3** Costs of removal of debris from the site of the Work and its proper and legal disposal.

**§ 6.5.4** Costs of document reproductions, facsimile transmissions and long-distance telephone calls, postage and parcel delivery charges, telephone service at the site and reasonable petty cash expenses of the site office.

**§ 6.5.5** That portion of the reasonable expenses of the Construction Manager's supervisory or administrative personnel incurred while traveling in discharge of duties connected with the Work.

**§ 6.5.6** Costs of materials and equipment suitably stored off the site at a mutually acceptable location, subject to the Owner's prior approval.

**§ 6.6 Miscellaneous Costs**

**§ 6.6.1** Premiums for that portion of insurance and bonds required by the Contract Documents that can be directly attributed to this Contract. Self-insurance for either full or partial amounts of the coverages required by the Contract Documents, with the Owner's prior approval.

**§ 6.6.2** Sales, use or similar taxes imposed by a governmental authority that are related to the Work and for which the Construction Manager is liable. The City of Evanston is tax exempt and construction manager will submit sales tax exemption information prior to purchases to prevent sales tax from being assessed in the subject transaction. Federal Excise Tax does not apply to materials purchased by the City of Evanston by virtue of Exemption Certificate No. A-208762, Illinois Retailers' Occupation Tax, Use Tax, and Municipal Retailers' Occupation Tax do not apply to materials or services purchased by the City of Evanston by virtue of Statute. The City of Evanston is exempt from Illinois Sales Tax by virtue of Exemption Identification number E9998-1750-07. The City's federal tax ID number is 36-6005870.

**§ 6.6.3** Fees and assessments for the building permit and for other permits, licenses and inspections for which the Construction Manager is required by the Contract Documents to pay. All fees typically assessed by the City of Evanston for the construction of this project will be waived. This waiver does not apply to any other government agencies and Construction Manager must pay the applicable fees assessed.

**§ 6.6.4** Fees of laboratories for tests required by the Contract Documents, except those related to defective or nonconforming Work for which reimbursement is excluded by Section 13.5.3 of AIA Document A201-2007 or by other provisions of the Contract Documents, and which do not fall within the scope of Section 6.7.3.

§ 6.6.5 Royalties and license fees paid for the use of a particular design, process or product required by the Contract Documents; the cost of defending suits or claims for infringement of patent rights arising from such requirement of the Contract Documents; and payments made in accordance with legal judgments against the Construction Manager resulting from such suits or claims and payments of settlements made with the Owner's consent. However, such costs of legal defenses, judgments and settlements shall not be included in the calculation of the Construction Manager's Fee or subject to the Guaranteed Maximum Price. If such royalties, fees and costs are excluded by the last sentence of Section 3.17 of AIA Document A201-2007 or other provisions of the Contract Documents, then they shall not be included in the Cost of the Work.

§ 6.6.6 Costs for electronic equipment and software, directly related to the Work with the Owner's prior approval.

§ 6.6.7 Deposits lost for causes other than the Construction Manager's negligence or failure to fulfill a specific responsibility in the Contract Documents.

§ 6.6.8 Legal, mediation and arbitration costs, including attorneys' fees, other than those arising from disputes between the Owner and Construction Manager, reasonably incurred by the Construction Manager after the execution of this Agreement in the performance of the Work and with the Owner's prior approval, which shall not be unreasonably withheld.

§ 6.6.9 Subject to the Owner's prior approval, expenses incurred in accordance with the Construction Manager's standard written personnel policy for relocation and temporary living allowances of the Construction Manager's personnel required for the Work.

#### § 6.7 Other Costs and Emergencies

§ 6.7.1 Other costs incurred in the performance of the Work if, and to the extent, approved in advance in writing by the Owner.

§ 6.7.2 Costs incurred in taking action to prevent threatened damage, injury or loss in case of an emergency affecting the safety of persons and property, as provided in Section 10.4 of AIA Document A201-2007.

§ 6.7.3 Costs of repairing or correcting damaged or nonconforming Work executed by the Construction Manager, Subcontractors or suppliers, provided that such damaged or nonconforming Work was not caused by negligence or failure to fulfill a specific responsibility of the Construction Manager and only to the extent that the cost of repair or correction is not recovered by the Construction Manager from insurance, sureties, Subcontractors, suppliers, or others.

§ 6.7.4 The costs described in Sections 6.1 through 6.7 shall be included in the Cost of the Work, notwithstanding any provision of AIA Document A201-2007 or other Conditions of the Contract which may require the Construction Manager to pay such costs, unless such costs are excluded by the provisions of Section 6.8.

#### § 6.8 Costs Not To Be Reimbursed

§ 6.8.1 The Cost of the Work shall not include the items listed below:

- .1 Salaries and other compensation of the Construction Manager's personnel stationed at the Construction Manager's principal office or offices other than the site office, except as specifically provided in Section 6.2, or as may be provided in Article 11;
- .2 Expenses of the Construction Manager's principal office and offices other than the site office;
- .3 Overhead and general expenses, except as may be expressly included in Sections 6.1 to 6.7;
- .4 The Construction Manager's capital expenses, including interest on the Construction Manager's capital employed for the Work;
- .5 Except as provided in Section 6.7.3 of this Agreement, costs due to the negligence or failure of the Construction Manager, Subcontractors and suppliers or anyone directly or indirectly employed by any of them or for whose acts any of them may be liable to fulfill a specific responsibility of the Contract;
- .6 Any cost not specifically and expressly described in Sections 6.1 to 6.7;
- .7 Costs, other than costs included in Change Orders approved by the Owner, that would cause the Guaranteed Maximum Price to be exceeded; and
- .8 Costs for services incurred during the Preconstruction Phase.

### **§ 6.9 Discounts, Rebates and Refunds**

**§ 6.9.1** Cash discounts obtained on payments made by the Construction Manager shall accrue to the Owner if (1) before making the payment, the Construction Manager included them in an Application for Payment and received payment from the Owner, or (2) the Owner has deposited funds with the Construction Manager with which to make payments; otherwise, cash discounts shall accrue to the Construction Manager. Trade discounts, rebates, refunds and amounts received from sales of surplus materials and equipment shall accrue to the Owner, and the Construction Manager shall make provisions so that they can be obtained.

**§ 6.9.2** Amounts that accrue to the Owner in accordance with the provisions of Section 6.9.1 shall be credited to the Owner as a deduction from the Cost of the Work.

### **§ 6.10 Related Party Transactions**

**§ 6.10.1** For purposes of Section 6.10, the term "related party" shall mean a parent, subsidiary, affiliate or other entity having common ownership or management with the Construction Manager; any entity in which any stockholder in, or management employee of, the Construction Manager owns any interest in excess of ten percent in the aggregate; or any person or entity which has the right to control the business or affairs of the Construction Manager. The term "related party" includes any member of the immediate family of any person identified above.

**§ 6.10.2** If any of the costs to be reimbursed arise from a transaction between the Construction Manager and a related party, the Construction Manager shall notify the Owner of the specific nature of the contemplated transaction, including the identity of the related party and the anticipated cost to be incurred, before any such transaction is consummated or cost incurred. If the Owner, after such notification, authorizes the proposed transaction, then the cost incurred shall be included as a cost to be reimbursed, and the Construction Manager shall procure the Work, equipment, goods or service from the related party, as a Subcontractor, according to the terms of Sections 2.3.2.1, 2.3.2.2 and 2.3.2.3. If the Owner fails to authorize the transaction, the Construction Manager shall procure the Work, equipment, goods or service from some person or entity other than a related party according to the terms of Sections 2.3.2.1, 2.3.2.2 and 2.3.2.3.

### **§ 6.11 Accounting Records**

The Construction Manager shall keep full and detailed records and accounts related to the cost of the Work and exercise such controls as may be necessary for proper financial management under this Contract and to substantiate all costs incurred. The accounting and control systems shall be satisfactory to the Owner. The Owner and the Owner's auditors shall, during regular business hours and upon reasonable notice, be afforded access to, and shall be permitted to audit and copy, the Construction Manager's records and accounts, including complete documentation supporting accounting entries, books, correspondence, instructions, drawings, receipts, subcontracts, Subcontractor's proposals, purchase orders, vouchers, memoranda and other data relating to this Contract. The Construction Manager shall preserve these records for a period of three years after final payment, or for such longer period as may be required by law.

## **ARTICLE 7 PAYMENTS FOR CONSTRUCTION PHASE SERVICES**

### **§ 7.1 Progress Payments**

**§ 7.1.1** Based upon Applications for Payment submitted to the Architect by the Construction Manager and Certificates for Payment issued by the Architect, the Owner shall make progress payments on account of the Contract Sum to the Construction Manager as provided below and elsewhere in the Contract Documents.

**§ 7.1.2** The period covered by each Application for Payment shall be one calendar month ending on the last day of the month, or as follows:

*(Paragraphs deleted)*

**§ 7.1.3**[Intentionally deleted]

**§ 7.1.4** With each Application for Payment, the Construction Manager shall submit payrolls, petty cash accounts, receipted invoices or invoices with check vouchers attached, and any other evidence required by the Owner or Architect to demonstrate that cash disbursements already made by the Construction Manager on account of the Cost of the Work equal or exceed progress payments already received by the Construction Manager, less that portion of those

Init.

payments attributable to the Construction Manager's Fee, plus payrolls for the period covered by the present Application for Payment.

§ 7.1.5 Each Application for Payment shall be based on the most recent schedule of values submitted by the Construction Manager in accordance with the Contract Documents. The schedule of values shall allocate the entire Guaranteed Maximum Price among the various portions of the Work, except that the Construction Manager's Fee shall be shown as a single separate item. The schedule of values shall be prepared in such form and supported by such data to substantiate its accuracy as the Architect may require. This schedule, unless objected to by the Architect, shall be used as a basis for reviewing the Construction Manager's Applications for Payment.

§ 7.1.6 Applications for Payment shall show the percentage of completion of each portion of the Work as of the end of the period covered by the Application for Payment. The percentage of completion shall be the lesser of (1) the percentage of that portion of the Work which has actually been completed, or (2) the percentage obtained by dividing (a) the expense that has actually been incurred by the Construction Manager on account of that portion of the Work for which the Construction Manager has made or intends to make actual payment prior to the next Application for Payment by (b) the share of the Guaranteed Maximum Price allocated to that portion of the Work in the schedule of values.

§ 7.1.7 Subject to other provisions of the Contract Documents, the amount of each progress payment shall be computed as follows:

- .1 The City will withhold 10% retention on all progress payments. This 10% retention includes: construction manager's fee, general conditions, general requirements, construction manager's self-performed work, all subcontractor work and all supplier materials. The City will review each request for progress payments after it receives partial lien waivers for the requested progress payment. The City will disburse the remaining 10% on all progress payments only after punch list work is complete, final lien waivers, certified payroll, warranties, and other close out documents are reviewed and approved by the City. Neither the final payment nor any part of any retained percentages, shall become due until the contractor, delivers to the City, a complete release of all liens arising out of this contract, or receipts in full in lieu thereof and, if required in either case, an affidavit that so far as it has knowledge or information the releases and receipts include all the labor and material for which a lien could be filed. If any lien remains unsatisfied after all payments are made the contractor shall refund to the City all moneys that the latter may be compelled to pay in discharging such a lien, including all costs and attorney's fees. Construction manager shall also submit trailing lien waivers as a condition of approval of each pay application.
- .2 Prior to final payment, contractor shall fully restore all property disturbed or damaged during the course of this work. This includes, but is not limited to public property, (walks, curbs, roadways, trees, etc.) private property, and utilities. This shall also include removal of temporary facilities erected during the course of this contract and restoration of these areas. All restoration work shall be subject to the approval of the City and shall restore the property to a condition at least equal to that existing prior to the start of this contract. All restoration work of property damaged by contractor shall be accomplished at the sole expense of the contractor.
- .3 The payments are computed by taking that portion of the Guaranteed Maximum Price properly allocable to completed Work as determined by multiplying the percentage of completion of each portion of the Work by the share of the Guaranteed Maximum Price allocated to that portion of the Work in the schedule of values. Pending final determination of cost to the Owner of changes in the Work, amounts not in dispute shall be included as provided in Section 7.3.9 of AIA Document A201-2007;
- .4 Add that portion of the Guaranteed Maximum Price properly allocable to materials and equipment delivered and suitably stored at the site for subsequent incorporation in the Work, or if approved in advance by the Owner, suitably stored off the site at a location agreed upon in writing;
- .5 Add the Construction Manager's Fee, less retainage of ten percent (10%). The Construction Manager's Fee shall be computed upon the Cost of the Work at the rate stated in Section 5.1 or, if the Construction Manager's Fee is stated as a fixed sum in that Section, shall be an amount that bears the same ratio to that fixed-sum fee as the Cost of the Work bears to a reasonable estimate of the probable Cost of the Work upon its completion;

Init.



- .6 Subtract retainage of ten percent (10 %) from that portion of the Work that the Construction Manager self-performs;
- .7 Subtract the aggregate of previous payments made by the Owner;
- .8 Subtract the shortfall, if any, indicated by the Construction Manager in the documentation required by Section 7.1.4 to substantiate prior Applications for Payment, or resulting from errors subsequently discovered by the Owner's auditors in such documentation; and
- .10 Subtract amounts, if any, for which the Architect has withheld or nullified a Certificate for Payment as provided in Section 9.5 of AIA Document A201-2007.

§ 7.1.8 The Owner and Construction Manager shall agree upon (1) a mutually acceptable procedure for review and approval of payments to Subcontractors and (2) the percentage of retainage held on Subcontracts, and the Construction Manager shall execute subcontracts in accordance with those agreements.

§ 7.1.9 Except with the Owner's prior approval, the Construction Manager shall not make advance payments to suppliers for materials or equipment which have not been delivered and stored at the site.

§ 7.1.10 In taking action on the Construction Manager's Applications for Payment, the Architect shall be entitled to rely on the accuracy and completeness of the information furnished by the Construction Manager and shall not be deemed to represent that the Architect has made a detailed examination, audit or arithmetic verification of the documentation submitted in accordance with Section 7.1.4 or other supporting data; that the Architect has made exhaustive or continuous on-site inspections; or that the Architect has made examinations to ascertain how or for what purposes the Construction Manager has used amounts previously paid on account of the Contract. Such examinations, audits and verifications, if required by the Owner, will be performed by the Owner's auditors acting in the sole interest of the Owner.

## § 7.2 Final Payment

§ 7.2.1 Final payment, constituting the entire unpaid balance of the Contract Sum, shall be made by the Owner to the Construction Manager  
(Paragraphs deleted)

in accordance with the statutory requirements of the Illinois Prompt Payment Act and pursuant to the contract schedule established by the parties.

§ 7.2.2 The Owner's auditors will review and report in writing on the Construction Manager's final accounting within 30 days after delivery of the final accounting to the Architect by the Construction Manager. Based upon such Cost of the Work as the Owner's auditors report to be substantiated by the Construction Manager's final accounting, and provided the other conditions of Section 7.2.1 have been met, the Architect will, within seven days after receipt of the written report of the Owner's auditors, either issue to the Owner a final Certificate for Payment with a copy to the Construction Manager, or notify the Construction Manager and Owner in writing of the Architect's reasons for withholding a certificate as provided in Section 9.5.1 of the AIA Document A201-2007. The time periods stated in this Section supersede those stated in Section 9.4.1 of the AIA Document A201-2007. The Architect is not responsible for verifying the accuracy of the Construction Manager's final accounting.

§ 7.2.3 If the Owner's auditors report the Cost of the Work as substantiated by the Construction Manager's final accounting to be less than claimed by the Construction Manager, the Construction Manager shall be entitled to request mediation of the disputed amount without seeking an initial decision pursuant to Section 15.2 of A201-2007. A request for mediation shall be made by the Construction Manager within 30 days after the Construction Manager's receipt of a copy of the Architect's final Certificate for Payment. Failure to request mediation within this 30-day period shall result in the substantiated amount reported by the Owner's auditors becoming binding on the Construction Manager. Pending a final resolution of the disputed amount, the Owner shall pay the Construction Manager the amount certified in the Architect's final Certificate for Payment.

§ 7.2.4 If, subsequent to final payment and at the Owner's request, the Construction Manager incurs costs described in Section 6.1.1 and not excluded by Section 6.8 to correct defective or nonconforming Work, the Owner shall reimburse the Construction Manager such costs and the Construction Manager's Fee applicable thereto on the same basis as if such costs had been incurred prior to final payment, but not in excess of the Guaranteed Maximum Price. If the Construction Manager has participated in savings as provided in Section 5.2.1, the amount of such savings shall be

Init.

recalculated and appropriate credit given to the Owner in determining the net amount to be paid by the Owner to the Construction Manager.

#### **ARTICLE 8 INSURANCE AND BONDS**

For all phases of the Project, the Construction Manager and the Owner shall purchase and maintain insurance, and the Construction Manager shall provide bonds as set forth in Article 11 of AIA Document A201-2007.  
*(Paragraph deleted)*

**§8.1 INSURANCE COMPANIES:** It is agreed that any policies of insurance to be maintained by Construction Manager will be obtained from good and solvent insurance companies. Only companies with an "A" Policyholder's Rating with the Alfred Best Company will be acceptable to Landlord.

**§8.2 CONSTRUCTION MANAGER MUST OBTAIN GENERAL LIABILITY INSURANCE:** Construction Manager agrees that it will, at its expense, maintain a policy of insurance, written by responsible insurance carriers, approved by Owner that will insure Construction Manager against liability for injury to or death of persons or damage to property occurring about the Premises. Owner will be named as an additional insured. The liability limit must be at least \$2 million for any one person injured or killed or any one occurrence, \$5 million general aggregate coverage for any one accident, and \$2 million property damage. Construction Manager will obtain an endorsement and Certificate of Insurance naming the Owner as an additional insured from Construction Manager's carrier (during the term of the Lease, including Premises Improvement construction) and all contractors during the construction of the Premises Improvements and any other renovation or construction at the Premises. Construction Manager must provide copies of the insurance policy and all endorsements to Owner. Construction Manager shall send the policy to the Law Department. Construction Manager acknowledges and agrees it is responsible for complying with this requirement and will take whatever steps are necessary to ensure its insurer(s) cooperate with Construction Manager in providing all necessary policies and endorsements to Landlord.

**§8.3 CONSTRUCTION MANAGER MUST OBTAIN WORKER'S COMPENSATION INSURANCE:** Construction Manager must maintain employees' Worker's Compensation insurance required under Illinois law, the liability limit must be at least \$2 million

**§8.4 CONSTRUCTION MANAGER MUST OBTAIN BUILDERS RISK INSURANCE FOR PROJECT IMPROVEMENTS:** Construction Manager must maintain builders risk insurance required under Illinois law, the liability limit must be at least \$5 million

**§8.5 CONSTRUCTION MANAGER'S WAIVER OF CASUALTY INSURANCE PROCEEDS:** If the Premises are damaged by fire or other casualty insured against, Construction Manager agrees to claim no interest in any insurance settlement arising out of any loss where premiums are paid by Owner, or where Owner is named as sole beneficiary, and that it will sign all documents required by Owner or the insurance company necessary in connection with the settlement of any loss.

**§8.6 CONTROL OF INSURANCE PROCEEDS TO AVOID TAXABLE GAIN:** If the Premises, including any improvements, were to be damaged in any manner, and the receipt of any insurance proceeds or other reimbursement for such damage would result in the realization of taxable gain for federal or state purposes, then the party to whom the gain would be taxed will have the right to take all action respecting proceeds or reimbursements necessary to enable party to comply with any regulations of the appropriate taxing authorities, so that the gain will not be recognized for tax purposes. **Nothing here will be construed to entitle Owner to delay any repairs to any part of the improvements in the event of damage.**

**§8.7 CONSTRUCTION MANAGER'S FAILURE TO INSURE:** If Construction Manager fails to keep in effect and pay for insurance as required by this section and then fail to cure such failure within five (5) calendar days after notice from Owner, Construction Manager is considered in default..

The Construction Manager shall, within ten (10) calendar days after acceptance of the bid by the City, furnish a performance bond for 110% of the full amount of the contract from insurance companies having not less than A Policyholders Rating from the most recent Alfred M. Best and Co., Inc. listing available. Certification of the insurance company's rating shall be provided prior to contract implementation and quarterly thereafter until contract completion. Should such rating fall below the required A level during performance of the contract, it will be the contractor's responsibility to notify the City and provide a new bond from an insurance company whose rating meets the City's requirements.

*(Table deleted)*

#### **ARTICLE 9 DISPUTE RESOLUTION**

§ 9.1 Any Claim between the Owner and Construction Manager shall be resolved in accordance with the provisions set forth in this Article 9 and Article 15 of A201-2007.

§ 9.2 For any Claim subject to, but not resolved by mediation pursuant to Section 15.3 of AIA Document A201-2007, the method of binding dispute resolution shall be as follows:

*(Check the appropriate box. If the Owner and Construction Manager do not select a method of binding dispute resolution below, or do not subsequently agree in writing to a binding dispute resolution method other than litigation, Claims will be resolved by litigation in a court of competent jurisdiction.)*

Arbitration pursuant to Section 15.4 of AIA Document A201-2007

Litigation in a court of competent jurisdiction

Other: *(Specify)*

*(Paragraphs deleted)*

#### **ARTICLE 10 TERMINATION OR SUSPENSION**

§ 10.1 Termination Prior to Establishment of the Guaranteed Maximum Price

§ 10.1.1 Prior to the execution of the Guaranteed Maximum Price Amendment, the Owner may terminate this Agreement upon not less than seven days' written notice to the Construction Manager for the Owner's convenience and without cause, and the Construction Manager may terminate this Agreement, upon not less than seven days' written notice to the Owner, for the reasons set forth in Section 14.1.1 of A201-2007.

§ 10.1.2 In the event of termination of this Agreement pursuant to Section 10.1.1, the Construction Manager shall be equitably compensated for Preconstruction Phase services performed prior to receipt of a notice of termination. In no event shall the Construction Manager's compensation under this Section exceed the compensation set forth in Section 4.1.

§ 10.1.3 If the Owner terminates the Contract pursuant to Section 10.1.1 after the commencement of the Construction Phase but prior to the execution of the Guaranteed Maximum Price Amendment, the Owner shall pay to the Construction Manager an amount calculated as follows, which amount shall be in addition to any compensation paid to the Construction Manager under Section 10.1.2:

- .1 Take the Cost of the Work incurred by the Construction Manager to the date of termination;
- .2 Add the Construction Manager's Fee computed upon the Cost of the Work to the date of termination at the rate stated in Section 5.1 or, if the Construction Manager's Fee is stated as a fixed sum in that Section, an amount that bears the same ratio to that fixed-sum Fee as the Cost of the Work at the time of termination bears to a reasonable estimate of the probable Cost of the Work upon its completion; and

.3 Subtract the aggregate of previous payments made by the Owner for Construction Phase services.

The Owner shall also pay the Construction Manager fair compensation, either by purchase or rental at the election of the Owner, for any equipment owned by the Construction Manager which the Owner elects to retain and which is not otherwise included in the Cost of the Work under Section 10.1.3.1. To the extent that the Owner elects to take legal assignment of subcontracts and purchase orders (including rental agreements), the Construction Manager shall, as a condition of receiving the payments referred to in this Article 10, execute and deliver all such papers and take all such steps, including the legal assignment of such subcontracts and other contractual rights of the Construction Manager, as the Owner may require for the purpose of fully vesting in the Owner the rights and benefits of the Construction Manager under such subcontracts or purchase orders. All Subcontracts, purchase orders and rental agreements entered into by the Construction Manager will contain provisions allowing for assignment to the Owner as described above.

If the Owner accepts assignment of subcontracts, purchase orders or rental agreements as described above, the Owner will reimburse or indemnify the Construction Manager for all costs arising under the subcontract, purchase order or rental agreement, if those costs would have been reimbursable as Cost of the Work if the contract had not been terminated. If the Owner chooses not to accept assignment of any subcontract, purchase order or rental agreement that would have constituted a Cost of the Work had this agreement not been terminated, the Construction Manager will terminate the subcontract, purchase order or rental agreement and the Owner will pay the Construction Manager the costs necessarily incurred by the Construction Manager because of such termination.

#### **§ 10.2 Termination Subsequent to Establishing Guaranteed Maximum Price**

Following execution of the Guaranteed Maximum Price Amendment and subject to the provisions of Section 10.2.1 and 10.2.2 below, the Contract may be terminated as provided in Article 14 of AIA Document A201–2007.

**§ 10.2.1** If the Owner terminates the Contract after execution of the Guaranteed Maximum Price Amendment, the amount payable to the Construction Manager pursuant to Sections 14.2 and 14.4 of A201–2007 shall not exceed the amount the Construction Manager would otherwise have received pursuant to Sections 10.1.2 and 10.1.3 of this Agreement.

**§ 10.2.2** If the Construction Manager terminates the Contract after execution of the Guaranteed Maximum Price Amendment, the amount payable to the Construction Manager under Section 14.1.3 of A201–2007 shall not exceed the amount the Construction Manager would otherwise have received under Sections 10.1.2 and 10.1.3 above, except that the Construction Manager's Fee shall be calculated as if the Work had been fully completed by the Construction Manager, utilizing as necessary a reasonable estimate of the Cost of the Work for Work not actually completed.

#### **§ 10.3 Suspension**

The Work may be suspended by the Owner as provided in Article 14 of AIA Document A201–2007. In such case, the Guaranteed Maximum Price and Contract Time shall be increased as provided in Section 14.3.2 of AIA Document A201–2007, except that the term "profit" shall be understood to mean the Construction Manager's Fee as described in Sections 5.1 and 5.3.5 of this Agreement.

### **ARTICLE 11 MISCELLANEOUS PROVISIONS**

**§ 11.1** Terms in this Agreement shall have the same meaning as those in A201–2007.

#### **§ 11.2 Ownership and Use of Documents**

Section 1.5 of A201–2007 shall apply to both the Preconstruction and Construction Phases.

#### **§ 11.3 Governing Law**

Section 13.1 of A201–2007 shall apply to both the Preconstruction and Construction Phases.

#### **§ 11.4 Assignment**

The Owner and Construction Manager, respectively, bind themselves, their agents, successors, assigns and legal representatives to this Agreement. Neither the Owner nor the Construction Manager shall assign this Agreement without the written consent of the other, except that the Owner may assign this Agreement to a lender providing financing for the Project if the lender agrees to assume the Owner's rights and obligations under this Agreement. Except as provided in Section 13.2.2 of A201–2007, neither party to the Contract shall assign the Contract as a whole

Init.

without written consent of the other. If either party attempts to make such an assignment without such consent, that party shall nevertheless remain legally responsible for all obligations under the Contract.

§ 11.5 Other provisions:

None

ARTICLE 12 SCOPE OF THE AGREEMENT

§ 12.1 This Agreement represents the entire and integrated agreement between the Owner and the Construction Manager and supersedes all prior negotiations, representations or agreements, either written or oral. This Agreement may be amended only by written instrument signed by both Owner and Construction Manager.

§ 12.2 The following documents comprise the Agreement:

- .1 AIA Document A133-2009, Standard Form of Agreement Between Owner and Construction Manager as Constructor where the basis of payment is the Cost of the Work Plus a Fee with a Guaranteed Maximum Price
- .2 AIA Document A201-2007, General Conditions of the Contract for Construction

(Paragraphs deleted)

- .5 Other documents:  
(List other documents, if any, forming part of the Agreement.)

City of Evanston RFP 17-57 dated October 5, 2017  
 City of Evanston RFP 17-57, addendum #1 dated October 16, 2017  
 City of Evanston RFP 17-57, addendum #2 dated October 24, 2017  
 Bulley and Andrews Proposal dated November 7, 2017  
 Bulley and Andrews post interview response dated December 29, 2017  
 City of Evanston Contractor Services Agreement AIA-133-2009  
 AIA -A201-2017

This Agreement is entered into as of the day and year first written above.

  
 OWNER (Signature)

Wally Bobkiewicz, City Manager  
 (Printed name and title)

  
 CONSTRUCTION MANAGER (Signature)

Tim Puntillo, Executive Vice President  
 (Printed name and title)

Approved as to form:  
  
 W. Grant Farrar  
 Corporation Counsel

Init.

# **Additions and Deletions Report for AIA® Document A133™ – 2009**

This Additions and Deletions Report, as defined on page 1 of the associated document, reproduces below all text the author has added to the standard form AIA document in order to complete it, as well as any text the author may have added to or deleted from the original AIA text. Added text is shown underlined. Deleted text is indicated with a horizontal line through the original AIA text.

Note: This Additions and Deletions Report is provided for information purposes only and is not incorporated into or constitute any part of the associated AIA document. This Additions and Deletions Report and its associated document were generated simultaneously by AIA software at 10:00:39 on 02/26/2018.

## **PAGE 1**

City of Evanston  
2100 Ridge Avenue  
Evanston, Illinois 60201

...

Bulley & Andrews  
1755 W. Armitage Avenue  
Chicago, Illinois 60622

...

Robert Crown Community Center, Ice Complex, and Library  
1801 Main Street Evanston, Illinois 60202

...

Woodhouse Tinucci Architects  
230 W Superior Street 6FL  
Chicago, IL 60654

...

Erika Storlie  
City of Evanston  
2100 Ridge Avenue  
Evanston, Illinois 60201  
847-448-8007estorlie@cityofevanston.org

...

Tim Puntillo  
Bulley & Andrews  
1755 W. Armitage Avenue  
Chicago, Illinois 60622  
773-645-5813  
tpuntillo@bulley.com  
**PAGE 2**

David Woodhouse

...

Additions and Deletions Report for AIA Document A133™ – 2009 (formerly A121™CMc – 2003). Copyright © 1991, 2003 and 2009 by The American Institute of Architects. All rights reserved. **WARNING: This AIA® Document is protected by U.S. Copyright Law and International Treaties. Unauthorized reproduction or distribution of this AIA® Document, or any portion of it, may result in severe civil and criminal penalties, and will be prosecuted to the maximum extent possible under the law.** This document was produced by AIA software at 10:00:39 on 02/26/2018 under Order No.2737583500 which expires on 10/24/2018, and is not for resale.  
**User Notes:**

(1815103787)

Telephone Number: 312-943-3120  
Fax Number: 312-943-3432  
Mobile Number: 773-562-7278  
Email Address: d.woodhouse@woodtinarch.com  
**PAGE 5**

§ 2.2.4 In preparing the Construction Manager's Guaranteed Maximum Price proposal, the Construction Manager shall include its contingency for the Construction Manager's exclusive use to cover those costs considered reimbursable as the Cost of the Work but not included in a Change Order. The Guaranteed Maximum Price includes a 8% Design/Budget contingency to be controlled by the Owner. The intent of this contingency is to allow for design development and completion to occur without needing to go outside the value of the contracted early GMP. After completion of all bid packages and subcontractor awards, 100% of the remaining Design/Build contingency funds will be returned to the Owner via a change order to the Guaranteed Maximum Price and held as an Owner's contingency.

§ 2.2.5 The Construction Manager shall meet with the Owner and Architect to review the Guaranteed Maximum Price proposal. In the event that the Owner and Architect discover any inconsistencies or inaccuracies in the information presented, they shall promptly notify the Construction Manager, who shall make appropriate adjustments to the Guaranteed Maximum Price proposal, its basis, or both.

§ 2.2.5 Construction Contingency. The Guaranteed Maximum Price also includes a 2% Construction Contingency, to be controlled by the Construction Manager with notification to the Owner, from the start of the project until completion if funds are drawn. 100% of the remaining Construction Contingency will be returned to the Owner at the completion of the Project.

.1 In preparing the Construction Manager's Guaranteed Maximum Price proposal, the Construction Manager will include its contingency of Two Percent (2%) of the estimated Cost of the Work for the Construction Manager's exclusive use to cover those costs considered reimbursable as the Cost of the Work but not included in a Change Order. This contingency cannot be used to reimburse lump sum general conditions coverage costs.

.2 The Construction Manager's Contingency is not allocated to any particular item of Cost of Work, may be utilized without the necessity of any Change Order, and shall be used to mitigate risk and unanticipated costs that may occur between Construction Manager's and its Subcontractor's incurred from portions of Work inadvertently not assigned to any Subcontractor, items that were not anticipated by Construction Manager at the time of Owner's approval of the Guaranteed Maximum Price Proposal, Subcontractor defaults, Construction Manager's insurance deductibles, coordination of the work of Subcontractors with Owner's Separate Contractors, corrections in the Work provided Construction Manager has exhausted all reasonable means short of arbitration to obtain correction from any responsible Subcontractors, and costs required to maintain the Project Schedule (not due to the Owner's or Architects actions or failure to act other excusable delays as defined by Section 8.3.1 of the General Conditions ("Excusable Delays")).

.3 The Construction Manager's Contingency cannot be used to offset or fund Owner-ordered changes in the Work, design errors, omissions, incompleteness or lack of design coordination, changes in scope, systems, kinds and quality of materials, finishes or equipment, costs caused by Excusable Delays, costs of addressing differing or concealed conditions, costs of Handling Hazardous Substances not brought to site by Construction Manager, costs of industry-wide shortages or industry-wide price escalations or any other costs or damages for which Construction Manager is entitled to an increase in the Guaranteed Maximum Price.

.4 Whenever any of the Contract Documents use the terms or phrases "at Contractor's (or Construction Manager's) sole expense", "at no cost to Owner", "Contractor shall pay to Owner", "Owner may deduct", "a Change Order deducting", "Contractor shall bear", "to be borne by Contractor" or the like, such terms or phrases shall be deemed modified by the following "subject to Construction Manager's right to use Construction Manager's Contingency, pursuant to the terms and conditions of Section 2.2.5 of the Agreement."

.5 Construction Manager shall maintain a "Construction Manager's Contingency Expense Log" which shall contain a list and description of all items paid out of the Construction Manager's Contingency and showing movement from the Construction Manager's Contingency to other line items. Construction Manager shall update and submit a copy of such Construction Manager's Contingency Expense Log and supporting documentation reasonably acceptable to Owner along with each application for payment and at any other time when reasonably requested by Owner."

§ 2.2.6 If the Owner notifies the Construction Manager that the Owner has accepted the Guaranteed Maximum Price proposal in writing before the date specified in the Guaranteed Maximum Price proposal, the Guaranteed Maximum Price proposal shall be deemed effective without further acceptance from the Construction Manager. Following acceptance of a Guaranteed Maximum Price, the Owner and Construction Manager shall execute the Guaranteed Maximum Price Amendment amending this Agreement, a copy of which the Owner shall provide to the Architect. The Guaranteed Maximum Price Amendment shall set forth the agreed upon Guaranteed Maximum Price with the information and assumptions upon which it is based. The Construction Manager shall meet with the Owner and Architect to review the Guaranteed Maximum Price proposal. In the event that the Owner and Architect discover any inconsistencies or inaccuracies in the information presented, they shall promptly notify the Construction Manager, who shall make appropriate adjustments to the Guaranteed Maximum Price proposal, its basis, or both.

§ 2.2.7 The Construction Manager shall not incur any cost to be reimbursed as part of the Cost of the Work prior to the commencement of the Construction Phase, unless the Owner provides prior written authorization for such costs. If the Owner notifies the Construction Manager that the Owner has accepted the Guaranteed Maximum Price proposal in writing before the date specified in the Guaranteed Maximum Price proposal, the Guaranteed Maximum Price proposal shall be deemed effective without further acceptance from the Construction Manager. Following acceptance of a Guaranteed Maximum Price, the Owner and Construction Manager shall execute the Guaranteed Maximum Price Amendment amending this Agreement, a copy of which the Owner shall provide to the Architect. The Guaranteed Maximum Price Amendment shall set forth the agreed upon Guaranteed Maximum Price with the information and assumptions upon which it is based.

§ 2.2.8 The Owner shall authorize the Architect to provide the revisions to the Drawings and Specifications to incorporate the agreed upon assumptions and clarifications contained in the Guaranteed Maximum Price Amendment. The Owner shall promptly furnish those revised Drawings and Specifications to the Construction Manager as they are revised. The Construction Manager shall notify the Owner and Architect of any inconsistencies between the Guaranteed Maximum Price Amendment and the revised Drawings and Specifications. Construction Manager shall not incur any cost to be reimbursed as part of the Cost of the Work prior to the commencement of the Construction Phase, unless the Owner provides prior written authorization for such costs.

§ 2.2.9 The Construction Manager shall include in the Guaranteed Maximum Price all sales, consumer, use and similar taxes for the Work provided by the Construction Manager that are legally enacted, whether or not yet effective, at the time the Guaranteed Maximum Price Amendment is executed. Owner shall authorize the Architect to provide the revisions to the Drawings and Specifications to incorporate the agreed upon assumptions and clarifications contained in the Guaranteed Maximum Price Amendment. The Owner shall promptly furnish those revised Drawings and Specifications to the Construction Manager as they are revised. The Construction Manager shall notify the Owner and Architect of any inconsistencies between the Guaranteed Maximum Price Amendment and the revised Drawings and Specifications.

§ 2.2.10 The Construction Manager shall include in the Guaranteed Maximum Price all sales, consumer, use and similar taxes for the Work provided by the Construction Manager that are legally enacted, whether or not yet effective, at the time the Guaranteed Maximum Price Amendment is executed. The City of Evanston is tax exempt and Construction Manager must submit sales tax exemption information prior to purchases to prevent sales tax from being assessed in the subject transaction.

PAGE 9

§ 4.2.2 Payments are due and payable upon presentation of the Construction Manager's invoice. Amounts unpaid ( ) days after the invoice date shall bear interest at the rate entered below, or in the absence thereof at the legal rate prevailing from time to time at the principal place of business of the Construction Manager. (Insert rate of monthly or annual interest agreed upon.)

—%

invoice and in accordance with the Illinois Local Government Prompt Payment Act, 50 ILCS 505/et seq. Any bill approved for payment pursuant to Section 3 shall be paid within 30 days after the date of approval.

PAGE 10

Task 1 (preconstruction services): \$41,510.00 not to exceed.

Task 2 (construction services): 1.75% times the Cost of the Work.

Additions and Deletions Report for AIA Document A133™ – 2009 (formerly A121™CMc – 2003). Copyright © 1991, 2003 and 2009 by The American Institute of Architects. All rights reserved. **WARNING: This AIA® Document is protected by U.S. Copyright Law and International Treaties. Unauthorized reproduction or distribution of this AIA® Document, or any portion of it, may result in severe civil and criminal penalties, and will be prosecuted to the maximum extent possible under the law.** This document was produced by AIA software at 10:00 39 on 02/26/2018 under Order No 2737583500 which expires on 10/24/2018, and is not for resale.

User Notes:

(1815103787)



...

For changes in work that result in a net additive cost but no schedule impact, construction manager's fee of 3% times the cost of the work will be included. For changes in the work that result in a change of the project completion date, general conditions cost will be included as a cost of the change work.

There shall be no credit of Construction Manager's Fee on changes in work that result in a net credit.

In addition to the CM Fee markup, the following markups will be included on changes in the work...

- General Liability Insurance – 1% times the cost of the work
- Subcontractor Default Insurance – 1.1% times the cost of subcontractor work
- Payment and Performance Bond – 0.525% times the cost of the work
- General Conditions – no additional markup beyond CM fee markup for changes that do not impact project schedule. For changes that modify project schedule, general conditions will be included as actual cost of the work.

...

Subcontractor markup on increases in the cost of its portion of work limited to 5% overhead and 5% profit.

§ 5.1.4 Rental rates for Construction Manager-owned equipment shall not exceed percent (—%) of the standard rate paid at the place of the Project ninety percent ( 90%) of the AED Green Book.

...

To be included with GMP amendment

...

*(Insert specific provisions if the Construction Manager is to participate in any savings.)*

**PAGE 12**

§ 6.6.2 Sales, use or similar taxes imposed by a governmental authority that are related to the Work and for which the Construction Manager is liable. The City of Evanston is tax exempt and construction manager will submit sales tax exemption information prior to purchases to prevent sales tax from being assessed in the subject transaction. Federal Excise Tax does not apply to materials purchased by the City of Evanston by virtue of Exemption Certificate No. A-208762, Illinois Retailers' Occupation Tax, Use Tax, and Municipal Retailers' Occupation Tax do not apply to materials or services purchased by the City of Evanston by virtue of Statute. The City of Evanston is exempt from Illinois Sales Tax by virtue of Exemption Identification number E9998-1750-07. The City's federal tax ID number is 36-6005870.

§ 6.6.3 Fees and assessments for the building permit and for other permits, licenses and inspections for which the Construction Manager is required by the Contract Documents to pay. All fees typically assessed by the City of Evanston for the construction of this project will be waived. This waiver does not apply to any other government agencies and Construction Manager must pay the applicable fees assessed.

**PAGE 14**

§ 7.1.3 Provided that an Application for Payment is received by the Architect not later than the — day of a month, the Owner shall make payment of the certified amount to the Construction Manager not later than the — day of the month. If an Application for Payment is received by the Architect after the application date fixed above, payment shall be made by the Owner not later than — ( — ) days after the Architect receives the Application for Payment. (Federal, state or local laws may require payment within a certain period of time.)

- ~~.1~~ The City will withhold 10% retention on all progress payments. This 10% retention includes: construction manager's fee, general conditions, general requirements, construction manager's self-performed work, all subcontractor work and all supplier materials. The City will review each request for progress payments after it receives partial lien waivers for the requested progress payment. The City will disburse the remaining 10% on all progress payments only after punch list work is complete, final lien waivers, certified payroll, warranties, and other close out documents are reviewed and approved by the City. Neither the final payment nor any part of any retained percentages, shall become due until the contractor, delivers to the City, a complete release of all liens arising out of this contract, or receipts in full in lieu thereof and, if required in either case, an affidavit that so far as it has knowledge or information the releases and receipts include all the labor and material for which a lien could be filed. If any lien remains unsatisfied after all payments are made the contractor shall refund to the City all moneys that the latter may be compelled to pay in discharging such a lien, including all costs and attorney's fees. Construction manager shall also submit trailing lien waivers as a condition of approval of each pay application.
- ~~.2~~ Prior to final payment, contractor shall fully restore all property disturbed or damaged during the course of this work. This includes, but is not limited to public property, (walks, curbs, roadways, trees, etc.) private property, and utilities. This shall also include removal of temporary facilities erected during the course of this contract and restoration of these areas. All restoration work shall be subject to the approval of the City and shall restore the property to a condition at least equal to that existing prior to the start of this contract. All restoration work of property damaged by contractor shall be accomplished at the sole expense of the contractor.
- ~~.3~~ The payments are computed by taking that portion of the Guaranteed Maximum Price properly allocable to completed Work as determined by multiplying the percentage of completion of each portion of the Work by the share of the Guaranteed Maximum Price allocated to that portion of the Work in the schedule of values. Pending final determination of cost to the Owner of changes in the Work, amounts not in dispute shall be included as provided in Section 7.3.9 of AIA Document A201-2007;
- ~~.2~~ .4 Add that portion of the Guaranteed Maximum Price properly allocable to materials and equipment delivered and suitably stored at the site for subsequent incorporation in the Work, or if approved in advance by the Owner, suitably stored off the site at a location agreed upon in writing;
- ~~.3~~ .5 Add the Construction Manager's Fee, less retainage of percent (~~ten percent (10 %)~~). The Construction Manager's Fee shall be computed upon the Cost of the Work at the rate stated in Section 5.1 or, if the Construction Manager's Fee is stated as a fixed sum in that Section, shall be an amount that bears the same ratio to that fixed-sum fee as the Cost of the Work bears to a reasonable estimate of the probable Cost of the Work upon its completion;
- ~~.4~~ .6 Subtract retainage of percent (~~ten percent (10 %)~~) from that portion of the Work that the Construction Manager self-performs;
- ~~.5~~ .7 Subtract the aggregate of previous payments made by the Owner;
- ~~.6~~ .8 Subtract the shortfall, if any, indicated by the Construction Manager in the documentation required by Section 7.1.4 to substantiate prior Applications for Payment, or resulting from errors subsequently discovered by the Owner's auditors in such documentation; and
- ~~.7~~ .10 Subtract amounts, if any, for which the Architect has withheld or nullified a Certificate for Payment as provided in Section 9.5 of AIA Document A201-2007.

§ 7.2.1 Final payment, constituting the entire unpaid balance of the Contract Sum, shall be made by the Owner to the Construction Manager ~~when~~

- ~~.1~~ the Construction Manager has fully performed the Contract except for the Construction Manager's responsibility to correct Work as provided in Section 12.2.2 of AIA Document A201-2007, and to satisfy other requirements, if any, which extend beyond final payment;

- ~~2 — the Construction Manager has submitted a final accounting for the Cost of the Work and a final Application for Payment; and~~
- ~~3 — a final Certificate for Payment has been issued by the Architect.~~

~~The Owner's final payment to the Construction Manager shall be made no later than 30 days after the issuance of the Architect's final Certificate for Payment, or as follows:~~

~~in accordance with the statutory requirements of the Illinois Prompt Payment Act and pursuant to the contract schedule established by the parties.~~

PAGE 17

~~(State bonding requirements, if any, and limits of liability for insurance required in Article 11 of AIA Document A201-2007.)~~

**§8.1 INSURANCE COMPANIES:** It is agreed that any policies of insurance to be maintained by Construction Manager will be obtained from good and solvent insurance companies. Only companies with an "A" Policyholder's Rating with the Alfred Best Company will be acceptable to Landlord.

**§8.2 CONSTRUCTION MANAGER MUST OBTAIN GENERAL LIABILITY INSURANCE:** Construction Manager agrees that it will, at its expense, maintain a policy of insurance, written by responsible insurance carriers, approved by Owner that will insure Construction Manager against liability for injury to or death of persons or damage to property occurring about the Premises. Owner will be named as an additional insured. The liability limit must be at least \$2 million for any one person injured or killed or any one occurrence, \$5 million general aggregate coverage for any one accident, and \$2 million property damage. Construction Manager will obtain an endorsement and Certificate of Insurance naming the Owner as an additional insured from Construction Manager's carrier (during the term of the Lease, including Premises Improvement construction) and all contractors during the construction of the Premises Improvements and any other renovation or construction at the Premises. Construction Manager must provide copies of the insurance policy and all endorsements to Owner. Construction Manager shall send the policy to the Law Department. Construction Manager acknowledges and agrees it is responsible for complying with this requirement and will take whatever steps are necessary to ensure its insurer(s) cooperate with Construction Manager in providing all necessary policies and endorsements to Landlord.

**§8.3 CONSTRUCTION MANAGER MUST OBTAIN WORKER'S COMPENSATION INSURANCE:** Construction Manager must maintain employees' Worker's Compensation insurance required under Illinois law, the liability limit must be at least \$2 million

**§8.4 CONSTRUCTION MANAGER MUST OBTAIN BUILDERS RISK INSURANCE FOR PROJECT IMPROVEMENTS:** Construction Manager must maintain builders risk insurance required under Illinois law, the liability limit must be at least \$5 million

**§8.5 CONSTRUCTION MANAGER'S WAIVER OF CASUALTY INSURANCE PROCEEDS:** If the Premises are damaged by fire or other casualty insured against, Construction Manager agrees to claim no interest in any insurance settlement arising out of any loss where premiums are paid by Owner, or where Owner is named as sole beneficiary, and that it will sign all documents required by Owner or the insurance company necessary in connection with the settlement of any loss.

**§8.6 CONTROL OF INSURANCE PROCEEDS TO AVOID TAXABLE GAIN:** If the Premises, including any improvements, were to be damaged in any manner, and the receipt of any insurance proceeds or other reimbursement for such damage would result in the realization of taxable gain for federal or state purposes, then the party to whom the gain would be taxed will have the right to take all action respecting proceeds or reimbursements necessary to enable party to comply with any regulations of the appropriate taxing authorities, so that the gain will not be recognized for tax purposes. **Nothing here will be construed to entitle Owner to delay any repairs to any part of the improvements in the event of damage.**

**§8.7 CONSTRUCTION MANAGER'S FAILURE TO INSURE:** If Construction Manager fails to keep in effect and pay for insurance as required by this section and then fail to cure such failure within five (5) calendar days after notice from Owner, Construction Manager is considered in default.

Additions and Deletions Report for AIA Document A133™ – 2009 (formerly A121™CMc – 2003). Copyright © 1991, 2003 and 2009 by The American Institute of Architects. All rights reserved. **WARNING: This AIA® Document is protected by U.S. Copyright Law and International Treaties. Unauthorized reproduction or distribution of this AIA® Document, or any portion of it, may result in severe civil and criminal penalties, and will be prosecuted to the maximum extent possible under the law.** This document was produced by AIA software at 10:00:39 on 02/26/2018 under Order No. 2737583500 which expires on 10/24/2018, and is not for resale.

User Notes:

(1815103787)

The Construction Manager shall, within ten (10) calendar days after acceptance of the bid by the City, furnish a performance bond for 110% of the full amount of the contract from insurance companies having not less than A Policyholders Rating from the most recent Alfred M. Best and Co., Inc. listing available. Certification of the insurance company's rating shall be provided prior to contract implementation and quarterly thereafter until contract completion. Should such rating fall below the required A level during performance of the contract, it will be the contractor's responsibility to notify the City and provide a new bond from an insurance company whose rating meets the City's requirements.

**Type of Insurance or Bond**

**Limit of Liability or Bond Amount (\$0.00)**

PAGE 18

~~§ 9.1 Any Claim between the Owner and Construction Manager shall be resolved in accordance with the provisions set forth in this Article 9 and Article 15 of A201-2007. However, for Claims arising from or relating to the Construction Manager's Preconstruction Phase services, no decision by the Initial Decision Maker shall be required as a condition precedent to mediation or binding dispute resolution, and Section 9.3 of this Agreement shall not apply.~~

...

[ X ] Litigation in a court of competent jurisdiction

...

**~~§ 9.3 Initial Decision Maker~~**

~~The Architect will serve as the Initial Decision Maker pursuant to Section 15.2 of AIA Document A201-2007 for Claims arising from or relating to the Construction Manager's Construction Phase services, unless the parties appoint below another individual, not a party to the Agreement, to serve as the Initial Decision Maker.  
(If the parties mutually agree, insert the name, address and other contact information of the Initial Decision Maker, if other than the Architect.)~~

PAGE 20

None

...

~~3 AIA Document E201™ 2007, Digital Data Protocol Exhibit, if completed, or the following:~~

~~4 AIA Document E202™ 2008, Building Information Modeling Protocol Exhibit, if completed, or the following:~~

*(List other documents, if any, forming part of the Agreement.)*

City of Evanston RFP 17-57 dated October 5, 2017  
City of Evanston RFP 17-57, addendum #1 dated October 16, 2017  
City of Evanston RFP 17-57, addendum #2 dated October 24, 2017  
Bulley and Andrews Proposal dated November 7, 2017  
Bulley and Andrews post interview response dated December 29, 2017  
City of Evanston Contractor Services Agreement AIA-133-2009  
AIA -A201-2017

...

Wally Bobkiewicz, City Manager

Tim Puntillo, Executive Vice President

## **Certification of Document's Authenticity**

**AIA® Document D401™ – 2003**

I, \_\_\_\_\_, hereby certify, to the best of my knowledge, information and belief, that I created the attached final document simultaneously with its associated Additions and Deletions Report and this certification at 10:00:39 on 02/26/2018 under Order No. 2737583500 from AIA Contract Documents software and that in preparing the attached final document I made no changes to the original text of AIA® Document A133™ – 2009, Standard Form of Agreement Between Owner and Construction Manager as Constructor where the basis of payment is the Cost of the Work Plus a Fee with a Guaranteed Maximum Price, as published by the AIA in its software, other than those additions and deletions shown in the associated Additions and Deletions Report.

\_\_\_\_\_  
*(Signed)*

\_\_\_\_\_  
*(Title)*

\_\_\_\_\_  
*(Dated)*



# AIA® Document A201™ – 2007

## General Conditions of the Contract for Construction

**for the following PROJECT:**

*(Name and location or address)*

Robert Crown Community Center, Ice Complex, and Library  
1801 Main Street Evanston, Illinois, 60202

**THE OWNER:**

*(Name, legal status and address)*

City of Evanston  
2100 Ridge Avenue  
Evanston, Illinois 60201

**THE ARCHITECT:**

*(Name, legal status and address)*

Woodhouse Tinucci Architects  
230 W Superior Street 6FL  
Chicago, IL 60654

**TABLE OF ARTICLES**

- 1 GENERAL PROVISIONS
- 2 OWNER
- 3 CONTRACTOR
- 4 ARCHITECT
- 5 SUBCONTRACTORS
- 6 CONSTRUCTION BY OWNER OR BY SEPARATE CONTRACTORS
- 7 CHANGES IN THE WORK
- 8 TIME
- 9 PAYMENTS AND COMPLETION
- 10 PROTECTION OF PERSONS AND PROPERTY
- 11 INSURANCE AND BONDS
- 12 UNCOVERING AND CORRECTION OF WORK
- 13 MISCELLANEOUS PROVISIONS
- 14 TERMINATION OR SUSPENSION OF THE CONTRACT
- 15 CLAIMS AND DISPUTES

**ADDITIONS AND DELETIONS:**

The author of this document has added information needed for its completion. The author may also have revised the text of the original AIA standard form. An *Additions and Deletions Report* that notes added information as well as revisions to the standard form text is available from the author and should be reviewed. A vertical line in the left margin of this document indicates where the author has added necessary information and where the author has added to or deleted from the original AIA text.

This document has important legal consequences. Consultation with an attorney is encouraged with respect to its completion or modification.

Init.

AIA Document A201™ – 2007. Copyright © 1911, 1915, 1918, 1925, 1937, 1951, 1958, 1961, 1963, 1966, 1970, 1976, 1987, 1997 and 2007 by The American Institute of Architects. All rights reserved. **WARNING: This AIA® Document is protected by U.S. Copyright Law and International Treaties. Unauthorized reproduction or distribution of this AIA® Document, or any portion of it, may result in severe civil and criminal penalties, and will be prosecuted to the maximum extent possible under the law.** This document was produced by AIA software at 10:01:17 on 02/26/2018 under Order No.2737583500 which expires on 10/24/2018, and is not for resale.

User Notes:

(1953391157)

## INDEX

(Topics and numbers in bold are section headings.)

### Acceptance of Nonconforming Work

9.6.6, 9.9.3, **12.3**

### Acceptance of Work

9.6.6, 9.8.2, 9.9.3, 9.10.1, 9.10.3, **12.3**

### Access to Work

**3.16**, 6.2.1, 12.1

### Accident Prevention

**10**

### Acts and Omissions

3.2, 3.3.2, 3.12.8, 3.18, 4.2.3, 8.3.1, 9.5.1, 10.2.5, 10.2.8, 13.4.2, 13.7, 14.1, 15.2

### Addenda

1.1.1, 3.11

### Additional Costs, Claims for

3.7.4, 3.7.5, 6.1.1, 7.3.7.5, 10.3, 15.1.4

### Additional Inspections and Testing

9.4.2, 9.8.3, 12.2.1, **13.5**

### Additional Insured

11.1.4

### Additional Time, Claims for

3.2.4, 3.7.4, 3.7.5, 3.10.2, 8.3.2, **15.1.5**

### Administration of the Contract

3.1.3, **4.2**, 9.4, 9.5

### Advertisement or Invitation to Bid

1.1.1

### Aesthetic Effect

4.2.13

### Allowances

**3.8**, 7.3.8

### All-risk Insurance

11.3.1, 11.3.1.1

### Applications for Payment

4.2.5, 7.3.9, 9.2, **9.3**, 9.4, 9.5.1, 9.6.3, 9.7, 9.10, 11.1.3

### Approvals

2.1.1, 2.2.2, 2.4, 3.1.3, 3.10.2, 3.12.8, 3.12.9, 3.12.10, 4.2.7, 9.3.2, 13.5.1

### Arbitration

8.3.1, , 13.1

## ARCHITECT

**4**

### Architect, Definition of

**4.1.1**

### Architect, Extent of Authority

2.4, 3.12.7, 4.1, 4.2, 5.2, 6.3, 7.1.2, 7.3.7, 7.4, 9.2, 9.3.1, 9.4, 9.5, 9.6.3, 9.8, 9.10.1, 9.10.3, 12.1, 12.2.1, 13.5.1, 13.5.2, 14.2.2, 14.2.4, 15.1.3,

### Architect, Limitations of Authority and Responsibility

2.1.1, 3.12.4, 3.12.8, 3.12.10, 4.1.2, 4.2.1, 4.2.2, 4.2.3, 4.2.6, 4.2.7, 4.2.10, 4.2.12, 4.2.13, 5.2.1, 7.4, 9.4.2, 9.5.3, 9.6.4, 15.1.3, 15.2

### Architect's Additional Services and Expenses

2.4, 11.3.1.1, 12.2.1, 13.5.2, 13.5.3, 14.2.4

### Architect's Administration of the Contract

3.1.3, 4.2, 3.7.4, 15.2, 9.4.1, 9.5

### Architect's Approvals

2.4, 3.1.3, 3.5, 3.10.2, 4.2.7

### Architect's Authority to Reject Work

3.5, 4.2.6, 12.1.2, 12.2.1

### Architect's Copyright

1.1.7, 1.5

### Architect's Decisions

3.7.4, 4.2.6, 4.2.7, 4.2.11, 4.2.12, 4.2.13, 4.2.14, 6.3, 7.3.7, 7.3.9, 8.1.3, 8.3.1, 9.2, 9.4.1, 9.5, 9.8.4, 9.9.1, 13.5.2, 15.2

### Architect's Inspections

3.7.4, 4.2.2, 4.2.9, 9.4.2, 9.8.3, 9.9.2, 9.10.1, 13.5

### Architect's Instructions

3.2.4, 3.3.1, 4.2.6, 4.2.7, 13.5.2

### Architect's Interpretations

4.2.11, 4.2.12

### Architect's Project Representative

4.2.10

### Architect's Relationship with Contractor

1.1.2, 1.5, 3.1.3, 3.2.2, 3.2.3, 3.2.4, 3.3.1, 3.4.2, 3.5, 3.7.4, 3.7.5, 3.9.2, 3.9.3, 3.10, 3.11, 3.12, 3.16, 3.18, 4.1.2, 4.1.3, 4.2, 5.2, 6.2.2, 7, 8.3.1, 9.2, 9.3, 9.4, 9.5, 9.7, 9.8, 9.9, 10.2.6, 10.3, , 12, 13.4.2, 13.5, 15.2

### Architect's Relationship with Subcontractors

1.1.2, 4.2.3, 4.2.4, 4.2.6, 9.6.3, 9.6.4,

### Architect's Representations

9.4.2, 9.5.1, 9.10.1

### Architect's Site Visits

3.7.4, 4.2.2, 4.2.9, 9.4.2, 9.5.1, 9.9.2, 9.10.1, 13.5

### Asbestos

10.3.1

### Attorneys' Fees

3.18.1, 9.10.2, 10.3.3

### Award of Separate Contracts

6.1.1, 6.1.2

### Award of Subcontracts and Other Contracts for Portions of the Work

**5.2**

### Basic Definitions

**1.1**

### Bidding Requirements

1.1.1, 5.2.1, 11.4.1

### Binding Dispute Resolution

9.7, , , 13.1, ,

### Boiler and Machinery Insurance

**11.3.2**

### Bonds, Lien

7.3.7.4, 9.10.2, 9.10.3

### Bonds, Performance, and Payment

7.3.7.4, 9.6.7, 9.10.3, , **11.4**

### Building Permit

3.7.1

Init.

AIA Document A201™ – 2007. Copyright © 1911, 1915, 1918, 1925, 1937, 1951, 1958, 1961, 1963, 1966, 1970, 1976, 1987, 1997 and 2007 by The American Institute of Architects. All rights reserved. **WARNING: This AIA® Document is protected by U.S. Copyright Law and International Treaties. Unauthorized reproduction or distribution of this AIA® Document, or any portion of it, may result in severe civil and criminal penalties, and will be prosecuted to the maximum extent possible under the law.** This document was produced by AIA software at 10:01:17 on 02/26/2018 under Order No.2737583500 which expires on 10/24/2018, and is not for resale.

User Notes:

(1953391157)



## Capitalization

### 1.3

Certificate of Substantial Completion

9.8.3, 9.8.4, 9.8.5

### Certificates for Payment

4.2.1, 4.2.5, 4.2.9, 9.3.3, 9.4, 9.5, 9.6.1, 9.6.6, 9.7, 9.10.1, 9.10.3, 14.1.1.3, 14.2.4, 15.1.3

Certificates of Inspection, Testing or Approval  
13.5.4

Certificates of Insurance

9.10.2, 11.1.3

### Change Orders

1.1.1, 2.4, 3.4.2, 3.7.4, 3.8.2.3, 3.11, 3.12.8, 4.2.8, 5.2.3, 7.1.2, 7.1.3, 7.2, 7.3.2, 7.3.6, 7.3.9, 7.3.10, 8.3.1, 9.3.1.1, 9.10.3, 10.3.2, 11.3.1.2, 11.3.4, , 12.1.2, 15.1.3

Change Orders, Definition of

7.2.1

## CHANGES IN THE WORK

2.2.1, 3.11, 4.2.8, 7, 7.2.1, 7.3.1, 7.4, 8.3.1, 9.3.1.1,

Claims, Definition of

15.1.1

## CLAIMS AND DISPUTES

3.2.4, 6.1.1, 6.3, 7.3.9, 9.3.3, 9.10.4, 10.3.3, 15

### Claims

*(Paragraphs deleted)*

for Additional Cost

3.2.4, 3.7.4, 6.1.1, 7.3.9, 10.3.2, 15.1.4

Claims for Additional Time

3.2.4, 3.7.4, 6.1.1, 8.3.2, 10.3.2, 15.1.5

Concealed or Unknown Conditions, Claims for  
3.7.4

Claims for Damages

3.2.4, 3.18, 6.1.1, 8.3.3, 9.5.1, 9.6.7, 10.3.3, 11.1.1, 11.3.5, , 14.1.3, 14.2.4, 15.1.6

*(Paragraph deleted)*

Cleaning Up

3.15, 6.3

Commencement of the Work, Conditions Relating to

2.2.1, 3.2.2, 3.4.1, 3.7.1, 3.10.1, 3.12.6, 5.2.1, 5.2.3, 6.2.2, 8.1.2, 8.2.2, 8.3.1, 11.1, 11.3.1, 11.3.6, 11.4.1, 15.1.4

Commencement of the Work, Definition of

8.1.2

Communications Facilitating Contract

Administration

3.9.1, 4.2.4

Completion, Conditions Relating to

3.4.1, 3.11, 3.15, 4.2.2, 4.2.9, 8.2, 9.4.2, 9.8, 9.9.1, 9.10, 12.2, 13.7, 14.1.2

## COMPLETION, PAYMENTS AND

9

Completion, Substantial

4.2.9, 8.1.1, 8.1.3, 8.2.3, 9.4.2, 9.8, 9.9.1, 9.10.3, 12.2, 13.7

Compliance with Laws

1.6, 3.2.3, 3.6, 3.7, 3.12.10, 3.13, 4.1.1, 9.6.4, 10.2.2, 11.1, 11.3, 13.1, 13.4, 13.5.1, 13.5.2, 13.6, 14.1.1, 14.2.1.3, 15.2.8

Concealed or Unknown Conditions

3.7.4, 4.2.8, 8.3.1, 10.3

Conditions of the Contract

1.1.1, 6.1.1, 6.1.4

Consent, Written

3.4.2, 3.7.4, 3.12.8, 3.14.2, 4.1.2, 9.3.2, 9.8.5, 9.9.1, 9.10.2, 9.10.3, 11.3.1, 13.2, 13.4.2, 15.4.4.2

Consolidation or Joinder

15.4.4

## CONSTRUCTION BY OWNER OR BY SEPARATE CONTRACTORS

1.1.4, 6

Construction Change Directive, Definition of  
7.3.1

Construction Change Directives

1.1.1, 3.4.2, 3.12.8, 4.2.8, 7.1.1, 7.1.2, 7.1.3, 7.3, 9.3.1.1

Construction Schedules, Contractor's

3.10, 3.12.1, 3.12.2, 6.1.3, 15.1.5.2

Contingent Assignment of Subcontracts

5.4, 14.2.2.2

Continuing Contract Performance

15.1.3

Contract, Definition of

1.1.2

## CONTRACT, TERMINATION OR SUSPENSION OF THE

5.4.1.1, , 14

Contract Administration

3.1.3, 4, 9.4, 9.5

Contract Award and Execution, Conditions Relating to

3.7.1, 3.10, 5.2, 6.1, 11.1.3, 11.3.6, 11.4.1

Contract Documents, Copies Furnished and Use of  
1.5.2, 2.2.5, 5.3

Contract Documents, Definition of

1.1.1

Contract Sum

3.7.4, 3.8, 5.2.3, 7.2, 7.3, 7.4, 9.1, 9.4.2, 9.5.1.4, 9.6.7, 9.7, 10.3.2, 11.3.1, 14.2.4, 14.3.2, 15.1.4,

Contract Sum, Definition of

9.1

Contract Time

3.7.4, 3.7.5, 3.10.2, 5.2.3, 7.2.1.3, 7.3.1, 7.3.5, 7.4, 8.1.1, 8.2.1, 8.3.1, 9.5.1, 9.7, 10.3.2, 12.1.1, 14.3.2, 15.1.5.1,

Contract Time, Definition of

8.1.1

## CONTRACTOR

3

Contractor, Definition of

3.1, 6.1.2

Int.

AIA Document A201™ – 2007. Copyright © 1911, 1915, 1918, 1925, 1937, 1951, 1958, 1961, 1963, 1966, 1970, 1976, 1987, 1997 and 2007 by The American Institute of Architects. All rights reserved. **WARNING: This AIA® Document is protected by U.S. Copyright Law and International Treaties. Unauthorized reproduction or distribution of this AIA® Document, or any portion of it, may result in severe civil and criminal penalties, and will be prosecuted to the maximum extent possible under the law.** This document was produced by AIA software at 10:01:17 on 02/26/2018 under Order No.2737583500 which expires on 10/24/2018, and is not for resale

User Notes:

(1953391157)

## **Contractor's Construction Schedules**

3.10, 3.12.1, 3.12.2, 6.1.3, 15.1.5.2

### **Contractor's Employees**

3.3.2, 3.4.3, 3.8.1, 3.9, 3.18.2, 4.2.3, 4.2.6, 10.2, 10.3, 11.1.1, , 14.1, 14.2.1.1

### **Contractor's Liability Insurance**

#### **11.1**

#### **Contractor's Relationship with Separate Contractors and Owner's Forces**

3.12.5, 3.14.2, 4.2.4, 6, , 12.1.2, 12.2.4

#### **Contractor's Relationship with Subcontractors**

1.2.2, 3.3.2, 3.18.1, 3.18.2, 5, 9.6.2, 9.6.7, 9.10.2, 11.3.1.2, ,

#### **Contractor's Relationship with the Architect**

1.1.2, 1.5, 3.1.3, 3.2.2, 3.2.3, 3.2.4, 3.3.1, 3.4.2, 3.5, 3.7.4, 3.10, 3.11, 3.12, 3.16, 3.18, 4.1.3, 4.2, 5.2, 6.2.2, 7, 8.3.1, 9.2, 9.3, 9.4, 9.5, 9.7, 9.8, 9.9, 10.2.6, 10.3, , 12, 13.5, 15.1.2,

#### **Contractor's Representations**

3.2.1, 3.2.2, 3.5, 3.12.6, 6.2.2, 8.2.1, 9.3.3, 9.8.2

#### **Contractor's Responsibility for Those Performing the Work**

3.3.2, 3.18, 5.3, 6.1.3, 6.2, 9.5.1, 10.2.8

#### **Contractor's Review of Contract Documents**

3.2

#### **Contractor's Right to Stop the Work**

9.7

#### **Contractor's Right to Terminate the Contract**

14.1, 15.1.6

#### **Contractor's Submittals**

3.10, 3.11, 3.12.4, 4.2.7, 5.2.1, 5.2.3, 9.2, 9.3, 9.8.2, 9.8.3, 9.9.1, 9.10.2, 9.10.3, 11.1.3, 11.4.2

#### **Contractor's Superintendent**

3.9, 10.2.6

#### **Contractor's Supervision and Construction**

##### **Procedures**

1.2.2, 3.3, 3.4, 3.12.10, 4.2.2, 4.2.7, 6.1.3, 6.2.4, 7.1.3, 7.3.5, 7.3.7, 8.2, 10, 12, 14, 15.1.3

#### **Contractual Liability Insurance**

11., 11.2

#### **Coordination and Correlation**

1.2, 3.2.1, 3.3.1, 3.10, 3.12.6, 6.1.3, 6.2.1

#### **Copies Furnished of Drawings and Specifications**

1.5, 2.2.5, 3.11

#### **Copyrights**

1.5, 3.17

#### **Correction of Work**

2.3, 2.4, 3.7.3, 9.4.2, 9.8.2, 9.8.3, 9.9.1, 12.1.2, 12.2

#### **Correlation and Intent of the Contract Documents**

1.2

#### **Cost, Definition of**

7.3.7

#### **Costs**

2.4, 3.2.4, 3.7.3, 3.8.2, 3.15.2, 5.4.2, 6.1.1, 6.2.3, 7.3.3.3, 7.3.7, 7.3.8, 7.3.9, 9.10.2, 10.3.2, 10.3.6, 11.3, 12.1.2, 12.2.1, 12.2.4, 13.5, 14

#### **Cutting and Patching**

3.14, 6.2.5

#### **Damage to Construction of Owner or Separate Contractors**

3.14.2, 6.2.4, 10.2.1.2, 10.2.5, 10.4, 11.1.1, 11.3, 12.2.4

#### **Damage to the Work**

3.14.2, 9.9.1, 10.2.1.2, 10.2.5, 10.4, 11.3.1, 12.2.4

#### **Damages, Claims for**

3.2.4, 3.18, 6.1.1, 8.3.3, 9.5.1, 9.6.7, 10.3.3, 11.1.1, 11.3.5, , 14.1.3, 14.2.4, 15.1.6

#### **Damages for Delay**

6.1.1, 8.3.3, 9.5.1.6, 9.7, 10.3.2

#### **Date of Commencement of the Work, Definition of 8.1.2**

#### **Date of Substantial Completion, Definition of 8.1.3**

#### **Day, Definition of**

8.1.4

#### **Decisions of the Architect**

3.7.4, 4.2.6, 4.2.7, 4.2.11, 4.2.12, 4.2.13, 15.2, 6.3, 7.3.7, 7.3.9, 8.1.3, 8.3.1, 9.2, 9.4, 9.5.1, 9.8.4, 9.9.1, 13.5.2, 14.2.2, 14.2.4, 15.1, 15.2

#### **Decisions to Withhold Certification**

9.4.1, 9.5, 9.7, 14.1.1.3

#### **Defective or Nonconforming Work, Acceptance, Rejection and Correction of**

2.3, 2.4, 3.5, 4.2.6, 6.2.5, 9.5.1, 9.5.2, 9.6.6, 9.8.2, 9.9.3, 9.10.4, 12.2.1

#### **Definitions**

1.1, 2.1.1, 3.1.1, 3.5, 3.12.1, 3.12.2, 3.12.3, 4.1.1, 15.1.1, 5.1, 6.1.2, 7.2.1, 7.3.1, 8.1, 9.1, 9.8.1

#### **Delays and Extensions of Time**

3.2, 3.7.4, 5.2.3, 7.2.1, 7.3.1, 7.4, 8.3, 9.5.1, 9.7, 10.3.2, 10.4, 14.3.2, 15.1.5,

#### **Disputes**

6.3, 7.3.9, 15.1, 15.2

#### **Documents and Samples at the Site**

3.11

#### **Drawings, Definition of**

1.1.5

#### **Drawings and Specifications, Use and Ownership of 3.11**

#### **Effective Date of Insurance**

8.2.2, 11.1.2

#### **Emergencies**

10.4, 14.1.1.2, 15.1.4

#### **Employees, Contractor's**

3.3.2, 3.4.3, 3.8.1, 3.9, 3.18.2, 4.2.3, 4.2.6, 10.2, 10.3.3, 11.1.1, , 14.1, 14.2.1.1

Init.

Equipment, Labor, Materials or  
1.1.3, 1.1.6, 3.4, 3.5, 3.8.2, 3.8.3, 3.12, 3.13, 3.15.1,  
4.2.6, 4.2.7, 5.2.1, 6.2.1, 7.3.7, 9.3.2, 9.3.3, 9.5.1.3,  
9.10.2, 10.2.1, 10.2.4, 14.2.1.1, 14.2.1.2  
Execution and Progress of the Work  
1.1.3, 1.2.1, 1.2.2, 2.2.3, 2.2.5, 3.1, 3.3.1, 3.4.1, 3.5,  
3.7.1, 3.10.1, 3.12, 3.14, 4.2, 6.2.2, 7.1.3, 7.3.5, 8.2,  
9.5.1, 9.9.1, 10.2, 10.3, 12.2, 14.2, 14.3.1, 15.1.3  
Extensions of Time  
3.2.4, 3.7.4, 5.2.3, 7.2.1, 7.3, 7.4, 9.5.1, 9.7, 10.3.2,  
10.4, 14.3, 15.1.5,

#### **Failure of Payment**

9.5.1.3, 9.7, 9.10.2, 13.6, 14.1.1.3, 14.2.1.2

#### **Faulty Work**

(See Defective or Nonconforming Work)

#### **Final Completion and Final Payment**

4.2.1, 4.2.9, 9.8.2, 9.10, 11.1.2, 11.1.3, 11.3.1, 11.3.5,  
12.3, 14.2.4, 14.4.3

#### **Financial Arrangements, Owner's**

2.2.1, 13.2.2, 14.1.1.4

#### **Fire and Extended Coverage Insurance**

11.3.1.1

### **GENERAL PROVISIONS**

#### **1**

#### **Governing Law**

13.1

#### **Guarantees (See Warranty)**

#### **Hazardous Materials**

10.2.4, 10.3

#### **Identification of Subcontractors and Suppliers**

5.2.1

#### **Indemnification**

3.17, 3.18, 9.10.2, 10.3.3, 10.3.5, 10.3.6, 11.3.1.2,

#### **Information and Services Required of the Owner**

2.1.2, 2.2, 3.2.2, 3.12.4, 3.12.10, 6.1.3, 6.1.4, 6.2.5,  
9.6.1, 9.6.4, 9.9.2, 9.10.3, 10.3.3, 11.2, 11.4, 13.5.1,  
13.5.2, 14.1.1.4, 14.1.4, 15.1.3

#### **Initial Decision**

15.2

(Paragraph deleted)

(Paragraphs deleted)

#### **Injury or Damage to Person or Property**

10.2.8, 10.4

#### **Inspections**

3.1.3, 3.3.3, 3.7.1, 4.2.2, 4.2.6, 4.2.9, 9.4.2, 9.8.3,  
9.9.2, 9.10.1, 12.2.1, 13.5

#### **Instructions to Bidders**

1.1.1

#### **Instructions to the Contractor**

3.2.4, 3.3.1, 3.8.1, 5.2.1, 7, 8.2.2, 12, 13.5.2

#### **Instruments of Service, Definition of**

1.1.7

#### **Insurance**

3.18.1, 6.1.1, 7.3.7, 9.3.2, 9.8.4, 9.9.1, 9.10.2, 11

#### **Insurance, Boiler and Machinery**

11.3.2

#### **Insurance, Contractor's Liability**

11.1

#### **Insurance, Effective Date of**

8.2.2, 11.1.2

#### **Insurance, Loss of Use**

11.3.3

#### **Insurance, Owner's Liability**

11.2

#### **Insurance, Property**

10.2.5, 11.3

#### **Insurance, Stored Materials**

9.3.2

### **INSURANCE AND BONDS**

#### **11**

#### **Insurance Companies, Consent to Partial Occupancy**

9.9.1

#### **Intent of the Contract Documents**

1.2.1, 4.2.7, 4.2.12, 4.2.13, 7.4

#### **Interest**

13.6

#### **Interpretation**

1.2.3, 1.4, 4.1.1, 5.1, 6.1.2, 15.1.1

#### **Interpretations, Written**

4.2.11, 4.2.12, 15.1.4

#### **Labor and Materials, Equipment**

1.1.3, 1.1.6, 3.4, 3.5, 3.8.2, 3.8.3, 3.12, 3.13, 3.15.1,  
4.2.6, 4.2.7, 5.2.1, 6.2.1, 7.3.7, 9.3.2, 9.3.3, 9.5.1.3,  
9.10.2, 10.2.1, 10.2.4, 14.2.1.1, 14.2.1.2

#### **Labor Disputes**

8.3.1

#### **Laws and Regulations**

1.5, 3.2.3, 3.6, 3.7, 3.12.10, 3.13, 4.1.1, 9.6.4, 9.9.1,  
10.2.2, 11.1.1, 11.3, 13.1, 13.4, 13.5.1, 13.5.2, 13.6,  
14, 15.2.8

#### **Liens**

2.1.2, 9.3.3, 9.10.2, 9.10.4, 15.2.8

#### **Limitations, Statutes of**

12.2.5, 13.7

#### **Limitations of Liability**

2.3, 3.2.2, 3.5, 3.12.10, 3.17, 3.18.1, 4.2.6, 4.2.7,  
4.2.12, 6.2.2, 9.4.2, 9.6.4, 9.6.7, 10.2.5, 10.3.3, 11.1.2,  
11.2, , 12.2.5, 13.4.2

#### **Limitations of Time**

2.1.2, 2.2, 2.4, 3.2.2, 3.10, 3.11, 3.12.5, 3.15.1, 4.2.7,  
5.2, 5.3, 5.4.1, 6.2.4, 7.3, 7.4, 8.2, 9.2, 9.3.1, 9.3.3,  
9.4.1, 9.5, 9.6, 9.7, 9.8, 9.9, 9.10, 11.1.3, 11.3.1.5,  
11.3.6, , 12.2, 13.5, 13.7, 14, 15

#### **Loss of Use Insurance**

11.3.3

#### **Material Suppliers**

1.5, 3.12.1, 4.2.4, 4.2.6, 5.2.1, 9.3, 9.4.2, 9.6, 9.10.5

#### **Materials, Hazardous**

10.2.4, 10.3

Init.

AIA Document A201™ – 2007. Copyright © 1911, 1915, 1918, 1925, 1937, 1951, 1958, 1961, 1963, 1966, 1970, 1976, 1987, 1997 and 2007 by The American Institute of Architects. All rights reserved. **WARNING: This AIA® Document is protected by U.S. Copyright Law and International Treaties. Unauthorized reproduction or distribution of this AIA® Document, or any portion of it, may result in severe civil and criminal penalties, and will be prosecuted to the maximum extent possible under the law.** This document was produced by AIA software at 10:01:17 on 02/26/2018 under Order No.2737583500 which expires on 10/24/2018 and is not for resale.

User Notes:

(1953391157)

Materials, Labor, Equipment and  
 1.1.3, 1.1.6, 1.5.1, 3.4.1, 3.5, 3.8.2, 3.8.3, 3.12, 3.13,  
 3.15.1, 4.2.6, 4.2.7, 5.2.1, 6.2.1, 7.3.7, 9.3.2, 9.3.3,  
 9.5.1.3, 9.10.2, 10.2.1.2, 10.2.4, 14.2.1.1, 14.2.1.2

Means, Methods, Techniques, Sequences and  
 Procedures of Construction  
 3.3.1, 3.12.10, 4.2.2, 4.2.7, 9.4.2

Mechanic's Lien  
 2.1.2, 15.2.8

Mediation  
 8.3.1, 10.3.5, 10.3.6,

Minor Changes in the Work  
 1.1.1, 3.12.8, 4.2.8, 7.1, 7.4

**MISCELLANEOUS PROVISIONS**  
**13**

**Modifications, Definition of**  
**1.1.1**  
 Modifications to the Contract  
 1.1.1, 1.1.2, 3.11, 4.1.2, 4.2.1, 5.2.3, 7, 8.3.1, 9.7,  
 10.3.2, 11.3.1

**Mutual Responsibility**  
**6.2**

**Nonconforming Work, Acceptance of**  
 9.6.6, 9.9.3, **12.3**

Nonconforming Work, Rejection and Correction of  
 2.3, 2.4, 3.5, 4.2.6, 6.2.4, 9.5.1, 9.8.2, 9.9.3, 9.10.4,  
 12.2.1

Notice  
 2.2.1, 2.3, 2.4, 3.2.4, 3.3.1, 3.7.2, 3.12.9, 5.2.1, 9.7,  
 9.10, 10.2.2, 11.1.3, 12.2.2.1, 13.3, 13.5.1, 13.5.2,  
 14.1, 14.2, 15.2.8

Notice, Written  
 2.3, 2.4, 3.3.1, 3.9.2, 3.12.9, 3.12.10, 5.2.1, 9.7, 9.10,  
 10.2.2, 10.3, 11.1.3, 11.3.6, 12.2.2.1, **13.3**, 14, 15.2.8,

Notice of Claims  
 3.7.4, 10.2.8, **15.1.2**

Notice of Testing and Inspections  
 13.5.1, 13.5.2

Observations, Contractor's  
 3.2, 3.7.4

Occupancy  
 2.2.2, 9.6.6, 9.8, 11.3.1.5

Orders, Written  
 1.1.1, 2.3, 3.9.2, 7, 8.2.2, , 12.1, 12.2.2.1, 13.5.2,  
 14.3.1

**OWNER**  
**2**

**Owner, Definition of**  
**2.1.1**

**Owner, Information and Services Required of the**  
 2.1.2, **2.2**, 3.2.2, 3.12.10, 6.1.3, 6.1.4, 6.2.5, 9.3.2,  
 9.6.1, 9.6.4, 9.9.2, 9.10.3, 10.3.3, 11.2, 11.3, 13.5.1,  
 13.5.2, 14.1.1.4, 14.1.4, 15.1.3

Owner's Authority  
 1.5, 2.1.1, 2.3, 2.4, 3.4.2, 3.8.1, 3.12.10, 3.14.2, 4.1.2,  
 4.1.3, 4.2.4, 4.2.9, 5.2.1, 5.2.4, 5.4.1, 6.1, 6.3, 7.2.1,  
 7.3.1, 8.2.2, 8.3.1, 9.3.1, 9.3.2, 9.5.1, 9.6.4, 9.9.1,  
 9.10.2, 10.3.2, 11.1.3, 11.3.3, , 12.2.2, 12.3, 13.2.2,  
 14.3, 14.4, 15.2.7

Owner's Financial Capability  
 2.2.1, 13.2.2, 14.1.1.4

**Owner's Liability Insurance**  
**11.2**

Owner's Relationship with Subcontractors  
 1.1.2, 5.2, 5.3, 5.4, 9.6.4, 9.10.2, 14.2.2

**Owner's Right to Carry Out the Work**  
**2.4**, 14.2.2

**Owner's Right to Clean Up**  
**6.3**

**Owner's Right to Perform Construction and to Award Separate Contracts**  
**6.1**

**Owner's Right to Stop the Work**  
**2.3**

Owner's Right to Suspend the Work  
 14.3

Owner's Right to Terminate the Contract  
 14.2

**Ownership and Use of Drawings, Specifications and Other Instruments of Service**  
 1.1.1, 1.1.6, 1.1.7, **1.5**, 2.2.5, 3.2.2, 3.11, 3.17, 4.2.12,  
 5.3

**Partial Occupancy or Use**  
 9.6.6, **9.9**, 11.3.1.5

**Patching, Cutting and**  
**3.14**, 6.2.5

Patents  
 3.17

**Payment, Applications for**  
 4.2.5, 7.3.9, 9.2, **9.3**, 9.4, 9.5, 9.6.3, 9.7, 9.8.5, 9.10.1,  
 14.2.3, 14.2.4, 14.4.3

**Payment, Certificates for**  
 4.2.5, 4.2.9, 9.3.3, 9.4, 9.5, 9.6.1, 9.6.6, 9.7, 9.10.1,  
 9.10.3, 13.7, 14.1.1.3, 14.2.4

**Payment, Failure of**  
 9.5.1.3, **9.7**, 9.10.2, 13.6, 14.1.1.3, 14.2.1.2

Payment, Final  
 4.2.1, 4.2.9, 9.8.2, 9.10, 11.1.2, 11.1.3, 11.4.1, 12.3,  
 13.7, 14.2.4, 14.4.3

**Payment Bond, Performance Bond and**  
**7.3.7.4**, 9.6.7, 9.10.3, **11.4**

**Payments, Progress**  
 9.3, **9.6**, 9.8.5, 9.10.3, 13.6, 14.2.3, 15.1.3

**PAYMENTS AND COMPLETION**  
**9**

Payments to Subcontractors  
 5.4.2, 9.5.1.3, 9.6.2, 9.6.3, 9.6.4, 9.6.7, 14.2.1.2

PCB  
 10.3.1

**Performance Bond and Payment Bond**  
7.3.7.4, 9.6.7, 9.10.3, 11.4

**Permits, Fees, Notices and Compliance with Laws**  
2.2.2, 3.7, 3.13, 7.3.7.4, 10.2.2

**PERSONS AND PROPERTY, PROTECTION OF**  
**10**

**Polychlorinated Biphenyl**  
10.3.1

**Product Data, Definition of**  
3.12.2

**Product Data and Samples, Shop Drawings**  
3.11, 3.12, 4.2.7

**Progress and Completion**  
4.2.2, 8.2, 9.8, 9.9.1, 14.1.4, 15.1.3

**Progress Payments**  
9.3, 9.6, 9.8.5, 9.10.3, 13.6, 14.2.3, 15.1.3

**Project, Definition of**  
1.1.4

**Project Representatives**  
4.2.10

**Property Insurance**  
10.2.5, 11.3

**PROTECTION OF PERSONS AND PROPERTY**  
**10**

**Regulations and Laws**  
1.5, 3.2.3, 3.6, 3.7, 3.12.10, 3.13, 4.1.1, 9.6.4, 9.9.1,  
10.2.2, 11.1, 11.4, 13.1, 13.4, 13.5.1, 13.5.2, 13.6, 14,  
15.2.8

**Rejection of Work**  
3.5, 4.2.6, 12.2.1

**Releases and Waivers of Liens**  
9.10.2

**Representations**  
3.2.1, 3.5, 3.12.6, 6.2.2, 8.2.1, 9.3.3, 9.4.2, 9.5.1, 9.8.2,  
9.10.1

**Representatives**  
2.1.1, 3.1.1, 3.9, 4.1.1, 4.2.1, 4.2.2, 4.2.10, 5.1.1, 5.1.2,  
13.2.1

**Responsibility for Those Performing the Work**  
3.3.2, 3.18, 4.2.3, 5.3, 6.1.3, 6.2, 6.3, 9.5.1, 10

**Retainage**  
9.3.1, 9.6.2, 9.8.5, 9.9.1, 9.10.2, 9.10.3

**Review of Contract Documents and Field**  
**Conditions by Contractor**  
3.2, 3.12.7, 6.1.3

**Review of Contractor's Submittals by Owner and**  
**Architect**  
3.10.1, 3.10.2, 3.11, 3.12, 4.2, 5.2, 6.1.3, 9.2, 9.8.2

**Review of Shop Drawings, Product Data and Samples**  
**by Contractor**  
3.12

**Rights and Remedies**  
1.1.2, 2.3, 2.4, 3.5, 3.7.4, 3.15.2, 4.2.6, 5.3, 5.4, 6.1,  
6.3, 7.3.1, 8.3, 9.5.1, 9.7, 10.2.5, 10.3, 12.2.2, 12.2.4,  
13.4, 14

**Royalties, Patents and Copyrights**  
3.17

*(Paragraphs deleted)*

**Safety of Persons and Property**  
10.2, 10.4

**Safety Precautions and Programs**  
3.3.1, 4.2.2, 4.2.7, 5.3, 10.1, 10.2, 10.4

**Samples, Definition of**  
3.12.3

**Samples, Shop Drawings, Product Data and**  
3.11, 3.12, 4.2.7

**Samples at the Site, Documents and**  
3.11

**Schedule of Values**  
9.2, 9.3.1

**Schedules, Construction**  
3.10, 3.12.1, 3.12.2, 6.1.3, 15.1.5.2

**Separate Contracts and Contractors**  
1.1.4, 3.12.5, 3.14.2, 4.2.4, 4.2.7, 6, 8.3.1, 12.1.2

**Shop Drawings, Definition of**  
3.12.1

**Shop Drawings, Product Data and Samples**  
3.11, 3.12, 4.2.7

**Site, Use of**  
3.13, 6.1.1, 6.2.1

**Site Inspections**  
3.2.2, 3.3.3, 3.7.1, 3.7.4, 4.2, 9.4.2, 9.10.1, 13.5

**Site Visits, Architect's**  
3.7.4, 4.2.2, 4.2.9, 9.4.2, 9.5.1, 9.9.2, 9.10.1, 13.5

**Special Inspections and Testing**  
4.2.6, 12.2.1, 13.5

**Specifications, Definition of**  
1.1.6

**Specifications**  
1.1.1, 1.1.6, 1.2.2, 1.5, 3.11, 3.12.10, 3.17, 4.2.14

**Statute of Limitations**  
13.7

**Stopping the Work**  
2.3, 9.7, 10.3, 14.1

**Stored Materials**  
6.2.1, 9.3.2, 10.2.1.2, 10.2.4

**Subcontractor, Definition of**  
5.1.1

**SUBCONTRACTORS**  
5

**Subcontractors, Work by**  
1.2.2, 3.3.2, 3.12.1, 4.2.3, 5.2.3, 5.3, 5.4, 9.3.1.2, 9.6.7

**Subcontractual Relations**  
5.3, 5.4, 9.3.1.2, 9.6, 9.10, 10.2.1, 14.1, 14.2.1

**Submittals**  
3.10, 3.11, 3.12, 4.2.7, 5.2.1, 5.2.3, 7.3.7, 9.2, 9.3, 9.8,  
9.9.1, 9.10.2, 9.10.3, 11.1.3

**Submittal Schedule**  
3.10.2, 3.12.5, 4.2.7

**Subrogation, Waivers of**  
6.1.1,

**Substantial Completion**  
4.2.9, 8.1.1, 8.1.3, 8.2.3, 9.4.2, 9.8, 9.9.1, 9.10.3, 12.2,  
13.7

**Substantial Completion, Definition of**  
**9.8.1**  
 Substitution of Subcontractors  
 5.2.3, 5.2.4  
 Substitution of Architect  
 4.1.3  
 Substitutions of Materials  
 3.4.2, 3.5, 7.3.8  
**Sub-subcontractor, Definition of**  
**5.1.2**  
 Subsurface Conditions  
 3.7.4  
**Successors and Assigns**  
**13.2**  
**Superintendent**  
 3.9, 10.2.6  
**Supervision and Construction Procedures**  
 1.2.2, 3.3, 3.4, 3.12.10, 4.2.2, 4.2.7, 6.1.3, 6.2.4, 7.1.3,  
 7.3.7, 8.2, 8.3.1, 9.4.2, 10, 12, 14, 15.1.3  
 Surety  
 5.4.1.2, 9.8.5, 9.10.2, 9.10.3, 14.2.2, 15.2.7  
 Surety, Consent of  
 9.10.2, 9.10.3  
 Surveys  
 2.2.3  
**Suspension by the Owner for Convenience**  
**14.3**  
 Suspension of the Work  
 5.4.2, 14.3  
 Suspension or Termination of the Contract  
 5.4.1.1, 14  
**Taxes**  
 3.6, 3.8.2.1, 7.3.7.4  
**Termination by the Contractor**  
 14.1, 15.1.6  
**Termination by the Owner for Cause**  
 5.4.1.1, 14.2, 15.1.6  
**Termination by the Owner for Convenience**  
**14.4**  
 Termination of the Architect  
 4.1.3  
 Termination of the Contractor  
 14.2.2  
**TERMINATION OR SUSPENSION OF THE CONTRACT**  
**14**  
**Tests and Inspections**  
 3.1.3, 3.3.3, 4.2.2, 4.2.6, 4.2.9, 9.4.2, 9.8.3, 9.9.2,  
 9.10.1, 10.3.2, 11.4.1, 12.2.1, 13.5  
**TIME**  
**8**  
**Time, Delays and Extensions of**  
 3.2.4, 3.7.4, 5.2.3, 7.2.1, 7.3.1, 7.4, 8.3, 9.5.1, 9.7,  
 10.3.2, 10.4, 14.3.2, 15.1.5,

Time Limits  
 2.1.2, 2.2, 2.4, 3.2.2, 3.10, 3.11, 3.12.5, 3.15.1, 4.2,  
 5.2, 5.3, 5.4, 6.2.4, 7.3, 7.4, 8.2, 9.2, 9.3.1, 9.3.3, 9.4.1,  
 9.5, 9.6, 9.7, 9.8, 9.9, 9.10, 11.1.3, 12.2, 13.5, 13.7, 14,  
 15.1.2  
**Time Limits on Claims**  
 3.7.4, 10.2.8, 13.7, 15.1.2  
 Title to Work  
 9.3.2, 9.3.3  
**Transmission of Data in Digital Form**  
**1.6**  
**UNCOVERING AND CORRECTION OF WORK**  
**12**  
**Uncovering of Work**  
**12.1**  
 Unforeseen Conditions, Concealed or Unknown  
 3.7.4, 8.3.1, 10.3  
 Unit Prices  
 7.3.3.2, 7.3.4  
 Use of Documents  
 1.1.1, 1.5, 2.2.5, 3.12.6, 5.3  
**Use of Site**  
 3.13, 6.1.1, 6.2.1  
**Values, Schedule of**  
 9.2, 9.3.1  
 Waiver of Claims by the Architect  
 13.4.2  
 Waiver of Claims by the Contractor  
 9.10.5, 13.4.2, 15.1.6  
 Waiver of Claims by the Owner  
 9.9.3, 9.10.3, 9.10.4, 12.2.2.1, 13.4.2, 14.2.4, 15.1.6  
 Waiver of Consequential Damages  
 14.2.4, 15.1.6  
 Waiver of Liens  
 9.10.2, 9.10.4  
**Waivers of Subrogation**  
 6.1.1,  
**Warranty**  
 3.5, 4.2.9, 9.3.3, 9.8.4, 9.9.1, 9.10.4, 12.2.2, 13.7  
 Weather Delays  
 15.1.5.2  
**Work, Definition of**  
**1.1.3**  
 Written Consent  
 1.5.2, 3.4.2, 3.7.4, 3.12.8, 3.14.2, 4.1.2, 9.3.2, 9.8.5,  
 9.9.1, 9.10.2, 9.10.3, 11.4.1, 13.2, 13.4.2, 15.4.4.2  
 Written Interpretations  
 4.2.11, 4.2.12  
 Written Notice  
 2.3, 2.4, 3.3.1, 3.9, 3.12.9, 3.12.10, 5.2.1, 8.2.2, 9.7,  
 9.10, 10.2.2, 10.3, 11.1.3, 12.2.2, 12.2.4, 13.3, 14  
 Written Orders  
 1.1.1, 2.3, 3.9, 7, 8.2.2, 12.1, 12.2, 13.5.2, 14.3.1,  
 15.1.2

## ARTICLE 1 GENERAL PROVISIONS

### § 1.1 BASIC DEFINITIONS

#### § 1.1.1 THE CONTRACT DOCUMENTS

The Contract Documents are enumerated in the Agreement between the Owner and Contractor (hereinafter the Agreement) and consist of the Agreement, Conditions of the Contract (General, Supplementary and other Conditions), Drawings, Specifications, Addenda issued prior to execution of the Contract, other documents listed in the Agreement and Modifications issued after execution of the Contract. A Modification is (1) a written amendment to the Contract signed by both parties, (2) a Change Order, or (3) a Construction Change Directive. Unless specifically enumerated in the Agreement, the Contract Documents do not include the advertisement or invitation to bid, Instructions to Bidders, sample forms, other information furnished by the Owner in anticipation of receiving bids or proposals, the Contractor's bid or proposal, or portions of Addenda relating to bidding requirements.

#### § 1.1.2 THE CONTRACT

The Contract Documents form the Contract for Construction. The Contract represents the entire and integrated agreement between the parties hereto and supersedes prior negotiations, representations or agreements, either written or oral. The Contract may be amended or modified only by a Modification. The Contract Documents shall not be construed to create a contractual relationship of any kind (1) between the Contractor and the Architect or the Architect's consultants, (2) between the Owner and a Subcontractor or a Sub-subcontractor, (3) between the Owner and the Architect or the Architect's consultants or (4) between any persons or entities other than the Owner and the Contractor. The Architect shall, however, be entitled to performance and enforcement of obligations under the Contract intended to facilitate performance of the Architect's duties.

#### § 1.1.3 THE WORK

The term "Work" means the construction and services required by the Contract Documents, whether completed or partially completed, and includes all other labor, materials, equipment and services provided or to be provided by the Contractor to fulfill the Contractor's obligations. The Work may constitute the whole or a part of the Project.

#### § 1.1.4 THE PROJECT

The Project is the total construction of which the Work performed under the Contract Documents may be the whole or a part and which may include construction by the Owner and by separate contractors.

#### § 1.1.5 THE DRAWINGS

The Drawings are the graphic and pictorial portions of the Contract Documents showing the design, location and dimensions of the Work, generally including plans, elevations, sections, details, schedules and diagrams.

#### § 1.1.6 THE SPECIFICATIONS

The Specifications are that portion of the Contract Documents consisting of the written requirements for materials, equipment, systems, standards and workmanship for the Work, and performance of related services.

#### § 1.1.7 INSTRUMENTS OF SERVICE

Instruments of Service are representations, in any medium of expression now known or later developed, of the tangible and intangible creative work performed by the Architect and the Architect's consultants under their respective professional services agreements. Instruments of Service may include, without limitation, studies, surveys, models, sketches, drawings, specifications, and other similar materials.

*(Paragraphs deleted)*

### § 1.2 CORRELATION AND INTENT OF THE CONTRACT DOCUMENTS

§ 1.2.1 The intent of the Contract Documents is to include all items necessary for the proper execution and completion of the Work by the Contractor. The Contract Documents are complementary, and what is required by one shall be as binding as if required by all; performance by the Contractor shall be required only to the extent consistent with the Contract Documents and reasonably inferable from them as being necessary to produce the indicated results.

§ 1.2.2 Organization of the Specifications into divisions, sections and articles, and arrangement of Drawings shall not control the Contractor in dividing the Work among Subcontractors or in establishing the extent of Work to be performed by any trade.

§ 1.2.3 Unless otherwise stated in the Contract Documents, words that have well-known technical or construction industry meanings are used in the Contract Documents in accordance with such recognized meanings.

### § 1.3 CAPITALIZATION

Terms capitalized in these General Conditions include those that are (1) specifically defined, (2) the titles of numbered articles or (3) the titles of other documents published by the American Institute of Architects.

### § 1.4 INTERPRETATION

In the interest of brevity the Contract Documents frequently omit modifying words such as "all" and "any" and articles such as "the" and "an," but the fact that a modifier or an article is absent from one statement and appears in another is not intended to affect the interpretation of either statement.

### § 1.5 OWNERSHIP AND USE OF DRAWINGS, SPECIFICATIONS AND OTHER INSTRUMENTS OF SERVICE

§ 1.5.1 The City of Evanston shall be deemed the owners of the Instruments of Service, including the Drawings and Specifications, and will retain all common law, statutory and other reserved rights, including copyrights. The Contractor, Subcontractors, Sub-subcontractors, and material or equipment suppliers shall not own or claim a copyright in the Instruments of Service. Submittal or distribution to meet official regulatory requirements or for other purposes in connection with this Project is not to be construed as publication in derogation of the City of Evanston's reserved rights.

§ 1.5.2 The Contractor, Subcontractors, Sub-subcontractors and material or equipment suppliers are authorized to use and reproduce the Instruments of Service provided to them solely and exclusively for execution of the Work. All copies made under this authorization shall bear the copyright notice, if any, shown on the Instruments of Service. The Contractor, Subcontractors, Sub-subcontractors, and material or equipment suppliers may not use the Instruments of Service on other projects or for additions to this Project outside the scope of the Work without the specific written consent of the Owner, Architect and the Architect's consultants.

### § 1.6 TRANSMISSION OF DATA IN DIGITAL FORM

If the parties intend to transmit Instruments of Service or any other information or documentation in digital form, they shall endeavor to establish necessary protocols governing such transmissions, unless otherwise already provided in the Agreement or the Contract Documents.

## ARTICLE 2 OWNER

### § 2.1 GENERAL

§ 2.1.1 The Owner is the person or entity identified as such in the Agreement and is referred to throughout the Contract Documents as if singular in number. The Owner shall designate in writing a representative who shall have express authority to bind the Owner with respect to all matters requiring the Owner's approval or authorization. Except as otherwise provided in Section 4.2.1, the Architect does not have such authority. The term "Owner" means the Owner or the Owner's authorized representative.

§ 2.1.2 The Owner shall furnish to the Contractor within fifteen days after receipt of a written request, information necessary and relevant for the Contractor to evaluate, give notice of or enforce mechanic's lien rights. Such information shall include a correct statement of the record legal title to the property on which the Project is located, usually referred to as the site, and the Owner's interest therein.

### § 2.2 INFORMATION AND SERVICES REQUIRED OF THE OWNER

§ 2.2.1 Prior to commencement of the Work, the Contractor may request in writing that the Owner provide reasonable evidence that the Owner has made financial arrangements to fulfill the Owner's obligations under the Contract. Thereafter, the Contractor may only request such evidence if (1) the Owner fails to make payments to the Contractor as the Contract Documents require; (2) a change in the Work materially changes the Contract Sum; or (3) the Contractor identifies in writing a reasonable concern regarding the Owner's ability to make payment when due. The Owner shall furnish such evidence as a condition precedent to commencement or continuation of the Work or the portion of the Work affected by a material change. After the Owner furnishes the evidence, the Owner shall not materially vary such financial arrangements without prior notice to the Contractor.

§ 2.2.2 Except for permits and fees that are the responsibility of the Contractor under the Contract Documents, including those required under Section 3.7.1, the Owner shall secure and pay for necessary approvals, easements,

Init.



assessments and charges required for construction, use or occupancy of permanent structures or for permanent changes in existing facilities.

§ 2.2.3 The Owner shall furnish surveys describing physical characteristics, legal limitations and utility locations for the site of the Project, and a legal description of the site. The Contractor shall be entitled to rely on the accuracy of information furnished by the Owner but shall exercise proper precautions relating to the safe performance of the Work.

§ 2.2.4 The Owner shall furnish information or services required of the Owner by the Contract Documents with reasonable promptness. The Owner shall also furnish any other information or services under the Owner's control and relevant to the Contractor's performance of the Work with reasonable promptness after receiving the Contractor's written request for such information or services.

§ 2.2.5 Unless otherwise provided in the Contract Documents, the Owner shall furnish to the Contractor one copy of the Contract Documents for purposes of making reproductions pursuant to Section 1.5.2.

### § 2.3 OWNER'S RIGHT TO STOP THE WORK

If the Contractor fails to correct Work that is not in accordance with the requirements of the Contract Documents as required by Section 12.2 or repeatedly fails to carry out Work in accordance with the Contract Documents, the Owner may issue a written order to the Contractor to stop the Work, or any portion thereof, until the cause for such order has been eliminated; however, the right of the Owner to stop the Work shall not give rise to a duty on the part of the Owner to exercise this right for the benefit of the Contractor or any other person or entity, except to the extent required by Section 6.1.3.

### § 2.4 OWNER'S RIGHT TO CARRY OUT THE WORK

If the Contractor defaults or neglects to carry out the Work in accordance with the Contract Documents and fails within a ten-day period after receipt of written notice from the Owner to commence and continue correction of such default or neglect with diligence and promptness, the Owner may, without prejudice to other remedies the Owner may have, correct such deficiencies. In such case an appropriate Change Order shall be issued deducting from payments then or thereafter due the Contractor the reasonable cost of correcting such deficiencies, including Owner's expenses and compensation for the Architect's additional services made necessary by such default, neglect or failure. Such action by the Owner and amounts charged to the Contractor are both subject to prior approval of the Architect. If payments then or thereafter due the Contractor are not sufficient to cover such amounts, the Contractor shall pay the difference to the Owner.

## ARTICLE 3 CONTRACTOR

### § 3.1 GENERAL

§ 3.1.1 The Contractor is the person or entity identified as such in the Agreement and is referred to throughout the Contract Documents as if singular in number. The Contractor shall be lawfully licensed, if required in the jurisdiction where the Project is located. The Contractor shall designate in writing a representative who shall have express authority to bind the Contractor with respect to all matters under this Contract. The term "Contractor" means the Contractor or the Contractor's authorized representative.

§ 3.1.2 The Contractor shall perform the Work in accordance with the Contract Documents.

§ 3.1.3 The Contractor shall not be relieved of obligations to perform the Work in accordance with the Contract Documents either by activities or duties of the Architect in the Architect's administration of the Contract, or by tests, inspections or approvals required or performed by persons or entities other than the Contractor.

### § 3.2 REVIEW OF CONTRACT DOCUMENTS AND FIELD CONDITIONS BY CONTRACTOR

§ 3.2.1 Execution of the Contract by the Contractor is a representation that the Contractor has visited the site, become generally familiar with local conditions under which the Work is to be performed and correlated personal observations with requirements of the Contract Documents.

§ 3.2.2 Because the Contract Documents are complementary, the Contractor shall, before starting each portion of the Work, carefully study and compare the various Contract Documents relative to that portion of the Work, as well as the information furnished by the Owner pursuant to Section 2.2.3, shall take field measurements of any existing

Init.

AIA Document A201™ – 2007. Copyright © 1911, 1915, 1918, 1925, 1937, 1951, 1958, 1961, 1963, 1966, 1970, 1976, 1987, 1997 and 2007 by The American Institute of Architects. All rights reserved. **WARNING: This AIA® Document is protected by U.S. Copyright Law and International Treaties. Unauthorized reproduction or distribution of this AIA® Document, or any portion of it, may result in severe civil and criminal penalties, and will be prosecuted to the maximum extent possible under the law.** This document was produced by AIA software at 10:01:17 on 02/26/2018 under Order No 2737583500 which expires on 10/24/2018, and is not for resale.

User Notes:

conditions related to that portion of the Work, and shall observe any conditions at the site affecting it. These obligations are for the purpose of facilitating coordination and construction by the Contractor and are not for the purpose of discovering errors, omissions, or inconsistencies in the Contract Documents; however, the Contractor shall promptly report to the Architect any errors, inconsistencies or omissions discovered by or made known to the Contractor as a request for information in such form as the Architect may require. It is recognized that the Contractor's review is made in the Contractor's capacity as a contractor and not as a licensed design professional, unless otherwise specifically provided in the Contract Documents.

§ 3.2.3 The Contractor is not required to ascertain that the Contract Documents are in accordance with applicable laws, statutes, ordinances, codes, rules and regulations, or lawful orders of public authorities, but the Contractor shall promptly report to the Architect any nonconformity discovered by or made known to the Contractor as a request for information in such form as the Architect may require.

§ 3.2.4 If the Contractor believes that additional cost or time is involved because of clarifications or instructions the Architect issues in response to the Contractor's notices or requests for information pursuant to Sections 3.2.2 or 3.2.3, the Contractor shall make Claims as provided in Article 15. If the Contractor fails to perform the obligations of Sections 3.2.2 or 3.2.3, the Contractor shall pay such costs and damages to the Owner as would have been avoided if the Contractor had performed such obligations. If the Contractor performs those obligations, the Contractor shall not be liable to the Owner or Architect for damages resulting from errors, inconsistencies or omissions in the Contract Documents, for differences between field measurements or conditions and the Contract Documents, or for nonconformities of the Contract Documents to applicable laws, statutes, ordinances, codes, rules and regulations, and lawful orders of public authorities.

### § 3.3 SUPERVISION AND CONSTRUCTION PROCEDURES

§ 3.3.1 The Contractor shall supervise and direct the Work, using the Contractor's best skill and attention. The Contractor shall be solely responsible for, and have control over, construction means, methods, techniques, sequences and procedures and for coordinating all portions of the Work under the Contract, unless the Contract Documents give other specific instructions concerning these matters. If the Contract Documents give specific instructions concerning construction means, methods, techniques, sequences or procedures, the Contractor shall evaluate the jobsite safety thereof and, except as stated below, shall be fully and solely responsible for the jobsite safety of such means, methods, techniques, sequences or procedures. If the Contractor determines that such means, methods, techniques, sequences or procedures may not be safe, the Contractor shall give timely written notice to the Owner and Architect and shall not proceed with that portion of the Work without further written instructions from the Architect. If the Contractor is then instructed to proceed with the required means, methods, techniques, sequences or procedures without acceptance of changes proposed by the Contractor, the Owner shall be solely responsible for any loss or damage arising solely from those Owner-required means, methods, techniques, sequences or procedures.

§ 3.3.2 The Contractor shall be responsible to the Owner for acts and omissions of the Contractor's employees, Subcontractors and their agents and employees, and other persons or entities performing portions of the Work for, or on behalf of, the Contractor or any of its Subcontractors.

§ 3.3.3 The Contractor shall be responsible for inspection of portions of Work already performed to determine that such portions are in proper condition to receive subsequent Work.

### § 3.4 LABOR AND MATERIALS

§ 3.4.1 Unless otherwise provided in the Contract Documents, the Contractor shall provide and pay for labor, materials, equipment, tools, construction equipment and machinery, water, heat, utilities, transportation, and other facilities and services necessary for proper execution and completion of the Work, whether temporary or permanent and whether or not incorporated or to be incorporated in the Work.

§ 3.4.2 Except in the case of minor changes in the Work authorized by the Architect in accordance with Sections 3.12.8 or 7.4, the Contractor may make substitutions only with the consent of the Owner, after evaluation by the Architect and in accordance with a Change Order or Construction Change Directive.

§ 3.4.3 The Contractor shall enforce strict discipline and good order among the Contractor's employees and other persons carrying out the Work. The Contractor shall not permit employment of unfit persons or persons not properly

skilled in tasks assigned to them. Vendor warrants that all services will be performed to meet the requirements of the Agreement in an efficient and effective manner by trained and competent personnel.

### § 3.5 WARRANTY

The Contractor warrants to the Owner and Architect that materials and equipment furnished under the Contract will: (a) conform to the standards, specifications, drawings, samples or descriptions furnished by the City or by the Architect and agreed to by the City, including but not limited to all specifications attached as exhibits hereto; (b) be merchantable, of good quality and free from defects for a period of twelve months or longer, if so specified in writing, and fit and sufficient for the intended use; (c) comply with all federal, state and City laws, regulations and ordinances pertaining to delivery of supplies; (d) be of good title and free and clear of all liens and encumbrances; . Work, materials, or equipment not conforming to these requirements may be considered defective. The Contractor's warranty excludes remedy for damage or defect caused by abuse, alterations to the Work not executed by the Contractor, improper or insufficient maintenance, improper operation, or normal wear and tear and normal usage. If required by the Architect, the Contractor shall furnish satisfactory evidence as to the kind and quality of materials and equipment. Vendor agrees to reimburse the City for any losses, costs, damages or expenses, including without limitations, reasonable attorney's fees and expenses, arising from failure of the supplies to meet such warranties. To the extent that these terms conflict with the Supplemental Contract Provisions ¶13; A201-2007 will be the binding provisions on the issue of warranty.

Vendor shall insure that all manufacturers' warranties are transferred to the City and shall provide a copy of the warranty. These warranties shall be in addition to all other warranties, express, implied or statutory, and shall survive the City's payment, acceptance, inspection or failure to inspect the supplies.

### § 3.6 TAXES

The Contractor shall pay sales, consumer, use and similar taxes for the Work provided by the Contractor that are legally enacted when bids are received or negotiations concluded, whether or not yet effective or merely scheduled to go into effect. The City of Evanston is tax exempt and construction manager will submit sales tax exemption information prior to purchases to prevent sales tax from being assessed in the subject transaction.

### § 3.7 PERMITS, FEES, NOTICES AND COMPLIANCE WITH LAWS

§ 3.7.1 Unless otherwise provided in the Contract Documents, the Contractor shall secure and pay for (except for City of Evanston fees, as detailed below) the building permit as well as for other permits, fees, licenses, and inspections by government agencies necessary for proper execution and completion of the Work that are customarily secured after execution of the Contract and legally required at the time bids are received or negotiations concluded. All fees typically assessed by the City of Evanston for the construction of this project will be waived. This waiver does not apply to other government agencies.

§ 3.7.2 The Contractor shall comply with and give notices required by applicable laws, statutes, ordinances, codes, rules and regulations, and lawful orders of public authorities applicable to performance of the Work.

§ 3.7.3 If the Contractor performs Work knowing it to be contrary to applicable laws, statutes, ordinances, codes, rules and regulations, or lawful orders of public authorities, the Contractor shall assume appropriate responsibility for such Work and shall bear the costs attributable to correction.

§ 3.7.4 **Concealed or Unknown Conditions.** If the Contractor encounters conditions at the site that are (1) subsurface or otherwise concealed physical conditions that differ materially from those indicated in the Contract Documents or (2) unknown physical conditions of an unusual nature, that differ materially from those ordinarily found to exist and generally recognized as inherent in construction activities of the character provided for in the Contract Documents, the Contractor shall promptly provide notice to the Owner and the Architect before conditions are disturbed and in no event later than 21 days after first observance of the conditions. The Architect will promptly investigate such conditions and, if the Architect determines that they differ materially and cause an increase or decrease in the Contractor's cost of, or time required for, performance of any part of the Work, will recommend an equitable adjustment in the Contract Sum or Contract Time, or both. If the Architect determines that the conditions at the site are not materially different from those indicated in the Contract Documents and that no change in the terms of the Contract is justified, the Architect shall promptly notify the Owner and Contractor in writing, stating the reasons. If

Init.

either party disputes the Architect's determination or recommendation, that party may proceed as provided in Article 15.

§ 3.7.5 If, in the course of the Work, the Contractor encounters human remains or recognizes the existence of burial markers, archaeological sites or wetlands not indicated in the Contract Documents, the Contractor shall immediately suspend any operations that would affect them and shall notify the Owner and Architect. Upon receipt of such notice, the Owner shall promptly take any action necessary to obtain governmental authorization required to resume the operations. The Contractor shall continue to suspend such operations until otherwise instructed by the Owner but shall continue with all other operations that do not affect those remains or features. Requests for adjustments in the Contract Sum and Contract Time arising from the existence of such remains or features may be made as provided in Article 15.

### § 3.8 ALLOWANCES

§ 3.8.1 The Contractor shall include in the Contract Sum all allowances stated in the Contract Documents. Items covered by allowances shall be supplied for such amounts and by such persons or entities as the Owner may direct, but the Contractor shall not be required to employ persons or entities to whom the Contractor has reasonable objection.

§ 3.8.2 Unless otherwise provided in the Contract Documents,

- .1 Allowances shall cover the cost to the Contractor of materials and equipment delivered at the site and all required taxes, less applicable trade discounts;
- .2 Contractor's costs for unloading and handling at the site, labor, installation costs, overhead, profit and other expenses contemplated for stated allowance amounts shall be included in the Contract Sum but not in the allowances; and
- .3 Whenever costs are more than or less than allowances, the Contract Sum shall be adjusted accordingly by Change Order. The amount of the Change Order shall reflect (1) the difference between actual costs and the allowances under Section 3.8.2.1 and (2) changes in Contractor's costs under Section 3.8.2.2.

§ 3.8.3 Materials and equipment under an allowance shall be selected by the Owner with reasonable promptness.

### § 3.9 SUPERINTENDENT

§ 3.9.1 The Contractor shall employ a competent superintendent and necessary assistants who shall be in attendance at the Project site during performance of the Work. The superintendent shall represent the Contractor, and communications given to the superintendent shall be as binding as if given to the Contractor.

§ 3.9.2 The Contractor, as soon as practicable after award of the Contract, shall furnish in writing to the Owner through the Architect the name and qualifications of a proposed superintendent. The Architect may reply within 14 days to the Contractor in writing stating (1) whether the Owner or the Architect has reasonable objection to the proposed superintendent or (2) that the Architect requires additional time to review. Failure of the Architect to reply within the 14 day period shall constitute notice of no reasonable objection.

§ 3.9.3 The Contractor shall not employ a proposed superintendent to whom the Owner or Architect has made reasonable and timely objection. The Contractor shall not change the superintendent without the Owner's consent, which shall not unreasonably be withheld or delayed.

### § 3.10 CONTRACTOR'S CONSTRUCTION SCHEDULES

§ 3.10.1 The Contractor, promptly after being awarded the Contract, shall prepare and submit for the Owner's and Architect's information a Contractor's construction schedule for the Work. The schedule shall not exceed time limits current under the Contract Documents, shall be revised at appropriate intervals as required by the conditions of the Work and Project, shall be related to the entire Project to the extent required by the Contract Documents, and shall provide for expeditious and practicable execution of the Work.

§ 3.10.2 The Contractor shall prepare a submittal schedule, promptly after being awarded the Contract and thereafter as necessary to maintain a current submittal schedule, and shall submit the schedule(s) for the Architect's approval. The Architect's approval shall not unreasonably be delayed or withheld. The submittal schedule shall (1) be coordinated with the Contractor's construction schedule, and (2) allow the Architect reasonable time to review submittals. If the Contractor fails to submit a submittal schedule, the Contractor shall not be entitled to any increase in Contract Sum or extension of Contract Time based on the time required for review of submittals.

Init.

§ 3.10.3 The Contractor shall perform the Work in general accordance with the most recent schedules submitted to the Owner and Architect.

### § 3.11 DOCUMENTS AND SAMPLES AT THE SITE

The Contractor shall maintain at the site for the Owner one copy of the Drawings, Specifications, Addenda, Change Orders and other Modifications, in good order and marked currently to indicate field changes and selections made during construction, and one copy of approved Shop Drawings, Product Data, Samples and similar required submittals. These shall be available to the Architect and shall be delivered to the Architect for submittal to the Owner upon completion of the Work as a record of the Work as constructed.

### § 3.12 SHOP DRAWINGS, PRODUCT DATA AND SAMPLES

§ 3.12.1 Shop Drawings are drawings, diagrams, schedules and other data specially prepared for the Work by the Contractor or a Subcontractor, Sub-subcontractor, manufacturer, supplier or distributor to illustrate some portion of the Work.

§ 3.12.2 Product Data are illustrations, standard schedules, performance charts, instructions, brochures, diagrams and other information furnished by the Contractor to illustrate materials or equipment for some portion of the Work.

§ 3.12.3 Samples are physical examples that illustrate materials, equipment or workmanship and establish standards by which the Work will be judged.

§ 3.12.4 Shop Drawings, Product Data, Samples and similar submittals are not Contract Documents. Their purpose is to demonstrate the way by which the Contractor proposes to conform to the information given and the design concept expressed in the Contract Documents for those portions of the Work for which the Contract Documents require submittals. Review by the Architect is subject to the limitations of Section 4.2.7. Informational submittals upon which the Architect is not expected to take responsive action may be so identified in the Contract Documents. Submittals that are not required by the Contract Documents may be returned by the Architect without action.

§ 3.12.5 The Contractor shall review for compliance with the Contract Documents, approve and submit to the Architect Shop Drawings, Product Data, Samples and similar submittals required by the Contract Documents in accordance with the submittal schedule approved by the Architect or, in the absence of an approved submittal schedule, with reasonable promptness and in such sequence as to cause no delay in the Work or in the activities of the Owner or of separate contractors.

§ 3.12.6 By submitting Shop Drawings, Product Data, Samples and similar submittals, the Contractor represents to the Owner and Architect that the Contractor has (1) reviewed and approved them, (2) determined and verified materials, field measurements and field construction criteria related thereto, or will do so and (3) checked and coordinated the information contained within such submittals with the requirements of the Work and of the Contract Documents.

§ 3.12.7 The Contractor shall perform no portion of the Work for which the Contract Documents require submittal and review of Shop Drawings, Product Data, Samples or similar submittals until the respective submittal has been approved by the Architect.

§ 3.12.8 The Work shall be in accordance with approved submittals except that the Contractor shall not be relieved of responsibility for deviations from requirements of the Contract Documents by the Architect's approval of Shop Drawings, Product Data, Samples or similar submittals unless the Contractor has specifically informed the Architect in writing of such deviation at the time of submittal and (1) the Architect has given written approval to the specific deviation as a minor change in the Work, or (2) a Change Order or Construction Change Directive has been issued authorizing the deviation. The Contractor shall not be relieved of responsibility for errors or omissions in Shop Drawings, Product Data, Samples or similar submittals by the Architect's approval thereof.

§ 3.12.9 The Contractor shall direct specific attention, in writing or on resubmitted Shop Drawings, Product Data, Samples or similar submittals, to revisions other than those requested by the Architect on previous submittals. In the absence of such written notice, the Architect's approval of a resubmission shall not apply to such revisions.

§ 3.12.10 The Contractor shall not be required to provide professional services that constitute the practice of architecture or engineering unless such services are specifically required by the Contract Documents for a portion of

Init.

the Work or unless the Contractor needs to provide such services in order to carry out the Contractor's responsibilities for construction means, methods, techniques, sequences and procedures. The Contractor shall not be required to provide professional services in violation of applicable law. If professional design services or certifications by a design professional related to systems, materials or equipment are specifically required of the Contractor by the Contract Documents, the Owner and the Architect will specify all performance and design criteria that such services must satisfy. The Contractor shall cause such services or certifications to be provided by a properly licensed design professional, whose signature and seal shall appear on all drawings, calculations, specifications, certifications, Shop Drawings and other submittals prepared by such professional. Shop Drawings and other submittals related to the Work designed or certified by such professional, if prepared by others, shall bear such professional's written approval when submitted to the Architect. The Owner and the Architect shall be entitled to rely upon the adequacy, accuracy and completeness of the services, certifications and approvals performed or provided by such design professionals, provided the Owner and Architect have specified to the Contractor all performance and design criteria that such services must satisfy. Pursuant to this Section 3.12.10, the Architect will review, approve or take other appropriate action on submittals only for the limited purpose of checking for conformance with information given and the design concept expressed in the Contract Documents. The Contractor shall not be responsible for the adequacy of the performance and design criteria specified in the Contract Documents.

### § 3.13 USE OF SITE

The Contractor shall confine operations at the site to areas permitted by applicable laws, statutes, ordinances, codes, rules and regulations, and lawful orders of public authorities and the Contract Documents and shall not unreasonably encumber the site with materials or equipment.

### § 3.14 CUTTING AND PATCHING

§ 3.14.1 The Contractor shall be responsible for cutting, fitting or patching required to complete the Work or to make its parts fit together properly. All areas requiring cutting, fitting and patching shall be restored to the condition existing prior to the cutting, fitting and patching, unless otherwise required by the Contract Documents.

§ 3.14.2 The Contractor shall not damage or endanger a portion of the Work or fully or partially completed construction of the Owner or separate contractors by cutting, patching or otherwise altering such construction, or by excavation. The Contractor shall not cut or otherwise alter such construction by the Owner or a separate contractor except with written consent of the Owner and of such separate contractor; such consent shall not be unreasonably withheld. The Contractor shall not unreasonably withhold from the Owner or a separate contractor the Contractor's consent to cutting or otherwise altering the Work.

### § 3.15 CLEANING UP

§ 3.15.1 The Contractor shall keep the premises and surrounding area free from accumulation of waste materials or rubbish caused by operations under the Contract. At completion of the Work, the Contractor shall remove waste materials, rubbish, the Contractor's tools, construction equipment, machinery and surplus materials from and about the Project.

§ 3.15.2 If the Contractor fails to clean up as provided in the Contract Documents, the Owner may do so and Owner shall be entitled to reimbursement from the Contractor.

### § 3.16 ACCESS TO WORK

The Contractor shall provide the Owner and Architect access to the Work in preparation and progress wherever located.

### § 3.17 ROYALTIES, PATENTS AND COPYRIGHTS

The Contractor shall pay all royalties and license fees. The Contractor shall defend suits or claims for infringement of copyrights and patent rights and shall hold the Owner and Architect harmless from loss on account thereof, but shall not be responsible for such defense or loss when a particular design, process or product of a particular manufacturer or manufacturers is required by the Contract Documents, or where the copyright violations are contained in Drawings, Specifications or other documents prepared by the Owner or Architect. However, if the Contractor has reason to believe that the required design, process or product is an infringement of a copyright or a patent, the Contractor shall be responsible for such loss unless such information is promptly furnished to the Architect.

### § 3.18 INDEMNIFICATION

§ 3.18.1 To the fullest extent permitted by law the Contractor shall indemnify and hold harmless the Owner, Architect, Architect's consultants, and agents and employees of any of them from and against claims, damages, losses and expenses, including but not limited to attorneys' fees, arising out of or resulting from performance of the Work, provided that such claim, damage, loss or expense is attributable to bodily injury, sickness, disease or death, or to injury to or destruction of tangible property (other than the Work itself), but only to the extent caused by the negligent acts or omissions of the Contractor, a Subcontractor, anyone directly or indirectly employed by them or anyone for whose acts they may be liable, regardless of whether or not such claim, damage, loss or expense is caused in part by a party indemnified hereunder. Such obligation shall not be construed to negate, abridge, or reduce other rights or obligations of indemnity that would otherwise exist as to a party or person described in this Section 3.18.

§ 3.18.2 In claims against any person or entity indemnified under this Section 3.18 by an employee of the Contractor, a Subcontractor, anyone directly or indirectly employed by them or anyone for whose acts they may be liable, the indemnification obligation under Section 3.18.1 shall not be limited by a limitation on amount or type of damages, compensation or benefits payable by or for the Contractor or a Subcontractor under workers' compensation acts, disability benefit acts or other employee benefit acts.

## ARTICLE 4 ARCHITECT

### § 4.1 GENERAL

§ 4.1.1 The Owner shall retain an architect lawfully licensed to practice architecture or an entity lawfully practicing architecture in the jurisdiction where the Project is located. That person or entity is identified as the Architect in the Agreement and is referred to throughout the Contract Documents as if singular in number.

§ 4.1.2 Duties, responsibilities and limitations of authority of the Architect as set forth in the Contract Documents shall not be restricted, modified or extended without written consent of the Owner, Contractor and Architect. Consent shall not be unreasonably withheld.

§ 4.1.3 If the employment of the Architect is terminated, the Owner shall employ a successor architect as to whom the Contractor has no reasonable objection and whose status under the Contract Documents shall be that of the Architect.

### § 4.2 ADMINISTRATION OF THE CONTRACT

§ 4.2.1 The Architect will provide administration of the Contract as described in the Contract Documents and will be an Owner's representative during construction until the date the Architect issues the final Certificate for Payment. The Architect will have authority to act on behalf of the Owner only to the extent provided in the Contract Documents.

§ 4.2.2 The Architect will visit the site at intervals appropriate to the stage of construction, or as otherwise agreed with the Owner, to become generally familiar with the progress and quality of the portion of the Work completed, and to determine in general if the Work observed is being performed in a manner indicating that the Work, when fully completed, will be in accordance with the Contract Documents. However, the Architect will not be required to make exhaustive or continuous on-site inspections to check the quality or quantity of the Work. The Architect will not have control over, charge of, or responsibility for, the construction means, methods, techniques, sequences or procedures, or for the safety precautions and programs in connection with the Work, since these are solely the Contractor's rights and responsibilities under the Contract Documents, except as provided in Section 3.3.1.

§ 4.2.3 On the basis of the site visits, the Architect will keep the Owner reasonably informed about the progress and quality of the portion of the Work completed, and report to the Owner (1) known deviations from the Contract Documents and from the most recent construction schedule submitted by the Contractor, and (2) defects and deficiencies observed in the Work. The Architect will not be responsible for the Contractor's failure to perform the Work in accordance with the requirements of the Contract Documents. The Architect will not have control over or charge of and will not be responsible for acts or omissions of the Contractor, Subcontractors, or their agents or employees, or any other persons or entities performing portions of the Work.

### § 4.2.4 COMMUNICATIONS FACILITATING CONTRACT ADMINISTRATION

Except as otherwise provided in the Contract Documents or when direct communications have been specially authorized, the Owner and Contractor shall endeavor to communicate with each other through the Architect about matters arising out of or relating to the Contract. Communications by and with the Architect's consultants shall be

through the Architect. Communications by and with Subcontractors and material suppliers shall be through the Contractor. Communications by and with separate contractors shall be through the Owner.

§ 4.2.5 Based on the Architect's evaluations of the Contractor's Applications for Payment, the Architect will review and certify the amounts due the Contractor and will issue Certificates for Payment in such amounts.

§ 4.2.6 The Architect has authority to reject Work that does not conform to the Contract Documents. Whenever the Architect considers it necessary or advisable, the Architect will have authority to require inspection or testing of the Work in accordance with Sections 13.5.2 and 13.5.3, whether or not such Work is fabricated, installed or completed. However, neither this authority of the Architect nor a decision made in good faith either to exercise or not to exercise such authority shall give rise to a duty or responsibility of the Architect to the Contractor, Subcontractors, material and equipment suppliers, their agents or employees, or other persons or entities performing portions of the Work.

§ 4.2.7 The Architect will review and approve, or take other appropriate action upon, the Contractor's submittals such as Shop Drawings, Product Data and Samples, but only for the limited purpose of checking for conformance with information given and the design concept expressed in the Contract Documents. The Architect's action will be taken in accordance with the submittal schedule approved by the Architect or, in the absence of an approved submittal schedule, with reasonable promptness while allowing sufficient time in the Architect's professional judgment to permit adequate review. Review of such submittals is not conducted for the purpose of determining the accuracy and completeness of other details such as dimensions and quantities, or for substantiating instructions for installation or performance of equipment or systems, all of which remain the responsibility of the Contractor as required by the Contract Documents. The Architect's review of the Contractor's submittals shall not relieve the Contractor of the obligations under Sections 3.3, 3.5 and 3.12. The Architect's review shall not constitute approval of safety precautions or, unless otherwise specifically stated by the Architect, of any construction means, methods, techniques, sequences or procedures. The Architect's approval of a specific item shall not indicate approval of an assembly of which the item is a component.

§ 4.2.8 The Architect will prepare Change Orders and Construction Change Directives, and may authorize minor changes in the Work as provided in Section 7.4. The Architect will investigate and make determinations and recommendations regarding concealed and unknown conditions as provided in Section 3.7.4.

§ 4.2.9 The Architect will conduct inspections to determine the date or dates of Substantial Completion and the date of final completion; issue Certificates of Substantial Completion pursuant to Section 9.8; receive and forward to the Owner, for the Owner's review and records, written warranties and related documents required by the Contract and assembled by the Contractor pursuant to Section 9.10; and issue a final Certificate for Payment pursuant to Section 9.10.

§ 4.2.10 If the Owner and Architect agree, the Architect will provide one or more project representatives to assist in carrying out the Architect's responsibilities at the site. The duties, responsibilities and limitations of authority of such project representatives shall be as set forth in an exhibit to be incorporated in the Contract Documents.

§ 4.2.11 The Architect will interpret and decide matters concerning performance under, and requirements of, the Contract Documents on written request of either the Owner or Contractor. The Architect's response to such requests will be made in writing within any time limits agreed upon or otherwise with reasonable promptness.

§ 4.2.12 Interpretations and decisions of the Architect will be consistent with the intent of, and reasonably inferable from, the Contract Documents and will be in writing or in the form of drawings. When making such interpretations and decisions, the Architect will endeavor to secure faithful performance by both Owner and Contractor, will not show partiality to either and will not be liable for results of interpretations or decisions rendered in good faith.

§ 4.2.13 The Architect's decisions on matters relating to aesthetic effect will be final if consistent with the intent expressed in the Contract Documents.

§ 4.2.14 The Architect will review and respond to requests for information about the Contract Documents. The Architect's response to such requests will be made in writing within any time limits agreed upon or otherwise with reasonable promptness. If appropriate, the Architect will prepare and issue supplemental Drawings and Specifications in response to the requests for information.

Init.



## ARTICLE 5 SUBCONTRACTORS

### § 5.1 DEFINITIONS

§ 5.1.1 A Subcontractor is a person or entity who has a direct contract with the Contractor to perform a portion of the Work at the site. The term "Subcontractor" is referred to throughout the Contract Documents as if singular in number and means a Subcontractor or an authorized representative of the Subcontractor. The term "Subcontractor" does not include a separate contractor or subcontractors of a separate contractor.

§ 5.1.2 A Sub-subcontractor is a person or entity who has a direct or indirect contract with a Subcontractor to perform a portion of the Work at the site. The term "Sub-subcontractor" is referred to throughout the Contract Documents as if singular in number and means a Sub-subcontractor or an authorized representative of the Sub-subcontractor.

### § 5.2 AWARD OF SUBCONTRACTS AND OTHER CONTRACTS FOR PORTIONS OF THE WORK

§ 5.2.1 Unless otherwise stated in the Contract Documents or the bidding requirements, the Contractor, as soon as practicable after award of the Contract, shall furnish in writing to the Owner through the Architect the names of persons or entities (including those who are to furnish materials or equipment fabricated to a special design) proposed for each principal portion of the Work. The Architect may reply within 14 days to the Contractor in writing stating (1) whether the Owner or the Architect has reasonable objection to any such proposed person or entity or (2) that the Architect requires additional time for review. Failure of the Owner or Architect to reply within the 14-day period shall constitute notice of no reasonable objection.

§ 5.2.2 The Contractor shall not contract with a proposed person or entity to whom the Owner or Architect has made reasonable and timely objection. The Contractor shall not be required to contract with anyone to whom the Contractor has made reasonable objection.

§ 5.2.3 If the Owner or Architect has reasonable objection to a person or entity proposed by the Contractor, the Contractor shall propose another to whom the Owner or Architect has no reasonable objection. If the proposed but rejected Subcontractor was reasonably capable of performing the Work, the Contract Sum and Contract Time shall be increased or decreased by the difference, if any, occasioned by such change, and an appropriate Change Order shall be issued before commencement of the substitute Subcontractor's Work. However, no increase in the Contract Sum or Contract Time shall be allowed for such change unless the Contractor has acted promptly and responsively in submitting names as required.

§ 5.2.4 The Contractor shall not substitute a Subcontractor, person or entity previously selected if the Owner or Architect makes reasonable objection to such substitution.

### § 5.3 SUBCONTRACTUAL RELATIONS

By appropriate agreement, written where legally required for validity, the Contractor shall require each Subcontractor, to the extent of the Work to be performed by the Subcontractor, to be bound to the Contractor by terms of the Contract Documents, and to assume toward the Contractor all the obligations and responsibilities, including the responsibility for safety of the Subcontractor's Work, which the Contractor, by these Documents, assumes toward the Owner and Architect. Each subcontract agreement shall preserve and protect the rights of the Owner and Architect under the Contract Documents with respect to the Work to be performed by the Subcontractor so that subcontracting thereof will not prejudice such rights, and shall allow to the Subcontractor, unless specifically provided otherwise in the subcontract agreement, the benefit of all rights, remedies and redress against the Contractor that the Contractor, by the Contract Documents, has against the Owner. Where appropriate, the Contractor shall require each Subcontractor to enter into similar agreements with Sub-subcontractors. The Contractor shall make available to each proposed Subcontractor, prior to the execution of the subcontract agreement, copies of the Contract Documents to which the Subcontractor will be bound, and, upon written request of the Subcontractor, identify to the Subcontractor terms and conditions of the proposed subcontract agreement that may be at variance with the Contract Documents. Subcontractors will similarly make copies of applicable portions of such documents available to their respective proposed Sub-subcontractors.

### § 5.4 CONTINGENT ASSIGNMENT OF SUBCONTRACTS

§ 5.4.1 Each subcontract agreement for a portion of the Work is assigned by the Contractor to the Owner, provided that

- .1 assignment is effective only after termination of the Contract by the Owner for cause pursuant to Section 14.2 and only for those subcontract agreements that the Owner accepts by notifying the Subcontractor and Contractor in writing; and
- .2 assignment is subject to the prior rights of the surety, if any, obligated under bond relating to the Contract.

When the Owner accepts the assignment of a subcontract agreement, the Owner assumes the Contractor's rights and obligations under the subcontract.

§ 5.4.2 Upon such assignment, if the Work has been suspended for more than 30 days, the Subcontractor's compensation shall be equitably adjusted for increases in cost resulting from the suspension.

§ 5.4.3 Upon such assignment to the Owner under this Section 5.4, the Owner may further assign the subcontract to a successor contractor or other entity. If the Owner assigns the subcontract to a successor contractor or other entity, the Owner shall nevertheless remain legally responsible for all of the successor contractor's obligations under the subcontract.

## ARTICLE 6 CONSTRUCTION BY OWNER OR BY SEPARATE CONTRACTORS

### § 6.1 OWNER'S RIGHT TO PERFORM CONSTRUCTION AND TO AWARD SEPARATE CONTRACTS

§ 6.1.1 The Owner reserves the right to perform construction or operations related to the Project with the Owner's own forces, and to award separate contracts in connection with other portions of the Project or other construction or operations on the site under Conditions of the Contract identical or substantially similar to these including those portions related to insurance and waiver of subrogation. If the Contractor claims that delay or additional cost is involved because of such action by the Owner, the Contractor shall make such Claim as provided in Article 15.

§ 6.1.2 When separate contracts are awarded for different portions of the Project or other construction or operations on the site, the term "Contractor" in the Contract Documents in each case shall mean the Contractor who executes each separate Owner-Contractor Agreement.

§ 6.1.3 The Owner shall provide for coordination of the activities of the Owner's own forces and of each separate contractor with the Work of the Contractor, who shall cooperate with them. The Contractor shall participate with other separate contractors and the Owner in reviewing their construction schedules. The Contractor shall make any revisions to the construction schedule deemed necessary after a joint review and mutual agreement. The construction schedules shall then constitute the schedules to be used by the Contractor, separate contractors and the Owner until subsequently revised.

§ 6.1.4 Unless otherwise provided in the Contract Documents, when the Owner performs construction or operations related to the Project with the Owner's own forces, the Owner shall be deemed to be subject to the same obligations and to have the same rights that apply to the Contractor under the Conditions of the Contract, including, without excluding others, those stated in Article 3, this Article 6 and Articles 10, 11 and 12.

### § 6.2 MUTUAL RESPONSIBILITY

§ 6.2.1 The Contractor shall afford the Owner and separate contractors reasonable opportunity for introduction and storage of their materials and equipment and performance of their activities, and shall connect and coordinate the Contractor's construction and operations with theirs as required by the Contract Documents.

§ 6.2.2 If part of the Contractor's Work depends for proper execution or results upon construction or operations by the Owner or a separate contractor, the Contractor shall, prior to proceeding with that portion of the Work, promptly report to the Architect apparent discrepancies or defects in such other construction that would render it unsuitable for such proper execution and results. Failure of the Contractor so to report shall constitute an acknowledgment that the Owner's or separate contractor's completed or partially completed construction is fit and proper to receive the Contractor's Work, except as to defects not then reasonably discoverable.

§ 6.2.3 The Contractor shall reimburse the Owner for costs the Owner incurs that are payable to a separate contractor because of the Contractor's delays, improperly timed activities or defective construction. The Owner shall be responsible to the Contractor for costs the Contractor incurs because of a separate contractor's delays, improperly timed activities, damage to the Work or defective construction.

Init.

§ 6.2.4 The Contractor shall promptly remedy damage the Contractor wrongfully causes to completed or partially completed construction or to property of the Owner or separate contractors as provided in Section 10.2.5.

§ 6.2.5 The Owner and each separate contractor shall have the same responsibilities for cutting and patching as are described for the Contractor in Section 3.14.

### § 6.3 OWNER'S RIGHT TO CLEAN UP

If a dispute arises among the Contractor, separate contractors and the Owner as to the responsibility under their respective contracts for maintaining the premises and surrounding area free from waste materials and rubbish, the Owner may clean up and the Architect will allocate the cost among those responsible.

## ARTICLE 7 CHANGES IN THE WORK

### § 7.1 GENERAL

§ 7.1.1 Changes in the Work may be accomplished after execution of the Contract, and without invalidating the Contract, by Change Order, Construction Change Directive or order for a minor change in the Work, subject to the limitations stated in this Article 7 and elsewhere in the Contract Documents.

§ 7.1.2 A Change Order shall be based upon agreement among the Owner, Contractor and Architect; a Construction Change Directive requires agreement by the Owner and Architect and may or may not be agreed to by the Contractor; an order for a minor change in the Work may be issued by the Architect alone.

§ 7.1.3 Changes in the Work shall be performed under applicable provisions of the Contract Documents, and the Contractor shall proceed promptly, unless otherwise provided in the Change Order, Construction Change Directive or order for a minor change in the Work.

### § 7.2 CHANGE ORDERS

§ 7.2.1 A Change Order is a written instrument prepared by the Architect and signed by the Owner, Contractor and Architect stating their agreement upon all of the following:

- .1 The change in the Work;
- .2 The amount of the adjustment, if any, in the Contract Sum; and
- .3 The extent of the adjustment, if any, in the Contract Time.

### § 7.3 CONSTRUCTION CHANGE DIRECTIVES

§ 7.3.1 A Construction Change Directive is a written order prepared by the Architect and signed by the Owner and Architect, directing a change in the Work prior to agreement on adjustment, if any, in the Contract Sum or Contract Time, or both. The Owner may by Construction Change Directive, without invalidating the Contract, order changes in the Work within the general scope of the Contract consisting of additions, deletions or other revisions, the Contract Sum and Contract Time being adjusted accordingly.

§ 7.3.2 A Construction Change Directive shall be used in the absence of total agreement on the terms of a Change Order.

§ 7.3.3 If the Construction Change Directive provides for an adjustment to the Contract Sum, the adjustment shall be based on one of the following methods:

- .1 Mutual acceptance of a lump sum properly itemized and supported by sufficient substantiating data to permit evaluation;
- .2 Unit prices stated in the Contract Documents or subsequently agreed upon;
- .3 Cost to be determined in a manner agreed upon by the parties and a mutually acceptable fixed or percentage fee; or
- .4 As provided in Section 7.3.7.

§ 7.3.4 If unit prices are stated in the Contract Documents or subsequently agreed upon, and if quantities originally contemplated are materially changed in a proposed Change Order or Construction Change Directive so that application of such unit prices to quantities of Work proposed will cause substantial inequity to the Owner or Contractor, the applicable unit prices shall be equitably adjusted.

§ 7.3.5 Upon receipt of a Construction Change Directive, the Contractor shall promptly proceed with the change in the Work involved and advise the Architect of the Contractor's agreement or disagreement with the method, if any, provided in the Construction Change Directive for determining the proposed adjustment in the Contract Sum or Contract Time.

§ 7.3.6 A Construction Change Directive signed by the Contractor indicates the Contractor's agreement therewith, including adjustment in Contract Sum and Contract Time or the method for determining them. Such agreement shall be effective immediately and shall be recorded as a Change Order.

§ 7.3.7 If the Contractor does not respond promptly or disagrees with the method for adjustment in the Contract Sum, the Architect shall determine the method and the adjustment on the basis of reasonable expenditures and savings of those performing the Work attributable to the change, including, in case of an increase in the Contract Sum, an amount for overhead and profit as set forth in the Agreement, or if no such amount is set forth in the Agreement, a reasonable amount. In such case, and also under Section 7.3.3.3, the Contractor shall keep and present, in such form as the Architect may prescribe, an itemized accounting together with appropriate supporting data. Unless otherwise provided in the Contract Documents, costs for the purposes of this Section 7.3.7 shall be limited to the following:

- .1 Costs of labor, including social security, old age and unemployment insurance, fringe benefits required by agreement or custom, and workers' compensation insurance;
- .2 Costs of materials, supplies and equipment, including cost of transportation, whether incorporated or consumed;
- .3 Rental costs of machinery and equipment, exclusive of hand tools, whether rented from the Contractor or others;
- .4 Costs of premiums for all bonds and insurance, permit fees, and sales, use or similar taxes related to the Work; and
- .5 Additional costs of supervision and field office personnel directly attributable to the change.

§ 7.3.8 The amount of credit to be allowed by the Contractor to the Owner for a deletion or change that results in a net decrease in the Contract Sum shall be actual net cost as confirmed by the Architect. When both additions and credits covering related Work or substitutions are involved in a change, the allowance for overhead and profit shall be figured on the basis of net increase, if any, with respect to that change.

§ 7.3.9 Pending final determination of the total cost of a Construction Change Directive to the Owner, the Contractor may request payment for Work completed under the Construction Change Directive in Applications for Payment. The Architect will make an interim determination for purposes of monthly certification for payment for those costs and certify for payment the amount that the Architect determines, in the Architect's professional judgment, to be reasonably justified. The Architect's interim determination of cost shall adjust the Contract Sum on the same basis as a Change Order, subject to the right of either party to disagree and assert a Claim in accordance with Article 15.

§ 7.3.10 When the Owner and Contractor agree with a determination made by the Architect concerning the adjustments in the Contract Sum and Contract Time, or otherwise reach agreement upon the adjustments, such agreement shall be effective immediately and the Architect will prepare a Change Order. Change Orders may be issued for all or any part of a Construction Change Directive.

#### § 7.4 MINOR CHANGES IN THE WORK

The Architect has authority to order minor changes in the Work not involving adjustment in the Contract Sum or extension of the Contract Time and not inconsistent with the intent of the Contract Documents. Such changes will be effected by written order signed by the Architect and shall be binding on the Owner and Contractor.

### ARTICLE 8 TIME

#### § 8.1 DEFINITIONS

§ 8.1.1 Unless otherwise provided, Contract Time is the period of time, including authorized adjustments, allotted in the Contract Documents for Substantial Completion of the Work.

§ 8.1.2 The date of commencement of the Work is the date established in the Agreement.

§ 8.1.3 The date of Substantial Completion is the date certified by the Architect in accordance with Section 9.8.

§ 8.1.4 The term "day" as used in the Contract Documents shall mean calendar day unless otherwise specifically defined.

## § 8.2 PROGRESS AND COMPLETION

§ 8.2.1 Time limits stated in the Contract Documents are of the essence of the Contract. By executing the Agreement the Contractor confirms that the Contract Time is a reasonable period for performing the Work.

§ 8.2.2 The Contractor shall not knowingly, except by agreement or instruction of the Owner in writing, prematurely commence operations on the site or elsewhere prior to the effective date of insurance required by Article 11 to be furnished by the Contractor and Owner. The date of commencement of the Work shall not be changed by the effective date of such insurance.

§ 8.2.3 The Contractor shall proceed expeditiously with adequate forces and shall achieve Substantial Completion within the Contract Time.

## § 8.3 DELAYS AND EXTENSIONS OF TIME

§ 8.3.1 If the Contractor is delayed at any time in the commencement or progress of the Work by an act or neglect of the Owner or Architect, or of an employee of either, or of a separate contractor employed by the Owner; or by changes ordered in the Work; or by labor disputes, fire, unusual delay in deliveries, unavoidable casualties or other causes beyond the Contractor's control; or by delay authorized by the Owner pending mediation and arbitration; or by other causes that the Architect determines may justify delay, then the Contract Time shall be extended by Change Order for such reasonable time as the Architect may determine.

§ 8.3.2 Claims relating to time shall be made in accordance with applicable provisions of Article 15.

§ 8.3.3 This Section 8.3 does not preclude recovery of damages for delay by either party under other provisions of the Contract Documents.

## ARTICLE 9 PAYMENTS AND COMPLETION

### § 9.1 CONTRACT SUM

The Contract Sum is stated in the Agreement and, including authorized adjustments, is the total amount payable by the Owner to the Contractor for performance of the Work under the Contract Documents.

### § 9.2 SCHEDULE OF VALUES

Where the Contract is based on a stipulated sum or Guaranteed Maximum Price, the Contractor shall submit to the Architect, before the first Application for Payment, a schedule of values allocating the entire Contract Sum to the various portions of the Work and prepared in such form and supported by such data to substantiate its accuracy as the Architect may require. This schedule, unless objected to by the Architect, shall be used as a basis for reviewing the Contractor's Applications for Payment.

### § 9.3 APPLICATIONS FOR PAYMENT

§ 9.3.1 At least ten days before the date established for each progress payment, the Contractor shall submit to the Architect an itemized Application for Payment prepared in accordance with the schedule of values, if required under Section 9.2, for completed portions of the Work. Such application shall be notarized, if required, and supported by such data substantiating the Contractor's right to payment as the Owner or Architect may require, such as copies of requisitions from Subcontractors and material suppliers, and shall reflect retainage if provided for in the Contract Documents.

§ 9.3.1.1 As provided in Section 7.3.9, such applications may include requests for payment on account of changes in the Work that have been properly authorized by Construction Change Directives, or by interim determinations of the Architect, but not yet included in Change Orders.

§ 9.3.1.2 Applications for Payment shall not include requests for payment for portions of the Work for which the Contractor does not intend to pay a Subcontractor or material supplier, unless such Work has been performed by others whom the Contractor intends to pay.

§ 9.3.2 Unless otherwise provided in the Contract Documents, payments shall be made on account of materials and equipment delivered and suitably stored at the site for subsequent incorporation in the Work. If approved in advance by the Owner, payment may similarly be made for materials and equipment suitably stored off the site at a location agreed upon in writing. Payment for materials and equipment stored on or off the site shall be conditioned upon compliance by the Contractor with procedures satisfactory to the Owner to establish the Owner's title to such materials and equipment or otherwise protect the Owner's interest, and shall include the costs of applicable insurance, storage and transportation to the site for such materials and equipment stored off the site.

§ 9.3.3 The Contractor warrants that title to all Work covered by an Application for Payment will pass to the Owner no later than the time of payment. The Contractor further warrants that upon submittal of an Application for Payment all Work for which Certificates for Payment have been previously issued and payments received from the Owner shall, to the best of the Contractor's knowledge, information and belief, be free and clear of liens, claims, security interests or encumbrances in favor of the Contractor, Subcontractors, material suppliers, or other persons or entities making a claim by reason of having provided labor, materials and equipment relating to the Work.

#### § 9.4 CERTIFICATES FOR PAYMENT

§ 9.4.1 The Architect will, within seven days after receipt of the Contractor's Application for Payment, either issue to the Owner a Certificate for Payment, with a copy to the Contractor, for such amount as the Architect determines is properly due, or notify the Contractor and Owner in writing of the Architect's reasons for withholding certification in whole or in part as provided in Section 9.5.1.

§ 9.4.2 The issuance of a Certificate for Payment will constitute a representation by the Architect to the Owner, based on the Architect's evaluation of the Work and the data comprising the Application for Payment, that, to the best of the Architect's knowledge, information and belief, the Work has progressed to the point indicated and that the quality of the Work is in accordance with the Contract Documents. The foregoing representations are subject to an evaluation of the Work for conformance with the Contract Documents upon Substantial Completion, to results of subsequent tests and inspections, to correction of minor deviations from the Contract Documents prior to completion and to specific qualifications expressed by the Architect. The issuance of a Certificate for Payment will further constitute a representation that the Contractor is entitled to payment in the amount certified. However, the issuance of a Certificate for Payment will not be a representation that the Architect has (1) made exhaustive or continuous on-site inspections to check the quality or quantity of the Work, (2) reviewed construction means, methods, techniques, sequences or procedures, (3) reviewed copies of requisitions received from Subcontractors and material suppliers and other data requested by the Owner to substantiate the Contractor's right to payment, or (4) made examination to ascertain how or for what purpose the Contractor has used money previously paid on account of the Contract Sum.

#### § 9.5 DECISIONS TO WITHHOLD CERTIFICATION

§ 9.5.1 The Architect may withhold a Certificate for Payment in whole or in part, to the extent reasonably necessary to protect the Owner, if in the Architect's opinion the representations to the Owner required by Section 9.4.2 cannot be made. If the Architect is unable to certify payment in the amount of the Application, the Architect will notify the Contractor and Owner as provided in Section 9.4.1. If the Contractor and Architect cannot agree on a revised amount, the Architect will promptly issue a Certificate for Payment for the amount for which the Architect is able to make such representations to the Owner. The Architect may also withhold a Certificate for Payment or, because of subsequently discovered evidence, may nullify the whole or a part of a Certificate for Payment previously issued, to such extent as may be necessary in the Architect's opinion to protect the Owner from loss for which the Contractor is responsible, including loss resulting from acts and omissions described in Section 3.3.2, because of

- .1 defective Work not remedied;
- .2 third party claims filed or reasonable evidence indicating probable filing of such claims unless security acceptable to the Owner is provided by the Contractor;
- .3 failure of the Contractor to make payments properly to Subcontractors or for labor, materials or equipment;
- .4 reasonable evidence that the Work cannot be completed for the unpaid balance of the Contract Sum;
- .5 damage to the Owner or a separate contractor;
- .6 reasonable evidence that the Work will not be completed within the Contract Time, and that the unpaid balance would not be adequate to cover actual or liquidated damages for the anticipated delay; or
- .7 repeated failure to carry out the Work in accordance with the Contract Documents.

§ 9.5.2 When the above reasons for withholding certification are removed, certification will be made for amounts previously withheld.

§ 9.5.3 If the Architect withholds certification for payment under Section 9.5.1.3, the Owner may, at its sole option, issue joint checks to the Contractor and to any Subcontractor or material or equipment suppliers to whom the Contractor failed to make payment for Work properly performed or material or equipment suitably delivered. If the Owner makes payments by joint check, the Owner shall notify the Architect and the Architect will reflect such payment on the next Certificate for Payment.

## § 9.6 PROGRESS PAYMENTS

§ 9.6.1 After the Architect has issued a Certificate for Payment, the Owner shall make payment in the manner and within the time provided in the Contract Documents, and shall so notify the Architect.

§ 9.6.2 The Contractor shall pay each Subcontractor no later than seven days after receipt of payment from the Owner the amount to which the Subcontractor is entitled, reflecting percentages actually retained from payments to the Contractor on account of the Subcontractor's portion of the Work. The Contractor shall, by appropriate agreement with each Subcontractor, require each Subcontractor to make payments to Sub-subcontractors in a similar manner.

§ 9.6.3 The Architect will, on request, furnish to a Subcontractor, if practicable, information regarding percentages of completion or amounts applied for by the Contractor and action taken thereon by the Architect and Owner on account of portions of the Work done by such Subcontractor.

§ 9.6.4 The Owner has the right to request written evidence from the Contractor that the Contractor has properly paid Subcontractors and material and equipment suppliers amounts paid by the Owner to the Contractor for subcontracted Work. If the Contractor fails to furnish such evidence within seven days, the Owner shall have the right to contact Subcontractors to ascertain whether they have been properly paid. Neither the Owner nor Architect shall have an obligation to pay or to see to the payment of money to a Subcontractor, except as may otherwise be required by law.

§ 9.6.5 Contractor payments to material and equipment suppliers shall be treated in a manner similar to that provided in Sections 9.6.2, 9.6.3 and 9.6.4.

§ 9.6.6 A Certificate for Payment, a progress payment, or partial or entire use or occupancy of the Project by the Owner shall not constitute acceptance of Work not in accordance with the Contract Documents.

§ 9.6.7 Unless the Contractor provides the Owner with a payment bond in the full penal sum of the Contract Sum, payments received by the Contractor for Work properly performed by Subcontractors and suppliers shall be held by the Contractor for those Subcontractors or suppliers who performed Work or furnished materials, or both, under contract with the Contractor for which payment was made by the Owner. Nothing contained herein shall require money to be placed in a separate account and not commingled with money of the Contractor, shall create any fiduciary liability or tort liability on the part of the Contractor for breach of trust or shall entitle any person or entity to an award of punitive damages against the Contractor for breach of the requirements of this provision.

## § 9.7 FAILURE OF PAYMENT

If the Architect does not issue a Certificate for Payment, through no fault of the Contractor, within seven days after receipt of the Contractor's Application for Payment, or if the Owner does not pay the Contractor within seven days after the date established in the Contract Documents the amount certified by the Architect or awarded by binding dispute resolution, then the Contractor may, upon seven additional days' written notice to the Owner and Architect, stop the Work until payment of the amount owing has been received. The Contract Time shall be extended appropriately and the Contract Sum shall be increased by the amount of the Contractor's reasonable costs of shut-down, delay and start-up, plus interest as provided for in the Contract Documents.

## § 9.8 SUBSTANTIAL COMPLETION

§ 9.8.1 Substantial Completion is the stage in the progress of the Work when the Work or designated portion thereof is sufficiently complete in accordance with the Contract Documents so that the Owner can occupy or utilize the Work for its intended use.

§ 9.8.2 When the Contractor considers that the Work, or a portion thereof which the Owner agrees to accept separately, is substantially complete, the Contractor shall prepare and submit to the Architect a comprehensive list of items to be completed or corrected prior to final payment. Failure to include an item on such list does not alter the responsibility of the Contractor to complete all Work in accordance with the Contract Documents.

§ 9.8.3 Upon receipt of the Contractor's list, the Architect will make an inspection to determine whether the Work or designated portion thereof is substantially complete. If the Architect's inspection discloses any item, whether or not included on the Contractor's list, which is not sufficiently complete in accordance with the Contract Documents so that the Owner can occupy or utilize the Work or designated portion thereof for its intended use, the Contractor shall, before issuance of the Certificate of Substantial Completion, complete or correct such item upon notification by the Architect. In such case, the Contractor shall then submit a request for another inspection by the Architect to determine Substantial Completion.

§ 9.8.4 When the Work or designated portion thereof is substantially complete, the Architect will prepare a Certificate of Substantial Completion that shall establish the date of Substantial Completion, shall establish responsibilities of the Owner and Contractor for security, maintenance, heat, utilities, damage to the Work and insurance, and shall fix the time within which the Contractor shall finish all items on the list accompanying the Certificate. Warranties required by the Contract Documents shall commence on the date of Substantial Completion of the Work or designated portion thereof unless otherwise provided in the Certificate of Substantial Completion.

§ 9.8.5 The Certificate of Substantial Completion shall be submitted to the Owner and Contractor for their written acceptance of responsibilities assigned to them in such Certificate. Upon such acceptance and consent of surety, if any, the Owner shall make payment of retainage applying to such Work or designated portion thereof. Such payment shall be adjusted for Work that is incomplete or not in accordance with the requirements of the Contract Documents.

#### § 9.9 PARTIAL OCCUPANCY OR USE

§ 9.9.1 The Owner may occupy or use any completed or partially completed portion of the Work at any stage when such portion is designated by separate agreement with the Contractor, provided such occupancy or use is consented to by the insurer as required under Section 11.3.1.5 and authorized by public authorities having jurisdiction over the Project. Such partial occupancy or use may commence whether or not the portion is substantially complete, provided the Owner and Contractor have accepted in writing the responsibilities assigned to each of them for payments, retainage, if any, security, maintenance, heat, utilities, damage to the Work and insurance, and have agreed in writing concerning the period for correction of the Work and commencement of warranties required by the Contract Documents. When the Contractor considers a portion substantially complete, the Contractor shall prepare and submit a list to the Architect as provided under Section 9.8.2. Consent of the Contractor to partial occupancy or use shall not be unreasonably withheld. The stage of the progress of the Work shall be determined by written agreement between the Owner and Contractor or, if no agreement is reached, by decision of the Architect.

§ 9.9.2 Immediately prior to such partial occupancy or use, the Owner, Contractor and Architect shall jointly inspect the area to be occupied or portion of the Work to be used in order to determine and record the condition of the Work.

§ 9.9.3 Unless otherwise agreed upon, partial occupancy or use of a portion or portions of the Work shall not constitute acceptance of Work not complying with the requirements of the Contract Documents.

#### § 9.10 FINAL COMPLETION AND FINAL PAYMENT

§ 9.10.1 Upon receipt of the Contractor's written notice that the Work is ready for final inspection and acceptance and upon receipt of a final Application for Payment, the Architect will promptly make such inspection and, when the Architect finds the Work acceptable under the Contract Documents and the Contract fully performed, the Architect will promptly issue a final Certificate for Payment stating that to the best of the Architect's knowledge, information and belief, and on the basis of the Architect's on-site visits and inspections, the Work has been completed in accordance with terms and conditions of the Contract Documents and that the entire balance found to be due the Contractor and noted in the final Certificate is due and payable. The Architect's final Certificate for Payment will constitute a further representation that conditions listed in Section 9.10.2 as precedent to the Contractor's being entitled to final payment have been fulfilled.

§ 9.10.2 Neither final payment nor any remaining retained percentage shall become due until the Contractor submits to the Architect (1) an affidavit that payrolls, bills for materials and equipment, and other indebtedness connected with

Init.



the Work for which the Owner or the Owner's property might be responsible or encumbered (less amounts withheld by Owner) have been paid or otherwise satisfied, (2) a certificate evidencing that insurance required by the Contract Documents to remain in force after final payment is currently in effect and will not be canceled or allowed to expire until at least 30 days' prior written notice has been given to the Owner, (3) a written statement that the Contractor knows of no substantial reason that the insurance will not be renewable to cover the period required by the Contract Documents, (4) consent of surety, if any, to final payment and (5), if required by the Owner, other data establishing payment or satisfaction of obligations, such as receipts, releases and waivers of liens, claims, security interests or encumbrances arising out of the Contract, to the extent and in such form as may be designated by the Owner. If a Subcontractor refuses to furnish a release or waiver required by the Owner, the Contractor may furnish a bond satisfactory to the Owner to indemnify the Owner against such lien. If such lien remains unsatisfied after payments are made, the Contractor shall refund to the Owner all money that the Owner may be compelled to pay in discharging such lien, including all costs and reasonable attorneys' fees.

§ 9.10.3 If, after Substantial Completion of the Work, final completion thereof is materially delayed through no fault of the Contractor or by issuance of Change Orders affecting final completion, and the Architect so confirms, the Owner shall, upon application by the Contractor and certification by the Architect, and without terminating the Contract, make payment of the balance due for that portion of the Work fully completed and accepted. If the remaining balance for Work not fully completed or corrected is less than retainage stipulated in the Contract Documents, and if bonds have been furnished, the written consent of surety to payment of the balance due for that portion of the Work fully completed and accepted shall be submitted by the Contractor to the Architect prior to certification of such payment. Such payment shall be made under terms and conditions governing final payment, except that it shall not constitute a waiver of claims.

§ 9.10.4 The making of final payment shall constitute a waiver of Claims by the Owner except those arising from

- .1 liens, Claims, security interests or encumbrances arising out of the Contract and unsettled;
- .2 failure of the Work to comply with the requirements of the Contract Documents; or
- .3 terms of special warranties required by the Contract Documents.

§ 9.10.5 Acceptance of final payment by the Contractor, a Subcontractor or material supplier shall constitute a waiver of claims by that payee except those previously made in writing and identified by that payee as unsettled at the time of final Application for Payment.

## ARTICLE 10 PROTECTION OF PERSONS AND PROPERTY

### § 10.1 SAFETY PRECAUTIONS AND PROGRAMS

The Contractor shall be responsible for initiating, maintaining and supervising all safety precautions and programs in connection with the performance of the Contract.

### § 10.2 SAFETY OF PERSONS AND PROPERTY

§ 10.2.1 The Contractor shall take reasonable precautions for safety of, and shall provide reasonable protection to prevent damage, injury or loss to

- .1 employees on the Work and other persons who may be affected thereby;
- .2 the Work and materials and equipment to be incorporated therein, whether in storage on or off the site, under care, custody or control of the Contractor or the Contractor's Subcontractors or Sub-subcontractors; and
- .3 other property at the site or adjacent thereto, such as trees, shrubs, lawns, walks, pavements, roadways, structures and utilities not designated for removal, relocation or replacement in the course of construction.

§ 10.2.2 The Contractor shall comply with and give notices required by applicable laws, statutes, ordinances, codes, rules and regulations, and lawful orders of public authorities bearing on safety of persons or property or their protection from damage, injury or loss.

§ 10.2.3 The Contractor shall erect and maintain, as required by existing conditions and performance of the Contract, reasonable safeguards for safety and protection, including posting danger signs and other warnings against hazards, promulgating safety regulations and notifying owners and users of adjacent sites and utilities.

§ 10.2.4 When use or storage of explosives or other hazardous materials or equipment or unusual methods are necessary for execution of the Work, the Contractor shall exercise utmost care and carry on such activities under supervision of properly qualified personnel.

§ 10.2.5 The Contractor shall promptly remedy damage and loss (other than damage or loss insured under property insurance required by the Contract Documents) to property referred to in Sections 10.2.1.2 and 10.2.1.3 caused in whole or in part by the Contractor, a Subcontractor, a Sub-subcontractor, or anyone directly or indirectly employed by any of them, or by anyone for whose acts they may be liable and for which the Contractor is responsible under Sections 10.2.1.2 and 10.2.1.3, except damage or loss attributable to acts or omissions of the Owner or Architect or anyone directly or indirectly employed by either of them, or by anyone for whose acts either of them may be liable, and not attributable to the fault or negligence of the Contractor. The foregoing obligations of the Contractor are in addition to the Contractor's obligations under Section 3.18.

§ 10.2.6 The Contractor shall designate a responsible member of the Contractor's organization at the site whose duty shall be the prevention of accidents. This person shall be the Contractor's superintendent unless otherwise designated by the Contractor in writing to the Owner and Architect.

§ 10.2.7 The Contractor shall not permit any part of the construction or site to be loaded so as to cause damage or create an unsafe condition.

#### § 10.2.8 INJURY OR DAMAGE TO PERSON OR PROPERTY

If either party suffers injury or damage to person or property because of an act or omission of the other party, or of others for whose acts such party is legally responsible, written notice of such injury or damage, whether or not insured, shall be given to the other party within a reasonable time not exceeding 21 days after discovery. The notice shall provide sufficient detail to enable the other party to investigate the matter.

#### § 10.3 HAZARDOUS MATERIALS

§ 10.3.1 The Contractor is responsible for compliance with any requirements included in the Contract Documents regarding hazardous materials. If the Contractor encounters a hazardous material or substance not addressed in the Contract Documents and if reasonable precautions will be inadequate to prevent foreseeable bodily injury or death to persons resulting from a material or substance, including but not limited to asbestos or polychlorinated biphenyl (PCB), encountered on the site by the Contractor, the Contractor shall, upon recognizing the condition, immediately stop Work in the affected area and report the condition to the Owner and Architect in writing.

§ 10.3.2 Upon receipt of the Contractor's written notice, the Owner shall obtain the services of a licensed laboratory to verify the presence or absence of the material or substance reported by the Contractor and, in the event such material or substance is found to be present, to cause it to be rendered harmless. Unless otherwise required by the Contract Documents, the Owner shall furnish in writing to the Contractor and Architect the names and qualifications of persons or entities who are to perform tests verifying the presence or absence of such material or substance or who are to perform the task of removal or safe containment of such material or substance. The Contractor and the Architect will promptly reply to the Owner in writing stating whether or not either has reasonable objection to the persons or entities proposed by the Owner. If either the Contractor or Architect has an objection to a person or entity proposed by the Owner, the Owner shall propose another to whom the Contractor and the Architect have no reasonable objection. When the material or substance has been rendered harmless, Work in the affected area shall resume upon written agreement of the Owner and Contractor. By Change Order, the Contract Time shall be extended appropriately and the Contract Sum shall be increased in the amount of the Contractor's reasonable additional costs of shut-down, delay and start-up.

§ 10.3.3 To the fullest extent permitted by law, the Owner shall indemnify and hold harmless the Contractor, Subcontractors, Architect, Architect's consultants and agents and employees of any of them from and against claims, damages, losses and expenses, including but not limited to attorneys' fees, arising out of or resulting from performance of the Work in the affected area if in fact the material or substance presents the risk of bodily injury or death as described in Section 10.3.1 and has not been rendered harmless, provided that such claim, damage, loss or expense is attributable to bodily injury, sickness, disease or death, or to injury to or destruction of tangible property (other than the Work itself), except to the extent that such damage, loss or expense is due to the fault or negligence of the party seeking indemnity.

Init.

§ 10.3.4 The Owner shall not be responsible under this Section 10.3 for materials or substances the Contractor brings to the site unless such materials or substances are required by the Contract Documents. The Owner shall be responsible for materials or substances required by the Contract Documents, except to the extent of the Contractor's fault or negligence in the use and handling of such materials or substances.

§ 10.3.5 The Contractor shall indemnify the Owner for the cost and expense the Owner incurs (1) for remediation of a material or substance the Contractor brings to the site and negligently handles, or (2) where the Contractor fails to perform its obligations under Section 10.3.1, except to the extent that the cost and expense are due to the Owner's fault or negligence.

§ 10.3.6 If, without negligence on the part of the Contractor, the Contractor is held liable by a government agency for the cost of remediation of a hazardous material or substance solely by reason of performing Work as required by the Contract Documents, the Owner shall indemnify the Contractor for all cost and expense thereby incurred.

#### § 10.4 EMERGENCIES

In an emergency affecting safety of persons or property, the Contractor shall act, at the Contractor's discretion, to prevent threatened damage, injury or loss. Additional compensation or extension of time claimed by the Contractor on account of an emergency shall be determined as provided in Article 15 and Article 7.

### ARTICLE 11 INSURANCE AND BONDS

#### § 11.1 CONTRACTOR'S LIABILITY INSURANCE

§ 11.1.1 The Contractor shall purchase from and maintain in a company or companies lawfully authorized to do business in the jurisdiction in which the Project is located such insurance as will protect the Contractor from claims set forth below which may arise out of or result from the Contractor's operations and completed operations under the Contract and for which the Contractor may be legally liable, whether such operations be by the Contractor or by a Subcontractor or by anyone directly or indirectly employed by any of them, or by anyone for whose acts any of them may be liable:

- .1 Claims under workers' compensation, disability benefit and other similar employee benefit acts that are applicable to the Work to be performed;
- .2 Claims for damages because of bodily injury, occupational sickness or disease, or death of the Contractor's employees;
- .3 Claims for damages because of bodily injury, sickness or disease, or death of any person other than the Contractor's employees;
- .4 Claims for damages insured by usual personal injury liability coverage;
- .5 Claims for damages, other than to the Work itself, because of injury to or destruction of tangible property, including loss of use resulting therefrom;
- .6 Claims for damages because of bodily injury, death of a person or property damage arising out of ownership, maintenance or use of a motor vehicle;
- .7 Claims for bodily injury or property damage arising out of completed operations; and
- .8 Claims involving contractual liability insurance applicable to the Contractor's obligations under Section 3.18.

§ 11.1.2 The insurance required by Section 11.1.1 shall be written for not less than limits of liability specified in the Contract Documents or required by law, whichever coverage is greater. Coverages, whether written on an occurrence or claims-made basis, shall be maintained without interruption from the date of commencement of the Work until the date of final payment and termination of any coverage required to be maintained after final payment, and, with respect to the Contractor's completed operations coverage, until the expiration of the period for correction of Work or for such other period for maintenance of completed operations coverage as specified in the Contract Documents.

§ 11.1.3 Certificates of insurance acceptable to the Owner shall be filed with the Owner prior to commencement of the Work and thereafter upon renewal or replacement of each required policy of insurance. These certificates and the insurance policies required by this Section 11.1 shall contain a provision that coverages afforded under the policies will not be canceled or allowed to expire until at least 30 days' prior written notice has been given to the Owner. An additional certificate evidencing continuation of liability coverage, including coverage for completed operations, shall be submitted with the final Application for Payment as required by Section 9.10.2 and thereafter upon renewal or replacement of such coverage until the expiration of the time required by Section 11.1.2. Information concerning

reduction of coverage on account of revised limits or claims paid under the General Aggregate, or both, shall be furnished by the Contractor with reasonable promptness.

§ 11.1.4 The Contractor shall cause the commercial liability coverage required by the Contract Documents to include (1) the Owner, the Architect and the Architect's consultants as additional insureds for claims caused in whole or in part by the Contractor's negligent acts or omissions during the Contractor's operations; and (2) the Owner as an additional insured for claims caused in whole or in part by the Contractor's negligent acts or omissions during the Contractor's completed operations.

#### § 11.2 OWNER'S LIABILITY INSURANCE

The Owner shall be responsible for purchasing and maintaining the Owner's usual liability insurance.

#### § 11.3 PROPERTY INSURANCE

§ 11.3.1 Unless otherwise provided, the Owner shall purchase and maintain, in a company or companies lawfully authorized to do business in the jurisdiction in which the Project is located, property insurance written on a builder's risk "all-risk" or equivalent policy form in the amount of the initial Contract Sum, plus value of subsequent Contract Modifications and cost of materials supplied or installed by others, comprising total value for the entire Project at the site on a replacement cost basis without optional deductibles. Such property insurance shall be maintained, unless otherwise provided in the Contract Documents or otherwise agreed in writing by all persons and entities who are beneficiaries of such insurance, until final payment has been made as provided in Section 9.10 or until no person or entity other than the Owner has an insurable interest in the property required by this Section 11.3 to be covered, whichever is later. This insurance shall include interests of the Owner, the Contractor, Subcontractors and Sub-subcontractors in the Project.

§ 11.3.1.1 Property insurance shall be on an "all-risk" or equivalent policy form and shall include, without limitation, insurance against the perils of fire (with extended coverage) and physical loss or damage including, without duplication of coverage, theft, vandalism, malicious mischief, collapse, earthquake, flood, windstorm, falsework, testing and startup, temporary buildings and debris removal including demolition occasioned by enforcement of any applicable legal requirements, and shall cover reasonable compensation for Architect's and Contractor's services and expenses required as a result of such insured loss.

§ 11.3.1.2 If the Owner does not intend to purchase such property insurance required by the Contract and with all of the coverages in the amount described above, the Owner shall so inform the Contractor in writing prior to commencement of the Work. The Contractor may then effect insurance that will protect the interests of the Contractor, Subcontractors and Sub-subcontractors in the Work, and by appropriate Change Order the cost thereof shall be charged to the Owner. If the Contractor is damaged by the failure or neglect of the Owner to purchase or maintain insurance as described above, without so notifying the Contractor in writing, then the Owner shall bear all reasonable costs properly attributable thereto.

§ 11.3.1.3 If the property insurance requires deductibles, the Owner shall pay costs not covered because of such deductibles.

§ 11.3.1.4 This property insurance shall cover portions of the Work stored off the site, and also portions of the Work in transit.

§ 11.3.1.5 Partial occupancy or use in accordance with Section 9.9 shall not commence until the insurance company or companies providing property insurance have consented to such partial occupancy or use by endorsement or otherwise. The Owner and the Contractor shall take reasonable steps to obtain consent of the insurance company or companies and shall, without mutual written consent, take no action with respect to partial occupancy or use that would cause cancellation, lapse or reduction of insurance.

#### § 11.3.2 BOILER AND MACHINERY INSURANCE

The Owner shall purchase and maintain boiler and machinery insurance required by the Contract Documents or by law, which shall specifically cover such insured objects during installation and until final acceptance by the Owner; this insurance shall include interests of the Owner, Contractor, Subcontractors and Sub-subcontractors in the Work, and the Owner and Contractor shall be named insureds.

Init.

### § 11.3.3 LOSS OF USE INSURANCE

The Owner, at the Owner's option, may purchase and maintain such insurance as will insure the Owner against loss of use of the Owner's property due to fire or other hazards, however caused. The Owner waives all rights of action against the Contractor for loss of use of the Owner's property, including consequential losses due to fire or other hazards however caused.

§ 11.3.4 If the Contractor requests in writing that insurance for risks other than those described herein or other special causes of loss be included in the property insurance policy, the Owner shall, if possible, include such insurance, and the cost thereof shall be charged to the Contractor by appropriate Change Order.

*(Paragraph deleted)*

§ 11.3.6 Before an exposure to loss may occur, the Owner shall file with the Contractor a copy of each policy that includes insurance coverages required by this Section 11.3. Each policy shall contain all generally applicable conditions, definitions, exclusions and endorsements related to this Project. Each policy shall contain a provision that the policy will not be canceled or allowed to expire, and that its limits will not be reduced, until at least 30 days' prior written notice has been given to the Contractor.

*(Paragraphs deleted)*

### § 11.4 PERFORMANCE BOND AND PAYMENT BOND

- A. § 11.4.1 The Owner shall have the right to require the Contractor to furnish bonds covering faithful performance of the Contract and payment of obligations arising thereunder as stipulated in bidding requirements or specifically required in the Contract Documents on the date of execution of the Contract. The Construction Manager shall, within ten (10) calendar days after acceptance of the bid by the City, furnish a performance bond for 110% of the full amount of the contract from insurance companies having not less than A Policyholders Rating from the most recent Alfred M. Best and Co., Inc. listing available. Certification of the insurance company's rating shall be provided prior to contract implementation and quarterly thereafter until contract completion. Should such rating fall below the required A+ level during performance of the contract, it will be the contractor's responsibility to notify the City and provide a new bond from an insurance company whose rating meets the City's requirements.

§ 11.4.2 Upon the request of any person or entity appearing to be a potential beneficiary of bonds covering payment of obligations arising under the Contract, the Contractor shall promptly furnish a copy of the bonds or shall authorize a copy to be furnished.

## ARTICLE 12 UNCOVERING AND CORRECTION OF WORK

### § 12.1 UNCOVERING OF WORK

§ 12.1.1 If a portion of the Work is covered contrary to the Architect's request or to requirements specifically expressed in the Contract Documents, it must, if requested in writing by the Architect, be uncovered for the Architect's examination and be replaced at the Contractor's expense without change in the Contract Time.

§ 12.1.2 If a portion of the Work has been covered that the Architect has not specifically requested to examine prior to its being covered, the Architect may request to see such Work and it shall be uncovered by the Contractor. If such Work is in accordance with the Contract Documents, costs of uncovering and replacement shall, by appropriate Change Order, be at the Owner's expense. If such Work is not in accordance with the Contract Documents, such costs and the cost of correction shall be at the Contractor's expense unless the condition was caused by the Owner or a separate contractor in which event the Owner shall be responsible for payment of such costs.

### § 12.2 CORRECTION OF WORK

#### § 12.2.1 BEFORE OR AFTER SUBSTANTIAL COMPLETION

The Contractor shall promptly correct Work rejected by the Architect or failing to conform to the requirements of the Contract Documents, whether discovered before or after Substantial Completion and whether or not fabricated, installed or completed. Costs of correcting such rejected Work, including additional testing and inspections, the cost of

Init.

uncovering and replacement, and compensation for the Architect's services and expenses made necessary thereby, shall be at the Contractor's expense.

#### **§ 12.2.2 AFTER SUBSTANTIAL COMPLETION**

**§ 12.2.2.1** In addition to the Contractor's obligations under Section 3.5, if, within one year after the date of Substantial Completion of the Work or designated portion thereof or after the date for commencement of warranties established under Section 9.9.1, or by terms of an applicable special warranty required by the Contract Documents, any of the Work is found to be not in accordance with the requirements of the Contract Documents, the Contractor shall correct it promptly after receipt of written notice from the Owner to do so unless the Owner has previously given the Contractor a written acceptance of such condition. The Owner shall give such notice promptly after discovery of the condition. During the one-year period for correction of Work, if the Owner fails to notify the Contractor and give the Contractor an opportunity to make the correction, the Owner waives the rights to require correction by the Contractor and to make a claim for breach of warranty. If the Contractor fails to correct nonconforming Work within a reasonable time during that period after receipt of notice from the Owner or Architect, the Owner may correct it in accordance with Section 2.4.

**§ 12.2.2.2** The one-year period for correction of Work shall be extended with respect to portions of Work first performed after Substantial Completion by the period of time between Substantial Completion and the actual completion of that portion of the Work.

**§ 12.2.2.3** The one-year period for correction of Work shall not be extended by corrective Work performed by the Contractor pursuant to this Section 12.2.

**§ 12.2.3** The Contractor shall remove from the site portions of the Work that are not in accordance with the requirements of the Contract Documents and are neither corrected by the Contractor nor accepted by the Owner.

**§ 12.2.4** The Contractor shall bear the cost of correcting destroyed or damaged construction, whether completed or partially completed, of the Owner or separate contractors caused by the Contractor's correction or removal of Work that is not in accordance with the requirements of the Contract Documents.

**§ 12.2.5** Nothing contained in this Section 12.2 shall be construed to establish a period of limitation with respect to other obligations the Contractor has under the Contract Documents. Establishment of the one-year period for correction of Work as described in Section 12.2.2 relates only to the specific obligation of the Contractor to correct the Work, and has no relationship to the time within which the obligation to comply with the Contract Documents may be sought to be enforced, nor to the time within which proceedings may be commenced to establish the Contractor's liability with respect to the Contractor's obligations other than specifically to correct the Work.

#### **§ 12.3 ACCEPTANCE OF NONCONFORMING WORK**

If the Owner prefers to accept Work that is not in accordance with the requirements of the Contract Documents, the Owner may do so instead of requiring its removal and correction, in which case the Contract Sum will be reduced as appropriate and equitable. Such adjustment shall be effected whether or not final payment has been made.

### **ARTICLE 13 MISCELLANEOUS PROVISIONS**

#### **§ 13.1 GOVERNING LAW**

The rights and duties arising under this Agreement shall be governed by the laws of the State of Illinois. Venue for any action arising out or due to this Agreement shall be in Cook County, Illinois. The City shall not enter into binding arbitration to resolve any dispute under this Agreement. The City does not waive tort immunity by entering into this Agreement.

#### **§ 13.2 SUCCESSORS AND ASSIGNS**

**§ 13.2.1** The Owner and Contractor respectively bind themselves, their partners, successors, assigns and legal representatives to covenants, agreements and obligations contained in the Contract Documents. Except as provided in Section 13.2.2, neither party to the Contract shall assign the Contract as a whole without written consent of the other. If either party attempts to make such an assignment without such consent, that party shall nevertheless remain legally responsible for all obligations under the Contract.

§ 13.2.2 The Owner may, without consent of the Contractor, assign the Contract to a lender providing construction financing for the Project, if the lender assumes the Owner's rights and obligations under the Contract Documents. The Contractor shall execute all consents reasonably required to facilitate such assignment.

### § 13.3 WRITTEN NOTICE

Written notice shall be deemed to have been duly served if delivered in person to the individual, to a member of the firm or entity, or to an officer of the corporation for which it was intended; or if delivered at, or sent by registered or certified mail or by courier service providing proof of delivery to, the last business address known to the party giving notice.

### § 13.4 RIGHTS AND REMEDIES

§ 13.4.1 Duties and obligations imposed by the Contract Documents and rights and remedies available thereunder shall be in addition to and not a limitation of duties, obligations, rights and remedies otherwise imposed or available by law.

§ 13.4.2 No action or failure to act by the Owner, Architect or Contractor shall constitute a waiver of a right or duty afforded them under the Contract, nor shall such action or failure to act constitute approval of or acquiescence in a breach there under, except as may be specifically agreed in writing.

### § 13.5 TESTS AND INSPECTIONS

§ 13.5.1 Tests, inspections and approvals of portions of the Work shall be made as required by the Contract Documents and by applicable laws, statutes, ordinances, codes, rules and regulations or lawful orders of public authorities. Unless otherwise provided, the Contractor shall make arrangements for such tests, inspections and approvals with an independent testing laboratory or entity acceptable to the Owner, or with the appropriate public authority, and shall bear all related costs of tests, inspections and approvals. The Contractor shall give the Architect timely notice of when and where tests and inspections are to be made so that the Architect may be present for such procedures. The Owner shall bear costs of (1) tests, inspections or approvals that do not become requirements until after bids are received or negotiations concluded, and (2) tests, inspections or approvals where building codes or applicable laws or regulations prohibit the Owner from delegating their cost to the Contractor.

§ 13.5.2 If the Architect, Owner or public authorities having jurisdiction determine that portions of the Work require additional testing, inspection or approval not included under Section 13.5.1, the Architect will, upon written authorization from the Owner, instruct the Contractor to make arrangements for such additional testing, inspection or approval by an entity acceptable to the Owner, and the Contractor shall give timely notice to the Architect of when and where tests and inspections are to be made so that the Architect may be present for such procedures. Such costs, except as provided in Section 13.5.3, shall be at the Owner's expense.

§ 13.5.3 If such procedures for testing, inspection or approval under Sections 13.5.1 and 13.5.2 reveal failure of the portions of the Work to comply with requirements established by the Contract Documents, all costs made necessary by such failure including those of repeated procedures and compensation for the Architect's services and expenses shall be at the Contractor's expense.

§ 13.5.4 Required certificates of testing, inspection or approval shall, unless otherwise required by the Contract Documents, be secured by the Contractor and promptly delivered to the Architect.

§ 13.5.5 If the Architect is to observe tests, inspections or approvals required by the Contract Documents, the Architect will do so promptly and, where practicable, at the normal place of testing.

§ 13.5.6 Tests or inspections conducted pursuant to the Contract Documents shall be made promptly to avoid unreasonable delay in the Work.

### § 13.6 INTEREST

Invoices for payment will be paid in accordance with the Illinois Local Government Prompt Payment Act, 50 ILCS 505/et seq.

### § 13.7 TIME LIMITS ON CLAIMS

The Owner and Contractor shall commence all claims and causes of action, whether in contract, tort, breach of warranty or otherwise, against the other arising out of or related to the Contract in accordance with the requirements of

Init.

AIA Document A201™ – 2007. Copyright © 1911, 1915, 1918, 1925, 1937, 1951, 1958, 1961, 1963, 1966, 1970, 1976, 1987, 1997 and 2007 by The American Institute of Architects. All rights reserved. **WARNING: This AIA® Document is protected by U.S. Copyright Law and International Treaties. Unauthorized reproduction or distribution of this AIA® Document, or any portion of it, may result in severe civil and criminal penalties, and will be prosecuted to the maximum extent possible under the law.** This document was produced by AIA software at 10 01:17 on 02/26/2018 under Order No 2737583500 which expires on 10/24/2018 and is not for resale.

User Notes:

(1953391157)

the final dispute resolution method selected in the Agreement within the time period specified by applicable law, but in any case not more than 10 years after the date of Substantial Completion of the Work. The Owner and Contractor waive all claims and causes of action not commenced in accordance with this Section 13.7.

## ARTICLE 14 TERMINATION OR SUSPENSION OF THE CONTRACT

### § 14.1 TERMINATION BY THE CONTRACTOR

§ 14.1.1 The Contractor may terminate the Contract if the Work is stopped for a period of 30 consecutive days through no act or fault of the Contractor or a Subcontractor, Sub-subcontractor or their agents or employees or any other persons or entities performing portions of the Work under direct or indirect contract with the Contractor, for any of the following reasons:

- .1 Issuance of an order of a court or other public authority having jurisdiction that requires all Work to be stopped;
- .2 An act of government, such as a declaration of national emergency that requires all Work to be stopped;
- .3 Because the Architect has not issued a Certificate for Payment and has not notified the Contractor of the reason for withholding certification as provided in Section 9.4.1, or because the Owner has not made payment on a Certificate for Payment within the time stated in the Contract Documents; or
- .4 The Owner has failed to furnish to the Contractor promptly, upon the Contractor's request, reasonable evidence as required by Section 2.2.1.

§ 14.1.2 The Contractor may terminate the Contract if, through no act or fault of the Contractor or a Subcontractor, Sub-subcontractor or their agents or employees or any other persons or entities performing portions of the Work under direct or indirect contract with the Contractor, repeated suspensions, delays or interruptions of the entire Work by the Owner as described in Section 14.3 constitute in the aggregate more than 100 percent of the total number of days scheduled for completion, or 120 days in any 365-day period, whichever is less.

§ 14.1.3 If one of the reasons described in Section 14.1.1 or 14.1.2 exists, the Contractor may, upon seven days' written notice to the Owner and Architect, terminate the Contract and recover from the Owner payment for Work executed, including reasonable overhead and profit, costs incurred by reason of such termination, and damages.

§ 14.1.4 If the Work is stopped for a period of 60 consecutive days through no act or fault of the Contractor or a Subcontractor or their agents or employees or any other persons performing portions of the Work under contract with the Contractor because the Owner has repeatedly failed to fulfill the Owner's obligations under the Contract Documents with respect to matters important to the progress of the Work, the Contractor may, upon seven additional days' written notice to the Owner and the Architect, terminate the Contract and recover from the Owner as provided in Section 14.1.3.

### § 14.2 TERMINATION BY THE OWNER FOR CAUSE

§ 14.2.1 The Owner may terminate the Contract if the Contractor

- .1 repeatedly refuses or fails to supply enough properly skilled workers or proper materials;
- .2 fails to make payment to Subcontractors for materials or labor in accordance with the respective agreements between the Contractor and the Subcontractors;
- .3 repeatedly disregards applicable laws, statutes, ordinances, codes, rules and regulations, or lawful orders of a public authority; or
- .4 otherwise is guilty of substantial breach of a provision of the Contract Documents.

§ 14.2.2 When any of the above reasons exist, the Owner, may without prejudice to any other rights or remedies of the Owner and after giving the Contractor and the Contractor's surety, if any, seven days' written notice, terminate employment of the Contractor and may, subject to any prior rights of the surety:

- .1 Exclude the Contractor from the site and take possession of all materials, equipment, tools, and construction equipment and machinery thereon owned by the Contractor;
- .2 Accept assignment of subcontracts pursuant to Section 5.4; and
- .3 Finish the Work by whatever reasonable method the Owner may deem expedient. Upon written request of the Contractor, the Owner shall furnish to the Contractor a detailed accounting of the costs incurred by the Owner in finishing the Work.

§ 14.2.3 When the Owner terminates the Contract for one of the reasons stated in Section 14.2.1, the Contractor shall not be entitled to receive further payment until the Work is finished.

Init.

AIA Document A201™ – 2007. Copyright © 1911, 1915, 1918, 1925, 1937, 1951, 1958, 1961, 1963, 1966, 1970, 1976, 1987, 1997 and 2007 by The American Institute of Architects. All rights reserved. **WARNING: This AIA® Document is protected by U.S. Copyright Law and International Treaties. Unauthorized reproduction or distribution of this AIA® Document, or any portion of it, may result in severe civil and criminal penalties, and will be prosecuted to the maximum extent possible under the law.** This document was produced by AIA software at 10:01:17 on 02/26/2018 under Order No.2737583500 which expires on 10/24/2018, and is not for resale.

User Notes:

(1953391157)



§ 14.2.4 If the unpaid balance of the Contract Sum exceeds costs of finishing the Work, including compensation for the Architect's services and expenses made necessary thereby, and other damages incurred by the Owner and not expressly waived, such excess shall be paid to the Contractor. If such costs and damages exceed the unpaid balance, the Contractor shall pay the difference to the Owner. This obligation for payment shall survive termination of the Contract.

#### § 14.3 SUSPENSION BY THE OWNER FOR CONVENIENCE

§ 14.3.1 The Owner may, without cause, order the Contractor in writing to suspend, delay or interrupt the Work in whole or in part for such period of time as the Owner may determine.

§ 14.3.2 The Contract Sum and Contract Time shall be adjusted for increases in the cost and time caused by suspension, delay or interruption as described in Section 14.3.1. Adjustment of the Contract Sum shall include profit. No adjustment shall be made to the extent

- .1 that performance is, was or would have been so suspended, delayed or interrupted by another cause for which the Contractor is responsible; or
- .2 that an equitable adjustment is made or denied under another provision of the Contract.

#### § 14.4 TERMINATION BY THE OWNER FOR CONVENIENCE

§ 14.4.1 The Owner may, at any time, terminate the Contract for the Owner's convenience and without cause.

§ 14.4.2 Upon receipt of written notice from the Owner of such termination for the Owner's convenience, the Contractor shall

- .1 cease operations as directed by the Owner in the notice;
- .2 take actions necessary, or that the Owner may direct, for the protection and preservation of the Work; and
- .3 except for Work directed to be performed prior to the effective date of termination stated in the notice, terminate all existing subcontracts and purchase orders and enter into no further subcontracts and purchase orders.

§ 14.4.3 In case of such termination for the Owner's convenience, the Contractor shall be entitled to receive payment for Work executed, and costs incurred by reason of such termination, along with reasonable overhead and profit on the Work not executed.

### ARTICLE 15 CLAIMS AND DISPUTES

#### § 15.1 CLAIMS

##### § 15.1.1 DEFINITION

A Claim is a demand or assertion by one of the parties seeking, as a matter of right, payment of money, or other relief with respect to the terms of the Contract. The term "Claim" also includes other disputes and matters in question between the Owner and Contractor arising out of or relating to the Contract. The responsibility to substantiate Claims shall rest with the party making the Claim.

##### § 15.1.2 NOTICE OF CLAIMS

Claims by either the Owner or Contractor must be initiated by written notice to the other party. Claims by either party must be initiated within 21 days after occurrence of the event giving rise to such Claim or within 21 days after the claimant first recognizes the condition giving rise to the Claim, whichever is later.

##### § 15.1.3 CONTINUING CONTRACT PERFORMANCE

Pending final resolution of a Claim, except as otherwise agreed in writing or as provided in Section 9.7 and Article 14, the Contractor shall proceed diligently with performance of the Contract and the Owner shall continue to make payments in accordance with the Contract Documents.

##### § 15.1.4 CLAIMS FOR ADDITIONAL COST

If the Contractor wishes to make a Claim for an increase in the Contract Sum, written notice as provided herein shall be given before proceeding to execute the Work. Prior notice is not required for Claims relating to an emergency endangering life or property arising under Section 10.4.

### § 15.1.5 CLAIMS FOR ADDITIONAL TIME

§ 15.1.5.1 If the Contractor wishes to make a Claim for an increase in the Contract Time, written notice as provided herein shall be given. The Contractor's Claim shall include an estimate of cost and of probable effect of delay on progress of the Work. In the case of a continuing delay, only one Claim is necessary.

§ 15.1.5.2 If adverse weather conditions are the basis for a Claim for additional time, such Claim shall be documented by data substantiating that weather conditions were abnormal for the period of time, could not have been reasonably anticipated and had an adverse effect on the scheduled construction.

### § 15.1.6 CLAIMS FOR CONSEQUENTIAL DAMAGES

The Contractor and Owner waive Claims against each other for consequential damages arising out of or relating to this Contract. This mutual waiver includes

- .1 damages incurred by the Owner for rental expenses, for losses of use, income, profit, financing, business and reputation, and for loss of management or employee productivity or of the services of such persons; and
- .2 damages incurred by the Contractor for principal office expenses including the compensation of personnel stationed there, for losses of financing, business and reputation, and for loss of profit except anticipated profit arising directly from the Work.

This mutual waiver is applicable, without limitation, to all consequential damages due to either party's termination in accordance with Article 14. Nothing contained in this Section 15.1.6 shall be deemed to preclude an award of liquidated damages, when applicable, in accordance with the requirements of the Contract Documents.

*(Paragraphs deleted)*

§ 15.2.7 In the event of a Claim against the Contractor, the Owner may, but is not obligated to, notify the surety, if any, of the nature and amount of the Claim. If the Claim relates to a possibility of a Contractor's default, the Owner may, but is not obligated to, notify the surety and request the surety's assistance in resolving the controversy.

§ 15.2.8 If a Claim relates to or is the subject of a mechanic's lien, the party asserting such Claim may proceed in accordance with applicable law to comply with the lien notice or filing deadlines.

*(Paragraphs deleted)*

### § 15.4.4 CONSOLIDATION OR JOINDER

§ 15.4.4.1 Either party, at its sole discretion, may consolidate an arbitration conducted under this Agreement with any other arbitration to which it is a party provided that (1) the arbitration agreement governing the other arbitration permits consolidation, (2) the arbitrations to be consolidated substantially involve common questions of law or fact, and (3) the arbitrations employ materially similar procedural rules and methods for selecting arbitrator(s).

§ 15.4.4.2 Either party, at its sole discretion, may include by joinder persons or entities substantially involved in a common question of law or fact whose presence is required if complete relief is to be accorded in arbitration, provided that the party sought to be joined consents in writing to such joinder. Consent to arbitration involving an additional person or entity shall not constitute consent to arbitration of any claim, dispute or other matter in question not described in the written consent.

§ 15.4.4.3 The Owner and Contractor grant to any person or entity made a party to an arbitration conducted under this Section 15.4, whether by joinder or consolidation, the same rights of joinder and consolidation as the Owner and Contractor under this Agreement.

Init.

# Additions and Deletions Report for AIA® Document A201™ – 2007

This Additions and Deletions Report, as defined on page 1 of the associated document, reproduces below all text the author has added to the standard form AIA document in order to complete it, as well as any text the author may have added to or deleted from the original AIA text. Added text is shown underlined. Deleted text is indicated with a horizontal line through the original AIA text.

Note: This Additions and Deletions Report is provided for information purposes only and is not incorporated into or constitute any part of the associated AIA document. This Additions and Deletions Report and its associated document were generated simultaneously by AIA software at 10:01:17 on 02/26/2018.

## PAGE 1

Robert Crown Community Center, Ice Complex, and Library  
1801 Main Street Evanston, Illinois, 60202

...

City of Evanston  
2100 Ridge Avenue  
Evanston, Illinois 60201

...

Woodhouse Tinucci Architects  
230 W Superior Street 6FL  
Chicago, IL 60654  
PAGE 2

8.3.1, ~~11.3.10, 13.1, 15.3.2, 15.4, 13.1~~

...

2.4, 3.12.7, 4.1, 4.2, 5.2, 6.3, 7.1.2, 7.3.7, 7.4, 9.2, 9.3.1, 9.4, 9.5, 9.6.3, 9.8, 9.10.1, 9.10.3, 12.1, 12.2.1, 13.5.1, 13.5.2, 14.2.2, 14.2.4, 15.1.3, ~~15.2.1~~

...

3.7.4, 4.2.6, 4.2.7, 4.2.11, 4.2.12, 4.2.13, 4.2.14, 6.3, 7.3.7, 7.3.9, 8.1.3, 8.3.1, 9.2, 9.4.1, 9.5, 9.8.4, 9.9.1, 13.5.2, ~~15.2, 15.3, 15.2~~

...

1.1.2, 1.5, 3.1.3, 3.2.2, 3.2.3, 3.2.4, 3.3.1, 3.4.2, 3.5, 3.7.4, 3.7.5, 3.9.2, 3.9.3, 3.10, 3.11, 3.12, 3.16, 3.18, 4.1.2, 4.1.3, 4.2, 5.2, 6.2.2, 7, 8.3.1, 9.2, 9.3, 9.4, 9.5, 9.7, 9.8, 9.9, 10.2.6, 10.3, ~~11.3.7, 12, 13.4.2, 13.5, 15.2~~

...

1.1.2, 4.2.3, 4.2.4, 4.2.6, 9.6.3, 9.6.4, ~~11.3.7~~

...

9.7, ~~11.3.9, 11.3.10, 13.1, 15.2.5, 15.2.6.1, 15.3.1, 15.3.2, 15.4.1, 13.1, 15.2.1~~

...

7.3.7.4, 9.6.7, 9.10.3, ~~11.3.9~~, 11.4

**PAGE 3**

1.1.1, 2.4, 3.4.2, 3.7.4, 3.8.2.3, 3.11, 3.12.8, 4.2.8, 5.2.3, 7.1.2, 7.1.3, ~~7.2~~, 7.3.2, 7.3.6, 7.3.9, 7.3.10, 8.3.1, 9.3.1.1, 9.10.3, 10.3.2, 11.3.1.2, 11.3.4, ~~11.3.9~~, 12.1.2, 15.1.3

...

2.2.1, 3.11, 4.2.8, 7, 7.2.1, 7.3.1, 7.4, 8.3.1, 9.3.1.1, ~~11.3.9~~

...

3.2.4, 6.1.1, 6.3, 7.3.9, 9.3.3, 9.10.4, 10.3.3, ~~15, 15.4~~ 15

~~Claims and Timely Assertion of Claims~~

~~15.4.1~~

**Claims for Additional Cost**

...

3.2.4, 3.18, 6.1.1, 8.3.3, 9.5.1, 9.6.7, 10.3.3, 11.1.1, 11.3.5, ~~11.3.7~~, 14.1.3, 14.2.4, 15.1.6

~~Claims Subject to Arbitration~~

~~15.3.1, 15.4.1~~

...

1.6, 3.2.3, 3.6, 3.7, 3.12.10, 3.13, 4.1.1, 9.6.4, 10.2.2, 11.1, 11.3, 13.1, 13.4, 13.5.1, 13.5.2, 13.6, 14.1.1, 14.2.1.3, ~~15.2.8, 15.4.2, 15.4.3~~ 15.2.8

...

5.4.1.1, ~~11.3.9~~, 14

...

3.7.4, 3.8, 5.2.3, 7.2, 7.3, 7.4, ~~9.1~~, 9.4.2, 9.5.1.4, 9.6.7, 9.7, 10.3.2, 11.3.1, 14.2.4, 14.3.2, 15.1.4, ~~15.2.5~~

...

3.7.4, 3.7.5, 3.10.2, 5.2.3, 7.2.1.3, 7.3.1, 7.3.5, 7.4, 8.1.1, 8.2.1, 8.3.1, 9.5.1, 9.7, 10.3.2, 12.1.1, 14.3.2, 15.1.5.1, ~~15.2.5~~

**PAGE 4**

3.3.2, 3.4.3, 3.8.1, 3.9, 3.18.2, 4.2.3, 4.2.6, 10.2, 10.3, 11.1.1, ~~11.3.7~~,

14.1, 14.2.1.1

...

3.12.5, 3.14.2, 4.2.4, 6, ~~11.3.7~~,

12.1.2, 12.2.4

...

1.2.2, 3.3.2, 3.18.1, 3.18.2, 5, 9.6.2, 9.6.7, 9.10.2, 11.3.1.2, ~~11.3.7~~, ~~11.3.8~~

2

...

1.1.2, 1.5, 3.1.3, 3.2.2, 3.2.3, 3.2.4, 3.3.1, 3.4.2, 3.5, 3.7.4, 3.10, 3.11, 3.12, 3.16, 3.18, 4.1.3, 4.2, 5.2, 6.2.2, 7, 8.3.1, 9.2, 9.3, 9.4, 9.5, 9.7, 9.8, 9.9, 10.2.6, 10.3, ~~11.3.7,~~  
~~12, 13.5, 15.1.2, 15.2.1~~

...

~~11.1.1.8,~~ 11.1.1.2

...

3.2.4, 3.18, 6.1.1, 8.3.3, 9.5.1, 9.6.7, 10.3.3, 11.1.1, 11.3.5, ~~11.3.7,~~  
~~14.1.3, 14.2.4, 15.1.6~~

...

3.2, 3.7.4, 5.2.3, 7.2.1, 7.3.1, 7.4, 8.3, 9.5.1, 9.7, 10.3.2, 10.4, 14.3.2, 15.1.5, ~~15.2.5~~

...

3.3.2, 3.4.3, 3.8.1, 3.9, 3.18.2, 4.2.3, 4.2.6, 10.2, 10.3.3, 11.1.1, ~~11.3.7,~~  
~~14.1, 14.2.1.1~~

**PAGE 5**

3.2.4, 3.7.4, 5.2.3, 7.2.1, 7.3, 7.4, 9.5.1, 9.7, 10.3.2, 10.4, 14.3, 15.1.5, ~~15.2.5~~

...

3.17, 3.18, 9.10.2, 10.3.3, 10.3.5, 10.3.6, 11.3.1.2, ~~11.3.7~~

...

**Initial Decision Maker, Definition of**

~~1.1.8~~

**Initial Decision Maker, Decisions**

~~14.2.2, 14.2.4, 15.2.1, 15.2.2, 15.2.3, 15.2.4, 15.2.5~~

**Initial Decision Maker, Extent of Authority**

~~14.2.2, 14.2.4, 15.1.3, 15.2.1, 15.2.2, 15.2.3, 15.2.4, 15.2.5~~

**Judgment on Final Award**

~~15.4.2~~

...

1.5, 3.2.3, 3.6, 3.7, 3.12.10, 3.13, 4.1.1, 9.6.4, 9.9.1, 10.2.2, 11.1.1, 11.3, 13.1, 13.4, 13.5.1, 13.5.2, 13.6, 14, ~~15.2.8,~~  
~~15.4.1, 15.2.8~~

...

~~12.2.5, 13.7, 15.4.1.1~~ 13.7

...

2.3, 3.2.2, 3.5, 3.12.10, 3.17, 3.18.1, 4.2.6, 4.2.7, 4.2.12, 6.2.2, 9.4.2, 9.6.4, 9.6.7, 10.2.5, 10.3.3, 11.1.2, 11.2, ~~11.3.7,~~  
~~12.2.5, 13.4.2~~

...

2.1.2, 2.2, 2.4, 3.2.2, 3.10, 3.11, 3.12.5, 3.15.1, 4.2.7, 5.2, 5.3, 5.4.1, 6.2.4, 7.3, 7.4, 8.2, 9.2, 9.3.1, 9.3.3, 9.4.1, 9.5, 9.6, 9.7, 9.8, 9.9, 9.10, 11.1.3, 11.3.1.5, 11.3.6, ~~11.3.10, 12.2, 13.5, 13.7, 14, 15~~

PAGE 6

8.3.1, 10.3.5, 10.3.6, ~~15.2.1, 15.2.5, 15.2.6, 15.3, 15.4.1~~

...

2.2.1, 2.3, 2.4, 3.2.4, 3.3.1, 3.7.2, 3.12.9, 5.2.1, 9.7, 9.10, 10.2.2, 11.1.3, 12.2.2.1, 13.3, 13.5.1, 13.5.2, 14.1, 14.2, ~~15.2.8, 15.4.1~~ 15.2.8

...

2.3, 2.4, 3.3.1, 3.9.2, 3.12.9, 3.12.10, 5.2.1, 9.7, 9.10, 10.2.2, 10.3, 11.1.3, 11.3.6, 12.2.2.1, **13.3**, 14, 15.2.8, ~~15.4.1~~

...

3.7.4, 10.2.8, ~~15.1.2, 15.4~~ 15.1.2

...

1.1.1, 2.3, 3.9.2, 7, 8.2.2, ~~11.3.9, 12.1, 12.2.2.1, 13.5.2, 14.3.1~~

...

1.5, 2.1.1, 2.3, 2.4, 3.4.2, 3.8.1, 3.12.10, 3.14.2, 4.1.2, 4.1.3, 4.2.4, 4.2.9, 5.2.1, 5.2.4, 5.4.1, 6.1, 6.3, 7.2.1, 7.3.1, 8.2.2, 8.3.1, 9.3.1, 9.3.2, 9.5.1, 9.6.4, 9.9.1, 9.10.2, 10.3.2, 11.1.3, 11.3.3, ~~11.3.10, 12.2.2, 12.3, 13.2.2, 14.3, 14.4, 15.2.7~~  
PAGE 7

1.5, 3.2.3, 3.6, 3.7, 3.12.10, 3.13, 4.1.1, 9.6.4, 9.9.1, 10.2.2, 11.1, 11.4, 13.1, 13.4, 13.5.1, 13.5.2, 13.6, 14, ~~15.2.8, 15.4~~ 15.2.8

...

1.1.2, 2.3, 2.4, 3.5, 3.7.4, 3.15.2, 4.2.6, 5.3, 5.4, 6.1, 6.3, 7.3.1, 8.3, 9.5.1, 9.7, 10.2.5, 10.3, 12.2.2, 12.2.4, **13.4**, ~~14, 15.4~~ 14

...

**3.17**  
**Rules and Notices for Arbitration**  
**15.4.1**

...

~~13.7, 15.4.1~~ 13.7

...

6.1.1, ~~11.3.7~~  
PAGE 8

3.2.4, 3.7.4, 5.2.3, 7.2.1, 7.3.1, 7.4, **8.3**, 9.5.1, 9.7, 10.3.2, 10.4, 14.3.2, 15.1.5, ~~15.2.5~~

...

2.1.2, 2.2, 2.4, 3.2.2, 3.10, 3.11, 3.12.5, 3.15.1, 4.2, 5.2, 5.3, 5.4, 6.2.4, 7.3, 7.4, 8.2, 9.2, 9.3.1, 9.3.3, 9.4.1, 9.5, 9.6, 9.7, 9.8, 9.9, 9.10, 11.1.3, 12.2, 13.5, 13.7, 14, ~~15.1.2, 15.4~~15.1.2

...

6.1.1, ~~11.3.7~~

...

2.3, 2.4, 3.3.1, 3.9, 3.12.9, 3.12.10, 5.2.1, 8.2.2, 9.7, 9.10, 10.2.2, 10.3, 11.1.3, 12.2.2, 12.2.4, 13.3, ~~14, 15.4~~14  
**PAGE 9**

The Contract Documents are enumerated in the Agreement between the Owner and Contractor (hereinafter the Agreement) and consist of the Agreement, Conditions of the Contract (General, Supplementary and other Conditions), Drawings, Specifications, Addenda issued prior to execution of the Contract, other documents listed in the Agreement and Modifications issued after execution of the Contract. A Modification is (1) a written amendment to the Contract signed by both parties, (2) a Change Order, ~~(3) a Construction Change Directive or (4) a written order for a minor change in the Work issued by the Architect or (3) a Construction Change Directive.~~ Unless specifically enumerated in the Agreement, the Contract Documents do not include the advertisement or invitation to bid, Instructions to Bidders, sample forms, other information furnished by the Owner in anticipation of receiving bids or proposals, the Contractor's bid or proposal, or portions of Addenda relating to bidding requirements.

...

**~~§ 1.1.8 INITIAL DECISION MAKER~~**

~~The Initial Decision Maker is the person identified in the Agreement to render initial decisions on Claims in accordance with Section 15.2 and certify termination of the Agreement under Section 14.2.2.~~

**PAGE 10**

~~§ 1.5.1 The Architect and the Architect's consultants~~City of Evanston shall be deemed the authors and owners of their respective the Instruments of Service, including the Drawings and Specifications, and will retain all common law, statutory and other reserved rights, including copyrights. The Contractor, Subcontractors, Sub-subcontractors, and material or equipment suppliers shall not own or claim a copyright in the Instruments of Service. Submittal or distribution to meet official regulatory requirements or for other purposes in connection with this Project is not to be construed as publication in derogation of the ~~Architect's or Architect's consultants'~~City of Evanston's reserved rights.

**PAGE 12**

**§ 3.4.3** The Contractor shall enforce strict discipline and good order among the Contractor's employees and other persons carrying out the Work. The Contractor shall not permit employment of unfit persons or persons not properly skilled in tasks assigned to them. Vendor warrants that all services will be performed to meet the requirements of the Agreement in an efficient and effective manner by trained and competent personnel.

**PAGE 13**

The Contractor warrants to the Owner and Architect that materials and equipment furnished under the Contract ~~will be of good quality and new unless the Contract Documents require or permit otherwise. The Contractor further warrants that the Work will conform to the requirements of the Contract Documents and will be free from defects, except for those inherent in the quality of the Work the Contract Documents require or permit.~~ will: (a) conform to the standards, specifications, drawings, samples or descriptions furnished by the City or by the Architect and agreed to by the City, including but not limited to all specifications attached as exhibits hereto; (b) be merchantable, of good quality and free from defects for a period of twelve months or longer, if so specified in writing, and fit and sufficient for the intended use; (c) comply with all federal, state and City laws, regulations and ordinances pertaining to delivery of supplies; (d) be of good title and free and clear of all liens and encumbrances; . Work, materials, or equipment not conforming to

these requirements may be considered defective. The Contractor's warranty excludes remedy for damage or defect caused by abuse, alterations to the Work not executed by the Contractor, improper or insufficient maintenance, improper operation, or normal wear and tear and normal usage. If required by the Architect, the Contractor shall furnish satisfactory evidence as to the kind and quality of materials and equipment. Vendor agrees to reimburse the City for any losses, costs, damages or expenses, including without limitations, reasonable attorney's fees and expenses, arising from failure of the supplies to meet such warranties. To the extent that these terms conflict with the Supplemental Contract Provisions ¶13; A201-2007 will be the binding provisions on the issue of warranty.

Vendor shall insure that all manufacturers' warranties are transferred to the City and shall provide a copy of the warranty. These warranties shall be in addition to all other warranties, express, implied or statutory, and shall survive the City's payment, acceptance, inspection or failure to inspect the supplies.

...

The Contractor shall pay sales, consumer, use and similar taxes for the Work provided by the Contractor that are legally enacted when bids are received or negotiations concluded, whether or not yet effective or merely scheduled to go into effect. The City of Evanston is tax exempt and construction manager will submit sales tax exemption information prior to purchases to prevent sales tax from being assessed in the subject transaction.

...

§ 3.7.1 Unless otherwise provided in the Contract Documents, the Contractor shall secure and pay for (except for City of Evanston fees, as detailed below) the building permit as well as for other permits, fees, licenses, and inspections by government agencies necessary for proper execution and completion of the Work that are customarily secured after execution of the Contract and legally required at the time bids are received or negotiations concluded. All fees typically assessed by the City of Evanston for the construction of this project will be waived. This waiver does not apply to other government agencies.

PAGE 31

~~§ 11.3.5 If during the Project construction period the Owner insures properties, real or personal or both, at or adjacent to the site by property insurance under policies separate from those insuring the Project, or if after final payment property insurance is to be provided on the completed Project through a policy or policies other than those insuring the Project during the construction period, the Owner shall waive all rights in accordance with the terms of Section 11.3.7 for damages caused by fire or other causes of loss covered by this separate property insurance. All separate policies shall provide this waiver of subrogation by endorsement or otherwise.~~

#### § 11.3.7 WAIVERS OF SUBROGATION

~~The Owner and Contractor waive all rights against (1) each other and any of their subcontractors, sub-subcontractors, agents and employees, each of the other, and (2) the Architect, Architect's consultants, separate contractors described in Article 6, if any, and any of their subcontractors, sub-subcontractors, agents and employees, for damages caused by fire or other causes of loss to the extent covered by property insurance obtained pursuant to this Section 11.3 or other property insurance applicable to the Work, except such rights as they have to proceeds of such insurance held by the Owner as fiduciary. The Owner or Contractor, as appropriate, shall require of the Architect, Architect's consultants, separate contractors described in Article 6, if any, and the subcontractors, sub-subcontractors, agents and employees of any of them, by appropriate agreements, written where legally required for validity, similar waivers each in favor of other parties enumerated herein. The policies shall provide such waivers of subrogation by endorsement or otherwise. A waiver of subrogation shall be effective as to a person or entity even though that person or entity would otherwise have a duty of indemnification, contractual or otherwise, did not pay the insurance premium directly or indirectly, and whether or not the person or entity had an insurable interest in the property damaged.~~

~~§ 11.3.8 A loss insured under the Owner's property insurance shall be adjusted by the Owner as fiduciary and made payable to the Owner as fiduciary for the insureds, as their interests may appear, subject to requirements of any applicable mortgagee clause and of Section 11.3.10. The Contractor shall pay Subcontractors their just shares of insurance proceeds received by the Contractor, and by appropriate agreements, written where legally required for validity, shall require Subcontractors to make payments to their Sub-subcontractors in similar manner.~~



~~§ 11.3.9 If required in writing by a party in interest, the Owner as fiduciary shall, upon occurrence of an insured loss, give bond for proper performance of the Owner's duties. The cost of required bonds shall be charged against proceeds received as fiduciary. The Owner shall deposit in a separate account proceeds so received, which the Owner shall distribute in accordance with such agreement as the parties in interest may reach, or as determined in accordance with the method of binding dispute resolution selected in the Agreement between the Owner and Contractor. If after such loss no other special agreement is made and unless the Owner terminates the Contract for convenience, replacement of damaged property shall be performed by the Contractor after notification of a Change in the Work in accordance with Article 7.~~

~~§ 11.3.10 The Owner as fiduciary shall have power to adjust and settle a loss with insurers unless one of the parties in interest shall object in writing within five days after occurrence of loss to the Owner's exercise of this power; if such objection is made, the dispute shall be resolved in the manner selected by the Owner and Contractor as the method of binding dispute resolution in the Agreement. If the Owner and Contractor have selected arbitration as the method of binding dispute resolution, the Owner as fiduciary shall make settlement with insurers or, in the case of a dispute over distribution of insurance proceeds, in accordance with the directions of the arbitrators.~~

A. § 11.4.1 The Owner shall have the right to require the Contractor to furnish bonds covering faithful performance of the Contract and payment of obligations arising thereunder as stipulated in bidding requirements or specifically required in the Contract Documents on the date of execution of the Contract. The Construction Manager shall, within ten (10) calendar days after acceptance of the bid by the City, furnish a performance bond for 110% of the full amount of the contract from insurance companies having not less than A Policyholders Rating from the most recent Alfred M. Best and Co., Inc. listing available. Certification of the insurance company's rating shall be provided prior to contract implementation and quarterly thereafter until contract completion. Should such rating fall below the required A+ level during performance of the contract, it will be the contractor's responsibility to notify the City and provide a new bond from an insurance company whose rating meets the City's requirements.

PAGE 32

~~The Contract shall be governed by the law of the place where the Project is located except that, if the parties have selected arbitration as the method of binding dispute resolution, the Federal Arbitration Act shall govern Section 15.4.~~ rights and duties arising under this Agreement shall be governed by the laws of the State of Illinois. Venue for any action arising out or due to this Agreement shall be in Cook County, Illinois. The City shall not enter into binding arbitration to resolve any dispute under this Agreement. The City does not waive tort immunity by entering into this Agreement.

PAGE 33

~~Payments due and unpaid under the Contract Documents shall bear interest from the date payment is due at such rate as the parties may agree upon in writing or, in the absence thereof, at the legal rate prevailing from time to time at the place where the Project is located. Invoices for payment will be paid in accordance with the Illinois Local Government Prompt Payment Act, 50 ILCS 505/et seq.~~

PAGE 34

~~§ 14.2.2 When any of the above reasons exist, the Owner, upon certification by the Initial Decision Maker that sufficient cause exists to justify such action, may without prejudice to any other rights or remedies of the Owner and after giving the Contractor and the Contractor's surety, if any, seven days' written notice, terminate employment of the Contractor and may, subject to any prior rights of the surety:~~

PAGE 35

~~§ 14.2.4 If the unpaid balance of the Contract Sum exceeds costs of finishing the Work, including compensation for the Architect's services and expenses made necessary thereby, and other damages incurred by the Owner and not expressly waived, such excess shall be paid to the Contractor. If such costs and damages exceed the unpaid balance, the Contractor shall pay the difference to the Owner. The amount to be paid to the Contractor or Owner, as the case may be, shall be certified by the Initial Decision Maker, upon application, and this obligation for payment shall survive termination of the Contract.~~

...

Claims by either the Owner or Contractor must be initiated by written notice to the other party and to the Initial Decision Maker with a copy sent to the Architect, if the Architect is not serving as the Initial Decision Maker. Claims by either party must be initiated within 21 days after occurrence of the event giving rise to such Claim or within 21 days after the claimant first recognizes the condition giving rise to the Claim, whichever is later.

...

Pending final resolution of a Claim, except as otherwise agreed in writing or as provided in Section 9.7 and Article 14, the Contractor shall proceed diligently with performance of the Contract and the Owner shall continue to make payments in accordance with the Contract Documents. The Architect will prepare Change Orders and issue Certificates for Payment in accordance with the decisions of the Initial Decision Maker.

PAGE 36

#### **§ 15.2 INITIAL DECISION**

**§ 15.2.1** Claims, excluding those arising under Sections 10.3, 10.4, 11.3.9, and 11.3.10, shall be referred to the Initial Decision Maker for initial decision. The Architect will serve as the Initial Decision Maker, unless otherwise indicated in the Agreement. Except for those Claims excluded by this Section 15.2.1, an initial decision shall be required as a condition precedent to mediation of any Claim arising prior to the date final payment is due, unless 30 days have passed after the Claim has been referred to the Initial Decision Maker with no decision having been rendered. Unless the Initial Decision Maker and all affected parties agree, the Initial Decision Maker will not decide disputes between the Contractor and persons or entities other than the Owner.

**§ 15.2.2** The Initial Decision Maker will review Claims and within ten days of the receipt of a Claim take one or more of the following actions: (1) request additional supporting data from the claimant or a response with supporting data from the other party, (2) reject the Claim in whole or in part, (3) approve the Claim, (4) suggest a compromise, or (5) advise the parties that the Initial Decision Maker is unable to resolve the Claim if the Initial Decision Maker lacks sufficient information to evaluate the merits of the Claim or if the Initial Decision Maker concludes that, in the Initial Decision Maker's sole discretion, it would be inappropriate for the Initial Decision Maker to resolve the Claim.

**§ 15.2.3** In evaluating Claims, the Initial Decision Maker may, but shall not be obligated to, consult with or seek information from either party or from persons with special knowledge or expertise who may assist the Initial Decision Maker in rendering a decision. The Initial Decision Maker may request the Owner to authorize retention of such persons at the Owner's expense.

**§ 15.2.4** If the Initial Decision Maker requests a party to provide a response to a Claim or to furnish additional supporting data, such party shall respond, within ten days after receipt of such request, and shall either (1) provide a response on the requested supporting data, (2) advise the Initial Decision Maker when the response or supporting data will be furnished or (3) advise the Initial Decision Maker that no supporting data will be furnished. Upon receipt of the response or supporting data, if any, the Initial Decision Maker will either reject or approve the Claim in whole or in part.

**§ 15.2.5** The Initial Decision Maker will render an initial decision approving or rejecting the Claim, or indicating that the Initial Decision Maker is unable to resolve the Claim. This initial decision shall (1) be in writing; (2) state the reasons therefor; and (3) notify the parties and the Architect, if the Architect is not serving as the Initial Decision Maker, of any change in the Contract Sum or Contract Time or both. The initial decision shall be final and binding on the parties but subject to mediation and, if the parties fail to resolve their dispute through mediation, to binding dispute resolution.

**§ 15.2.6** Either party may file for mediation of an initial decision at any time, subject to the terms of Section 15.2.6.1.

**§ 15.2.6.1** Either party may, within 30 days from the date of an initial decision, demand in writing that the other party file for mediation within 60 days of the initial decision. If such a demand is made and the party receiving the demand fails to file for mediation within the time required, then both parties waive their rights to mediate or pursue binding dispute resolution proceedings with respect to the initial decision.

...

### **§ 15.3 MEDIATION**

**§ 15.3.1** Claims, disputes, or other matters in controversy arising out of or related to the Contract except those waived as provided for in Sections 9.10.4, 9.10.5, and 15.1.6 shall be subject to mediation as a condition precedent to binding dispute resolution.

**§ 15.3.2** The parties shall endeavor to resolve their Claims by mediation which, unless the parties mutually agree otherwise, shall be administered by the American Arbitration Association in accordance with its Construction Industry Mediation Procedures in effect on the date of the Agreement. A request for mediation shall be made in writing, delivered to the other party to the Contract, and filed with the person or entity administering the mediation. The request may be made concurrently with the filing of binding dispute resolution proceedings but, in such event, mediation shall proceed in advance of binding dispute resolution proceedings, which shall be stayed pending mediation for a period of 60 days from the date of filing, unless stayed for a longer period by agreement of the parties or court order. If an arbitration is stayed pursuant to this Section 15.3.2, the parties may nonetheless proceed to the selection of the arbitrator(s) and agree upon a schedule for later proceedings.

**§ 15.3.3** The parties shall share the mediator's fee and any filing fees equally. The mediation shall be held in the place where the Project is located, unless another location is mutually agreed upon. Agreements reached in mediation shall be enforceable as settlement agreements in any court having jurisdiction thereof.

### **§ 15.4 ARBITRATION**

**§ 15.4.1** If the parties have selected arbitration as the method for binding dispute resolution in the Agreement, any Claim subject to, but not resolved by, mediation shall be subject to arbitration which, unless the parties mutually agree otherwise, shall be administered by the American Arbitration Association in accordance with its Construction Industry Arbitration Rules in effect on the date of the Agreement. A demand for arbitration shall be made in writing, delivered to the other party to the Contract, and filed with the person or entity administering the arbitration. The party filing a notice of demand for arbitration must assert in the demand all Claims then known to that party on which arbitration is permitted to be demanded.

**§ 15.4.1.1** A demand for arbitration shall be made no earlier than concurrently with the filing of a request for mediation, but in no event shall it be made after the date when the institution of legal or equitable proceedings based on the Claim would be barred by the applicable statute of limitations. For statute of limitations purposes, receipt of a written demand for arbitration by the person or entity administering the arbitration shall constitute the institution of legal or equitable proceedings based on the Claim.

**§ 15.4.2** The award rendered by the arbitrator or arbitrators shall be final, and judgment may be entered upon it in accordance with applicable law in any court having jurisdiction thereof.

**§ 15.4.3** The foregoing agreement to arbitrate and other agreements to arbitrate with an additional person or entity duly consented to by parties to the Agreement shall be specifically enforceable under applicable law in any court having jurisdiction thereof.

## **Certification of Document's Authenticity**

**AIA® Document D401™ – 2003**

I, \_\_\_\_\_, hereby certify, to the best of my knowledge, information and belief, that I created the attached final document simultaneously with its associated Additions and Deletions Report and this certification at 10:01:17 on 02/26/2018 under Order No. 2737583500 from AIA Contract Documents software and that in preparing the attached final document I made no changes to the original text of AIA® Document A201™ – 2007, General Conditions of the Contract for Construction, as published by the AIA in its software, other than those additions and deletions shown in the associated Additions and Deletions Report.

\_\_\_\_\_  
*(Signed)*

\_\_\_\_\_  
*(Title)*

\_\_\_\_\_  
*(Dated)*

**CITY OF EVANSTON**  
**REQUEST FOR PROPOSAL**

**NUMBER: 17-57**

**for**

**Robert Crown Community Center and Ice Complex  
Construction Management Services**

**October 5, 2017**

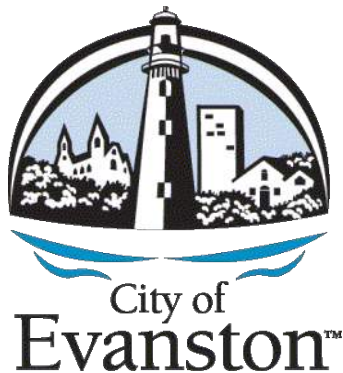

**PROPOSAL DEADLINE:** **2:00 P.M., November 7, 2017,**  
**Room 4200,**  
**Lorraine H. Morton Civic Center,**  
**2100 Ridge Avenue,**  
**Evanston, Illinois 60201**

**PRE-PROPOSAL MEETING:** **Non-mandatory**  
**1:00 P.M., October 12, 2017,**  
**Room 2404,**  
**Lorraine H. Morton Civic Center,**  
**2100 Ridge Avenue,**  
**Evanston, Illinois 60201**

**SEALED RESPONSES TO BE RETURNED TO:**

**CITY OF EVANSTON**  
**PURCHASING DIVISION, ROOM 4200**  
**LORRAINE H. MORTON CIVIC CENTER**  
**2100 RIDGE AVENUE**  
**EVANSTON, ILLINOIS 60201**  
**PHONE (847)866-2935 \* FAX (847)448-8128**

## TABLE OF CONTENTS

Notice to Proposers.....	3
1.0 Introduction.....	4
2.0 Scope of Services .....	10
3.0 Insurance.....	13
4.0 Submittal Requirements .....	14
5.0 Additional Submittal Requirements .....	16
<b>6.0 M/W/EBE Goals.....</b>	<b>16</b>
7.0 Local Employment Program Requirements .....	16
8.0 Evaluation Criteria .....	17
9.0 Selection Process.....	17
10.0 Proposed Schedule .....	18
11.0 Questions Regarding RFP.....	18
12.0 General Terms and Conditions.....	18
Exhibit A – Disclosure of Ownership Interests.....	24
Exhibit B – Additional Information Sheet .....	27
Exhibit C – Conflict of Interest Form.....	28
Exhibit D – Acknowledgement of Understanding.....	29
Exhibit E – Anti-Collusion Affidavit and Proposer’s Certification .....	30
<b>Exhibit F – City of Evanston M/W/EBE Policy.....</b>	<b>31</b>
<b>Exhibit G – M/W/EBE Participation Compliance Form .....</b>	<b>32</b>
<b>Exhibit H – M/W/EBE Participation Waiver Request.....</b>	<b>33</b>
Exhibit I – Construction Contractors Assistance Organizations.....	34
Exhibit J – Local Employment Program Compliance.....	35
Exhibit K – Certification of Compliance with Prevailing Wage Act.....	37
Exhibit L – Firm Experience Table.....	38
Exhibit M – Project Team Experience Table .....	39
Exhibit N – Reference Project Information Form .....	40
Exhibit O – Proposal Cost Table .....	41
Exhibit P – AIA Agreement Acknowledgement.....	42
Exhibit P – City of Evanston Modifications to AIA Contract A133-2009.....	43
<b>Exhibit Q – BID/Proposal Submittal Label.....</b>	<b>51</b>
Exhibit R – Schematic Design Documents .....	52
Exhibit S – Phase 1 Environmental Site Assessment.....	204
Exhibit T – Preliminary Geotechnical Subsurface Investigation Reports.....	426

## CITY OF EVANSTON

### NOTICE TO PROPOSERS

Sealed proposals will be received by the Purchasing Office in Room 4200, Lorraine H. Morton Civic Center, 2100 Ridge Avenue, Evanston, Illinois 60201, until 2:00 P.M. local time on November 7, 2017. Proposals shall cover the following:

**Robert Crown Community Center and Ice Complex**  
**Construction Management Services**  
**RFP Number: 17-57**

The City of Evanston's Public Works Agency is requesting proposals for construction management at-risk services for the construction of a new community center, library and ice complex in Evanston, Illinois.

There will be a non-mandatory pre-proposal meeting October 12, 2017 at 1:00 p.m. in Room 2404 of the Lorraine H. Morton Civic Center, 2100 Ridge Avenue, Evanston, IL 60201. All firms intending to submit a proposal for this project are encouraged to attend to discuss the proposed work and receive answers to questions related to the project.

The above item shall conform to the RFP on file in the Purchasing Office. The document, including all necessary plans and specifications, will be available in the Purchasing Office on October 5, 2017. Parties interested in submitting a response should contact the Purchasing Office to receive a copy of the RFP or see the City's website at: [www.cityofevanston.org/business/bids-proposals/](http://www.cityofevanston.org/business/bids-proposals/) or Demandstar at: [www.demandstar.com](http://www.demandstar.com).

The City (the City of Evanston) in accordance with the laws of the State of Illinois, hereby notifies all firms that it will affirmatively ensure that the contract(s) entered into pursuant to this notice will be awarded to the successful firm without discrimination on the grounds of race, color, religion, sex, age, sexual orientation marital status, disability, familial status or national origin. The State of Illinois requires under Public Works contracts that the general rate of wages in this locality be paid for each craft or type of worker hereunder. This requirement is in accordance with The Prevailing Wage Act (820 ILCS 130) as amended. The City of Evanston reserves the right to reject any or all submittals or to accept the submittal(s) deemed most advantageous to the City.

The Evanston City Council also reserves the right to award the contract to an Evanston firm if that firm's proposal is within 5% of the low bid.

Each Proposer shall be required to submit with his/her proposal a Disclosure of Ownership Interest Statement Form in accordance with Section 1-18-1 *et seq.* of the City Code. Failure to submit such information may result in the disqualification of such proposal.

Jillian Ostman  
Purchasing Specialist

**CITY OF EVANSTON**  
**Request for Proposals**

**1.0 INTRODUCTION**

1.1 Background Information

The City of Evanston is a general purpose municipal government located in Cook County, Illinois. It is a home rule unit, as defined in the 1970 Illinois Constitution, and operates under the Council/Manager form of government to provide for the health, safety and welfare of Evanston residents. A mayor, elected city-wide, and nine alderman elected by Ward, comprise the City Council. There are ten operating departments that provide a full array of services. The City has approximately 74,000 residents and a land area that covers 7.3 square miles.

The southern boundary of the City of Evanston borders the City of Chicago and is twelve miles north of downtown Chicago. The City is home to Northwestern University and Garrett Theological Seminary. In addition, the City is the home of two major teaching hospitals, Presence Saint Francis Hospital and North Shore University Health System Evanston Hospital, many corporations, service institutions, large national retailers and small entrepreneurial businesses.

The City currently owns and operates the Robert Crown Ice Rink and Community Center (Crown Center) located at 1701 Main Street. Constructed in 1975, the Crown Center was designed by the Evanston-based architectural firm of O'Donnell Wicklund Pigozzi Architects (now Cannon Design) with Weisinger-Holland Ltd. Structural engineers; Klaucens & Associates, mechanical-plumbing-electrical engineers; and Charles R. Beltz & Company, ice skating rink and equipment consultants.

The facility is a 61,000 square foot, one-story, masonry building. As one of the major recreational facilities in the community the Crown Center contains one large ice skating arena with seating for approximately 1,100 spectators, a small studio-practice rink, one basketball-sized gymnasium, a nursery-child care room, and a variety of other program/multi-purpose rooms. In addition, the Crown Center contains an assortment of support spaces including locker rooms, restrooms, a refreshment-food stand, reception area, skate rental, registration, ticket sales/program operations counter, storage rooms, offices, and equipment rooms.

After extensive building analysis, public discussion and program review over the past ten years, it has been determined that the Crown Center should be replaced with a new and larger facility, better designed to meet current community needs. Working with the architectural firms of Woodhouse Tinucci Architects (located in Chicago, Illinois) and MacLennan Jaunkalns Miller Architects (located in Toronto, Ontario), a schematic design for the new facility and park site was developed during the spring and summer of 2017. As design work moves into more detailed development, the City is now seeking the services of a construction management firm to assist with constructability review, cost estimating, and construction of the new facility and site. Upon successful completion of preconstruction



services, it is anticipated that the construction manager will ultimately assume the duties of a general contractor to construct the project.

## 1.2 Anticipated Program

The selected Construction Manager (CM) shall provide a wide array of professional and construction services directly to the City for this project. In general, work shall include constructability review, cost estimating, and construction services. All work shall be in compliance with current code requirements. The selected construction manager shall prepare all documents in the formats required by the City and shall adhere to all City deadlines so as not to impact the project schedule. The following building and site program elements are anticipated but are subject to further discussion and adjustment based on work performed during Task 1 below including examination of phased project implementation. Additional detail regarding the program and schematic design are provided as an attachment to this document. Both the attachment and the list of items below are goals for the project and the CM shall be tasked in evaluating these goals within the overall budget set by the City and Library:

### 1. Site Layout

- a. The new facility shall be situated in Crown Park just northeast of the intersection of Dodge Avenue and Main Street and the existing Robert Crown Center shall be demolished. This location will provide the new facility with more prominence as well as allow for continued operation of the existing Crown Center during the construction process.
- b. The new surface parking lot shall be situated directly east of the new facility along the southern edge of the park.
- c. The new exterior athletic fields shall be situated on the eastern half of Crown Park.

### 2. Ice Rinks (two rinks shall be constructed)

- a. Sheet one shall be NHL regulation size (85' x 200') with seating for approximately 1050 spectators.
- b. Sheet two shall be NHL regulation size (85' x 200') with seating for approximately 170 spectators.
- c. The ice rinks shall be served by 10 locker rooms (5 for each rink). Locker rooms shall be equipped with lockers, changing areas, benches, showers and toilet facilities. Two of the locker rooms shall be designed as "premium" spaces and include additional attached storage areas.
- d. Each ice sheet shall include a separate room for use by referees/judges.
- e. Each ice sheet shall include electronic scoreboards at each end of each rink.
- f. Each ice sheet shall be provided with technologically advanced A/V equipment capable of providing high quality sound, recording, televising and lighting for a wide variety of user needs.
- g. Each ice sheet shall include ample storage for materials and athletic equipment.
- h. Each ice sheet shall be served by a centralized refrigeration system and ice resurfacing equipment.
- i. Each ice sheet shall include an integrated storage system for public skate storage.

### 3. Gymnasium

- a. One large open gymnasium space shall be constructed. The gymnasium shall be large enough to accommodate two full court basketball games and shall be designed for a wide range of sports activities including basketball, volleyball, indoor soccer, batting practice and gymnastics.
- b. The gymnasium shall include retractable seating for 300 spectators.
- c. The gymnasium shall include operable dividers or netting capable of segregating the area into smaller spaces.
- d. The gymnasium shall be provided with technologically advanced A/V equipment capable of providing high quality sound, recording, televising and lighting for a wide variety of user needs.
- e. The gymnasium shall include a total of two locker rooms equipped with lockers, changing areas, benches, showers and toilet facilities.
- f. The gymnasium shall include a minimum of two electronic scoreboards.
- g. The gymnasium shall include ample storage areas for materials and athletic equipment.
- h. The gymnasium furnishings, equipment and flooring system shall be capable of supporting multiple sports activities minimally including basketball, volleyball, indoor soccer and gymnastics.

### 4. Community Branch Library

- a. A 6000 square foot branch library shall be constructed.
- b. The library shall include multipurpose and study rooms with electrical and USB outlets as well as integrated Wi-Fi. Multipurpose rooms shall include projectors and screens and soundproofing to isolate the library from any noise created by programs within multipurpose rooms.
- c. The library shall include storage carts for laptops and tables/chairs to allow for pop-up computer classes and programs and flexible computer use by patrons throughout the space.
- d. The library shall include a joint Circulation and Reference public service desk with good visual control of the entire public space.
- e. The library shall include embedded library material vending machine and HOLDS pickup lockers in a common interior wall, publicly accessible when the Crown Center is open and the Library is closed.
- f. The library shall include higher shelving around the perimeter and lower shelving throughout to provide for books, materials and magazines.
- g. The library shall include flexible floor space for creative hands-on programming for all ages.
- h. The library shall include an outdoor reading garden (not included in square footage described above) which is accessible through the library.
- i. The library shall include flat screen monitors and display surfaces to assist in marketing.
- j. The library shall include key card access to staff areas and surveillance cameras for security control.
- k. The library shall include public restroom access in the community center facilities and adjacent to the Library.
- l. The library shall include an exterior drive up book drop for visitors to drop off library materials.
- m. The library shall include self-check machines to assist with efficient check-out of materials.

- n. The library shall include a staff workroom and restroom.
  - o. The library shall include storage for books and materials.
  - p. The library shall include book drop “room”. The book drop will be publicly accessible when the Crown Center is open and the Library is closed.
  - q. The library shall include access to electrical power and Wi-Fi throughout the library.
5. Running Track
- a. A four lane running track will be provided.
  - b. The track shall be 200 meters in length.
  - c. The track shall be furnished with an appropriate shock absorbing athletic flooring system.
6. Fitness/Dance Room
- a. A fitness and dance room shall be constructed which is large enough to accommodate 15 to 20 people at a time.
  - b. This room shall be furnished with a wood flooring system and shall include mirrors and ballet barres.
  - c. Furnishings within the fitness facility shall be determined during the design development task.
7. Lobby
- a. The lobby shall be bright, inviting, modern, centralized and easily navigable.
  - b. The lobby shall contain ample natural light and include a mixture of fixed and flexible seating.
  - c. The lobby shall include adequate area for “pop-up” activities and events including space for traveling exhibits.
  - d. The lobby shall be large enough to handle a variety of vendor setups as well as overflow from events.
8. Multipurpose Rooms (four rooms shall be constructed)
- a. Two multipurpose rooms shall be constructed to accommodate a variety of community programming activities.
  - b. One multipurpose room shall be constructed to accommodate art classes.
  - c. One multipurpose room shall be constructed to support a variety of events for up to 25 people. This room shall be located adjacent to the ice rinks for use during rentals and events.
  - d. All multipurpose rooms shall incorporate the use of natural lighting and contain interior glazing for security viewing.
9. Preschool Facility
- a. The building shall include a dedicated pre-school/afterschool facility.
  - b. This facility shall be accommodated with all Illinois Department of Human Services (IDHS) license required elements such as access control and dedicated restroom facilities.
  - c. The preschool shall include four separate rooms each accommodating up to 17 children during preschool/afterschool activities.
  - d. Each room shall meet minimum standards as required by IDHS but shall be no less than 800 square feet in size.
  - e. These rooms shall be designed in a flexible manner to allow evening and weekend use for other community functions including incorporation of adequate storage for pre-school/afterschool furnishings and materials.
  - f. The preschool shall include separate office, restrooms and kitchen facilities.
10. Commercial Kitchen

- a. A commercial kitchen shall be constructed capable of supporting daily use such as lunch service for programs as well as private rental events for up to 300 people. The kitchen will include appropriate equipment and finishes for commercial food service as well as a separate and locked storage area for foodstuffs and supplies.

#### 11. Concession Area

- a. A concession area shall be constructed and include a designated space for seating with flexible tables and chairs.
- b. The concession area shall be located adjacent to the commercial kitchen for concomitant operations.

#### 12. Vending

- a. Vending areas shall be provided at logical locations in the facility and shall include both food and skating supplies such as tape and mouth guards.

#### 13. Administrative Offices

- a. Administrative offices shall be constructed and provide clear viewing of all incoming and exiting facility users as well as direct views to both rinks for security purposes. A security camera system can be used to supplement visual observation needs if required.
- b. The administrative offices shall include all general office functions as well as a registration desk.
- c. The administrative offices shall include a minimum of five private offices for building and program management.
- d. The administrative offices shall include storage for equipment and supplies.

#### 14. Pro Shop

- a. A pro shop shall be constructed and include a separate office for hockey program administration including a separate dressing room for coaching staff.
- b. The pro shop shall include skate rental facilities and storage systems.
- c. The pro shop shall include an area for skate sharpening and associated equipment.

#### 15. Support Facilities

- a. Restrooms shall meet all code requirements and be sufficient to support typical daily operations. A family restroom shall also be provided.
- b. Storage shall be provided throughout the facility at logical locations and be capable of supporting both interior and exterior athletic materials and equipment as well as general materials and equipment for daily activities and rental use. Provision for adequate storage is critical to building operational success and shall not be compromised.
- c. MEP/FP operations space shall be provided as needed to support the facility. These spaces shall be adequately sized for material and equipment storage as well as for access for maintenance activities.
- d. Backup power generator and other related features required to utilize the facility as an emergency shelter and/or heating and cooling center shall be examined and potentially included in the design.

#### 16. Site Improvements

- a. Surface parking for approximately 225 vehicles shall be provided. Use of permeable materials and other sustainable techniques shall be explored for stormwater management.
- b. The east half of the site shall be improved with three exterior artificial turf fields. A variety of sports shall be accommodated on these fields including baseball,

soccer, football and lacrosse. Each field shall include athletic lighting controlled through web based technology.

- c. The existing tennis courts at this facility shall be protected and maintained.
- d. The site shall be provided with appropriate exterior signage to both identify the facility and provide wayfinding to direct users to various athletic fields and park spaces.
- e. The athletic fields shall include display boards to post daily field permits.
- f. The athletic fields shall provide adequate space for movable equipment to be secured off the active field areas.
- g. The athletic fields shall be provided with a weather alert system tied to web based system.
- h. The site shall be provided with appropriate park accommodations to create an attractive, inviting and comfortable environment such as, but not limited to, pedestrian/vehicular circulation, maintenance and delivery access, shaded areas for fans and players, spectator seating, perimeter fencing, site furnishings, drinking fountains, lighting and landscaping.

#### 17. Other Considerations

- a. The site and facility shall minimally receive LEED Silver accreditation.
- b. The facility shall include public charging stations and Wi-Fi throughout the building.
- c. The facility shall include ample lighting including the use of natural daylight where possible to improve ambiance and reduce energy use.
- d. The facility shall include a technologically advanced A/V system for public announcements and general program information including flat screen monitors and display surfaces.
- e. The facility shall include sustainable techniques such as rainwater harvesting for use in irrigation, cooling tower operation and other demonstration activities.
- f. The facility shall include an entry control system for staff areas and programs.
- g. The facility shall utilize highly durable and easily cleaned finishes, furnishings and floor coverings.
- h. The facility shall incorporate provisions for future expansion such as, but not limited to, under-floor duct systems to accommodate future power and data needs.
- i. The facility shall include sound dampening features to moderate noise levels when surrounded by hard surfaces and to acoustically isolate the library from other portions of the building.
- j. The facility shall include zoned HVAC and power.

#### 1.3 Available City of Evanston Data and Assistance includes:

- 1. Schematic Design Documents (attached).
- 2. Phase 1 Environmental Site Assessment (attached).
- 3. Preliminary Geotechnical Subsurface Investigation Report (attached).
- 4. Traffic and Parking Study (attached).
- 5. City of Evanston staff project management.
- 6. Architectural and engineering services through the City's existing contract with WTA and MJMA.
- 7. Payment of City of Evanston permit fees (where required).

## 1.4 General Information

The contract term desired is through December 31, 2020. Please note that each task will be executed by separate contract with interim completion deadlines.

Contact with City personnel in connection with this RFP shall not be made other than as specified in this RFP. Unauthorized contact of any City personnel may be cause for rejection of a proposal.

Prior to the submittal of a proposal, Proposers are advised to carefully examine

- the contract documents
- project scope and work tasks to be accomplished
- specifications
- submittal requirements
- insurance requirements and required documentation

Proposers are advised to become thoroughly familiar with all conditions, instructions and specifications governing this RFP. Proposals shall be made in accordance with these instructions. Proposals shall be submitted on the forms provided by the City

The City will not be liable in any way for any costs incurred by respondents in replying to this Request for Proposal.

## 2.0 SCOPE OF SERVICES

Respondents may elaborate or add to the proposed scope of work to ensure a comprehensive project scope is prepared; however larger is not necessarily better regarding either the CM responsibilities or the project itself.

### **Task 1 – Preconstruction Responsibilities**

The Construction Manager shall review available information, meet with the Owner, Architect and their engineering sub-consultants (MEP/FP, Structural, Civil, etc.) periodically during the preconstruction phase to remain informed of decisions being made and advise the design team on matters relating to constructability, cost control and scheduling. Minimally work shall include:

1. Become familiar with the project through regular meetings with the Owner, and the Architect.
2. Participate in the budgeting process by performing estimating, scheduling and value engineering analysis as required. There will be no set cap on the amount of requests for these studies however all study costs must be included in the construction manager's not to exceed fee.
3. Prepare detailed Estimated Costs of Construction at all major milestones (design development, 60% construction documents, and 100% construction documents). Each estimate shall be completed in no more than three (3) weeks.
4. Develop reporting systems, and provide a project budget, cash flow projections, and project status reports.
5. Optimize construction feasibility and efficiency of the design by evaluating labor and material availability, recommending alternate methods and materials, identifying long lead items for pre-purchase, and identifying necessary survey and consultant

information.

6. Prepare for the bidding process by providing a pre-qualified subcontractor bid list to the Owner and Architect for approval (this list shall not limit the Owner's right to expand the list if desired and consented to by the CM), developing bidders' interest in the project, establishing a bidding schedule, and coordinating with the City of Evanston's M/W/EBE and LEP program requirements as well as other relevant City of Evanston general conditions.
7. Develop with the Owner and Architect strategies for procurement of early trades; for example foundation, super structure, and HVAC systems.
8. Work with the Owner and Architect to develop construction documents suitable for filing with the permitting agencies at the earliest possible date.
9. Advise the Owner and Architect on project phasing, sequencing, and procurements. Prepare an overall construction schedule in Gantt-chart form and showing all phases of the project. Identify a critical path for long lead items, and any methods or measures that will speed the overall schedule without sacrificing quality. Update the construction schedule regularly to reflect ongoing project decisions.
10. Consider strategies for logistics and site safety planning. Determine areas for deliveries and staging, vertical hoisting, etc.
11. Advise the Owner and Architect on the most appropriate contract procurement methods for the construction of the building within the City's purchasing requirements. Provide a construction management plan addressing the items noted above and update it periodically throughout the project.

## **Task 2 – Construction Phase Responsibilities**

For the Construction Phase, the Construction Manager will enter into a Negotiated Guaranteed Maximum Price (GMP) contract with the Owner. The Construction Manager's role will then become that of a General Contractor and perform the work identified in the construction documents and as detailed below.

The Construction Phase will begin with an authorization from the City to proceed with bidding and will continue through completion of construction, punch list, and closeout of the Project. A warranty period for all work performed by the Construction Manager or trade contractors under contract with him of no less than one year from the date of Architect's certification of substantial completion will also be required. Not less than 6 months prior to the Warrantee period expiration date, the Construction Manager will provide a punch list of deficient items prior to final release. Failure to provide this will be considered a material breach – see termination section.

Anticipated services include the following:

1. Responsibility for the subcontractor selection process utilizing the list of pre-qualified subcontractors approved by the Owner (see section above about City reserving the right to add to the list) and Architect; this will include conducting a pre-bid conference, distributing plans, receiving and analyzing bids, making recommendations to the Owner, and negotiating and awarding contracts.
2. Responsibility for managing the work to be performed by all subcontractors by providing competent project management and field supervisory personnel that keep all contracts on time and under budget at each step of the task being completed.
3. Provide contracts with all sub-contractors including penalties for failure to perform

based on the schedule determined by the CM, City Policies and Procedures regarding LEP and MWEBE and any other local ordinance, statute or regulation with jurisdiction regarding the project.

4. In general the Construction Manager will:
  - a. Provide qualified, full-time field personnel on-site that communicate fluently with each other, the Owner and the Architect, both verbally and in writing during all phases of the construction project. Any barrier to communication is the responsibility of the CM to remedy with no additional cost to the owner once subcontractors and costs are established.
  - b. Establish on-site organization and lines of authority.
  - c. Coordinate the work of all trades to ensure the schedule is maintained.
  - d. Schedule and conduct weekly project meetings for discussion of progress, procedures, issues, schedules and changes. Issue meeting minutes and action items for follow-up.
  - e. Provide all supervision, labor, materials, equipment and tools not provided by subcontractors or the Owner, which are necessary for completion of the Project.
  - f. Establish procedures for, and maintain coordination among, the Owner and his Representative, the Architect, subcontractors, and outside authorities having jurisdiction over the Project. See comment above about compliance and penalty provisions.
  - g. Coordinate necessary aspects of the work with local municipal authorities, local schools, governmental agencies, and utilities as needed.
  - h. Ensure that all subcontractor supervision, personnel, equipment and materials, as well as all testing by others, are adequate and in conformance with drawings, specifications, contract documents, and applicable building codes.
  - i. Receive, review, and deliver all shop drawings, brochures, material samples, as-built drawings, operating manuals, and instructions, warranties, keys, and maintenance stocks; also, maintain on site a complete library of all contract documents, approved shop drawings and approved material samples in paper, electronic, and physical sample form.
  - j. Review and consolidate all applications for payment, submit to the Architect prior to issuance for review, bill the Owner in accordance with established procedures, less 10% retainage, and make prompt payment to all subcontractors; also, maintain cost accounting records on authorized work performed under unit costs, actual costs for labor and material, or other bases requiring accounting records and afford the Owner access to these records for a period of three years following final payment.
  - k. Receive, check, and forward to the Owner as part of the monthly applications for payment conditional lien waivers from each subcontractor/vendor included.
  - l. Receive, check, and forward to the Owner all releases of lien required prior to issuance of final certificate of completion and final payment to subcontractors.
  - m. Submit certified payroll on a monthly basis in accordance with the State of Illinois' prevailing wage requirements.
  - n. Meet or exceed the City's goal of minority, women and Evanston based business (M/W/EBE) participation on the project.
  - o. Meet or exceed the City's Local Employment Program (LEP) requirements. While MWEBE programs initiatives are goal oriented, the LEP program is a legally binding agreement. The CM is completely accountable for the



adherence to LEP requirements including the acknowledgement that up to a 1% penalty of all project costs may be assessed for failure to meet LEP requirements.

- p. Review and make recommendations to the Owner on all proposed changes; also, receive and review change order requests from subcontractors, negotiate costs of change orders, and ensure that all approved change orders are satisfactorily completed. Provide back up for all labor, material and any other costs for change orders.
- q. Determine substantial completion of the work with consent of the Architect and Owner.
- r. Provide LEED documents and track LEED credits (construction waste, recycled content, etc.).
- s. Complete project closeout, including:
  - i. Prepare for the Architect a pre-punch list of incomplete or unsatisfactory items and schedule their completion dates. Complete all punch list work no later than six months after substantial completion is achieved.
  - ii. Direct the checkout of utilities, operating systems, and equipment for readiness and assist in their initial start-up and testing by the trade contractors.
  - iii. Provide complete commissioning of all building systems and equipment including training, a walk-through, and explanation of all mechanical and electrical systems for the Building Manager and for the Owner's maintenance personnel.
  - iv. Provide all maintenance manuals, warranties, spare parts, etc.
  - v. Prepare certificates of substantial and final completion, and obtain a Temporary and Final Certificates of Occupancy.
  - vi. Deliver all required project closeout documents to the Owner.
  - vii. Prepare as-built documents.

### **3.0 INSURANCE**

Consultant shall carry and maintain at its own cost with such companies as are reasonably acceptable to City all necessary liability insurance (which shall include as a minimum the requirements set forth below) during the term of this Agreement, for damages caused or contributed to by Consultant, and insuring Consultant against claims which may arise out of or result from Consultant's performance or failure to perform the Services hereunder.

The consultant must provide an insurance certificate naming the City of Evanston as an additional insured as well as a copy of the consultant's insurance policy, including endorsements. The certificate will provide a variety of insurances including:

- comprehensive general liability - \$5,000,000 combined single limit for each occurrence for bodily injury and property damage – designating the City as Additional Insured
- Workers Compensation - Statutory Limits
- Automobile Liability - \$1,000,000 per occurrence for all claims arising out of bodily injuries or death and property damages.
- errors and omissions or professional liability insurance - \$3,000,000

The surety and the insurance company must have not less than an A+ rating from the Alfred M. Best Co., Inc. and be approved by the City of Evanston.

Consultant's certificate of insurance shall contain a provision that the coverage afforded under the policy(s) will not be canceled or reduced without thirty (30) days prior written notice (hand delivered or registered mail) to City.

#### **4.0 SUBMITTAL REQUIREMENTS**

Responses to this Request shall be in one volume. Any firm brochures and/or information pertaining to the qualifications of the firm and/or team may be submitted, but must be included in a single volume. Applicant firms must submit their responses as follows:

1. Paper copies-- ten (10) hardcopies, one (1) unbound original and an electronic copy on a flash/USB drive

Submittals must be forwarded in sealed envelopes clearly marked on the OUTSIDE with the following:

- RFP name and number
- Name and address of Firm
- Date and time of RFP deadline

ANY PROPOSALS RECEIVED AFTER THE SUBMITTAL DEADLINE, WILL BE RETURNED TO THE PROPOSER UNOPENED. It is the sole responsibility of the proposer to insure that his or her proposal is delivered by the stated time. Mailed proposals, which are delivered after the specified time, will not be accepted regardless of post marked time on the envelope. THE CITY IS NOT RESPONSIBLE FOR MISDIRECTED PACKAGES.

##### **A. Cover Letter**

The cover letter (maximum 3 pages) will include the following:

- introduction of firm signed by an authorized Principal of the firm
- name of firm
- address of firm
- phone number of the firm submitting the proposal
- include the name and signature of an authorized binding official who is authorized to answer questions regarding the firm's proposal

##### **B. Qualifications and Experience of Firm and/or Team**

- All respondents shall complete Exhibit N to describe other contracts (at least 5, but no more than 10) similar in scope, size or discipline to the required services described herein, performed or undertaken within the past five years.
- The respondent must provide references, including name, address and telephone number of a contact person for each project identified and described.
- Indicate commencement dates, duration and type of operation.
- Provide a list of all Municipal clients in Illinois.

- Respondents shall provide specific examples and expertise related to design and construction of libraries.
- Respondents shall provide specific examples and expertise related to design and construction of ice rink facilities.

**C. Construction Manager(s) and Key Project Personnel**

Clearly identify the professional staff person(s) who would be assigned as your Construction Manager and key project personnel. The proposal should indicate the abilities, qualifications and experience of these individuals and provide resumes.

**D. Project Approach**

For each of the tasks outlined in the Scope of Services, provide a narrative describing the firm's understanding of the task and indicate the following:

- Approach used to complete the task
- Information needed from the City
- Issues to be considered in completion
- Team member(s) who will complete the task. If more than one, clearly indicate the responsibility of each team member
- Estimated level of effort in hours broken down by subtasks and each team member's effort
- Relevant standards adhered to and certifications held by team members

**E. Fees**

Provide a not-to-exceed cost for Task 1 and an estimated cost for Task 2 based on the Schematic Design Documents by completing the Proposal Cost Table (Exhibit O) included with this RFP. Break down all costs by task and labor category and break out reimbursable direct costs separately. Proposals must list the salary cost multiplier for all labor hours.

**F. Completeness of Proposal Statement**

Provide a table of contents. Respond to all items listed in the submission requirements section and provide all other documents requested.

**G. Contract**

The City intends to utilize AIA Document A133-2009 (Standard Form of Agreement Between Owner and Construction Manager as Constructor where the basis of payment is the Cost of the Work Plus a Fee with a Guaranteed Maximum Price), AIA Document A201-2007 (General Conditions of the Contract for Construction), and City of Evanston supplemental conditions for this project. Respondents shall indicate in Exhibit P if there are any exceptions to the proposed agreement that would prevent your firm from executing it. The City shall not consider or negotiate regarding exceptions submitted at any time after the submission of the Proposal.

**H. Contract Forms**

Executed copies of **all forms** included as Exhibits to this RFP must be submitted with the proposal.

## **5.0 ADDITIONAL SUBMISSION REQUIREMENTS**

- A. Bid Bond: Respondents shall submit with their proposal a bid bond for 5% of the estimated Task 2 Contract Amount. A letter of credit may be furnished in lieu of a bid bond only if the following conditions are met: 1) An irrevocable letter of credit must be obtained from an accredited bank which shall include an agreement that the bank will honor a demand by the City for payment due to Plaintiff failure to complete the project. 2) An irrevocable letter of credit must be in writing and signed by an authorized representative of the bank. 3) The irrevocable letter of credit must expressly state that it is irrevocable until the bid has been awarded. 4) The letter of credit must be for the percentage specified in the bid documents. The City may reject the use of an irrevocable letter of credit if the financial soundness of the issuing bank is found to be unacceptable.
- B. Performance, Material and Labor Bond: The successful Construction Manager shall, within ten (10) calendar days after award of Task 2, furnish a performance bond in the amount of one hundred and ten percent (110%) of the contract amount from insurance companies having not less than A+ Policyholders Rating from the most recent Alfred M. Best and Co., Inc. listing available. Certification of the insurance company's rating shall be provided prior to contract implementation and quarterly thereafter until contract completion. Should such rating fall below the required A+ level during performance of the contract, it will be the Construction Manager's responsibility to notify the City and provide a new bond from an insurance company whose rating meets the City's requirements. In the event that the Construction Manager fails to furnish a performance bond in said period of ten (10) calendar days after award of Task 2, the City may withdraw its award and retain the Construction Manager's deposit as liquidated damages and not as a penalty.

## **6.0 M/W/EBE GOALS**

The City has a goal of 25% of the contract amount for the participation and utilization of Minority-Owned, Women-Owned, and Evanston-based businesses (M/W/EBEs) in completing a portion of the services required by the City. All respondents must submit a statement of the proposed involvement of M/W/EBEs in completing a portion of the required services. Provide a copy of the certification for M/W/EBEs that will assist in achieving the M/W/EBE goal with your submittal as well as the appropriate M/W/EBE forms or Request for Waiver. Any questions regarding M/W/EBE compliance should be submitted in writing to Sharon A. Johnson, Business Workforce Compliance Coordinator at [shjohnson@cityofevanston.org](mailto:shjohnson@cityofevanston.org) or Tammi Nunez Purchasing Manager at [tnunez@cityofevanston.org](mailto:tnunez@cityofevanston.org).

## **7.0 LOCAL EMPLOYMENT PROGRAM REQUIREMENTS**

In an effort to increase hiring of economically disadvantaged Evanston residents on certain City construction projects, the contractor shall comply with the provisions of the City of Evanston's Local Employment Program Ordinance (LEP) set forth in Section 1-17-1 (C) of the Evanston City Code. The intent of the LEP is to have Evanston residents employed at the construction site as laborers, apprentices and journeymen in such trades as electrical, HVAC, carpenters, masonry, concrete

finishers, truck drivers and other construction occupations necessary for the project. Any questions regarding LEP compliance should be submitted in writing to Tammi Nunez at [tnunez@cityofevanston.org](mailto:tnunez@cityofevanston.org).

**NOTE: CITY OF EVANSTON ORDINANCE 60-O-14 AMENDMENT LOCAL EMPLOYMENT PROGRAM (LEP) available on the City website at <http://www.cityofevanston.org/business/business-diversity/>**

## **8.0 EVALUATION CRITERIA**

The City will select the successful firm through an evaluation process based on the firm meeting the specifications which are outlined in this RFP. A review committee will review in detail all proposals that are received. During the evaluation process, the City may require a Proposer's representative to answer questions with regard to the proposal and/or make a formal presentation to the review committee. The review committee will make a recommendation to award the contract based on the criteria set forth below. This contract will be forwarded to the City Council for final approval.

The evaluation criteria listed below will be used in the selection of the successful Proposer.

- A. Qualifications and Expertise
- B. Project Approach
- C. Price
- D. Organization and Completeness of Proposal
- E. Willingness to Execute the Agreement
- F. M/W/EBE Participation

## **9.0 SELECTION PROCESS**

The City will select a firm on the basis of the responsiveness of the proposal to the RFP submittal requirements, the evaluation criteria stated above and the demonstrated willingness to execute an acceptable written contract. The City reserves the right to reject any or all proposals, and to request written clarification of proposals and supporting materials from the Proposer.

While it is the intent of the City to award a single firm, the City reserves the right to award in part or in whole and to select multiple firms and/or individuals, depending on whichever decision is deemed to be most advantageous to the City.

Responses may be rejected if the firm fails to perform any of the following:

- A. Adhere to one or more of the provisions established in this Request for Proposal.
- B. Demonstrate competence, experience, and the ability to provide the services described in this Request for Proposal.
- C. Submit a response on or before the deadline and complete all required forms.
- D. To fulfill a request for an oral presentation.
- E. To respond to a written request for additional information.

Discussions and/or interviews may be conducted with responsible firms that have submitted proposals in order to clarify certain elements. All proposals shall be afforded fair and equal treatment with respect to any opportunity for clarification. In conducting discussion, there shall be no disclosure of information derived from proposals submitted by competing firms. The selection shall be done by the City's review committee and will be recommended to the City Council for final approval.

If the City is unable to reach any sort of agreement with the selected firm, the City will discontinue negotiations with the selected firm and begin negotiations with the firm ranked second and so on until agreement is reached.

The firm to be recommended to the City Council will be the one whose proposal is determined to be the most advantageous to the City in consideration of price and all other evaluation factors which are set forth in this Request for Proposal No other factors or criteria not listed in this RFP shall be used in the evaluation.

## 10.0 PROPOSED SCHEDULE

The tentative schedule for this RFP and project is as follows:

1. RFP issued ..... October 5, 2017
2. Non-mandatory Pre-Proposal meeting..... October 12, 2017
3. Last day to submit questions ..... October 19, 2017
4. Final Addendum issued ..... October 26, 2017
5. RFP Submission Due Date ..... November 7, 2017
6. Short listed firms interviewed ..... week of November 27, 2017
7. Consultant selection, negotiation ..... week of December 4, 2017
8. City Council Award of Contract ..... January 8, 2018
9. Task 1 – Completion ..... March 30, 2018
10. Task 2a – New Building Occupancy ..... August 15, 2019
11. Task 2b – Existing Building Demolition ..... September 30, 2019
12. Task 2c – Athletic Field Occupancy ..... June 30, 2020

## 11.0 QUESTIONS REGARDING RFP

All questions related to this RFP should be submitted in writing to Jillian Ostman, Purchasing Specialist at [jostman@cityofevanston.org](mailto:jostman@cityofevanston.org) with a copy to Stefanie Levine, Senior Project Manager at [slevine@cityofevanston.org](mailto:slevine@cityofevanston.org).

## 12.0 GENERAL TERMS AND CONDITIONS

### A. Confidentiality

In connection with this Agreement, City may provide Consultant with information to enable Consultant to render the Services hereunder, or Consultant may develop confidential information for City. Consultant agrees (i) to treat, and to obligate Consultant's employees to treat, as secret and confidential all such information whether or not identified by City as confidential, (ii) not to disclose any such information or make available any reports, recommendations and /or conclusions which Consultant may make for City to any person, firm or corporation or use the same in any manner whatsoever without first obtaining City's written approval, and (iii) not to disclose to City any information obtained by Consultant on a confidential basis

from any third party unless Consultant shall have first received written permission from such third party to disclose such information.

Pursuant to the Illinois Freedom of Information Act, 5 ILCS 140/7(2), records in the possession of others whom the City has contracted with to perform a governmental function are covered by the Act and subject to disclosure within limited statutory timeframes (five (5) working days with a possible five (5) working day extension). Upon notification from the City that it has received a Freedom of Information Act request that calls for records within the Consultant's control, the Consultant shall promptly provide all requested records to the City so that the City may comply with the request within the required timeframe. The City and the Consultant shall cooperate to determine what records are subject to such a request and whether or not any exemptions to the disclosure of such records, or part thereof, is applicable.

The Purchasing Specialist will endeavor to advise the firm of any request for the disclosure of the material so marked with "TRADE SECRET", "CONFIDENTIAL", or "PROPRIETARY", and give the firm or other submitting party the opportunity to seek a court order to protect such materials from disclosure. If the requested material was submitted by a party other than the firm, then the firm shall be solely responsible for notifying the submitting party of the request. The City's sole responsibility is to notify the firm of the request for disclosure, and the City shall not be liable for any damages resulting out of such disclosure, whether such disclosure is deemed required by law, by an order of court or administrative agency, or occurs through inadvertence, mistake, negligence on the part of the City or its officers, or employees.

**B. Withdrawal of Proposal**

Proposals may be withdrawn prior to the submittal deadline. Withdrawal may be attained by written request; however, no offer can be withdrawn within the ninety (90) day period which occurs after the time is set for closing. Proposers who withdraw their proposals prior to the designated date and time may still submit another proposal if done in accordance with the proper time frame.

**C. Exceptions to Specifications**

Exceptions to these specifications shall be listed and explained on a separate page titled "Exceptions to Specifications", which shall be prepared by the Proposer. This page shall then be attached to these documents and submitted at the same time as the proposal. Each exception must refer to the page number and paragraph to which it is relevant. The nature and reasoning of each exception shall be explained in its entirety. Any exceptions to these specifications may be cause for rejection of the proposal.

**D. Hold Harmless**

The contractor agrees to hold harmless the City of Evanston and all of its agents, servants, and employees against any and all lawsuits, claims, demands, liabilities, losses, and/or expenses; including court costs and attorneys' fees on account of injury to any person, or any death resulting from

such injury, or any damage to property which may have arisen from work specifically related to the contract and/or project.

**E. Addenda**

Any and all changes to these documents are valid only if they are included via written addendum to all respondents. Each respondent should acknowledge receipt of any addenda by indicating same in their proposal submission. Each respondent acknowledging receipt of any addenda is responsible for the contents of the addenda and any changes to the proposal therein. Failure to acknowledge any addenda may cause the proposal to be rejected. Addenda information is available over the internet at [City of Evanston Notices & Documents](#) or [www.demandstar.com](http://www.demandstar.com), or by contacting the Purchasing Office, 847-866-2935.

**F. Term**

The contract term is until December 31, 2019. The City may terminate a contract for either cause or convenience. The City may extend this contract at proposal cost levels for 2019 into 2020 due to weather related delays, acts of God or Regulatory delays beyond the City's control. The City and CM will negotiate the amount of 2019 costs that may be deferred into 2020 due to the above delays.

**G. Non-Appropriation of Funds**

The City of Evanston reserves the right to terminate in whole or in part of the contract in the event that sufficient funds to complete the contract are not appropriated by The City of Evanston's City Council.

**H. Property of the City**

All discoveries and documents produced as a result of any service or project undertaken on behalf of the City of Evanston shall become the property of the City.

**I. Payment Terms**

During Task 1, the CM shall submit invoices detailing the services provided, project, professional staff, and hours. During Task 2, payments shall be made in accordance with the AIA contract and the Local Government Prompt Payment Act. Please note that failure to provide a detailed invoice could result in delay of payment and include termination of any agreement. All payments during Task 2 will be subject to a 10% retainage to be paid upon completion of the project.

**J. Disclosures and Potential Conflicts of Interest**

The City of Evanston's Code of Ethics prohibits public officials or employees from performing or participating in an official act or action with regard to a transaction in which he has or knows he will thereafter acquire an interest for profit, without full public disclosure of such interest. This disclosure requirement extends to the spouse, children and grandchildren, and their spouses, parents and the parents of a spouse, and brothers and sisters and their spouses.



To ensure full and fair consideration of all proposals, the City of Evanston requires all Proposers including owners or employees to investigate whether a potential or actual conflict of interest exists between the Proposer and the City of Evanston, its officials, and/or employees. If the Proposer discovers a potential or actual conflict of interest, the Proposer must disclose the conflict of interest in its proposal, identifying the name of the City of Evanston official or employee with whom the conflict may exist, the nature of the conflict of interest, and any other relevant information. The existence of a potential or actual conflict of interest does NOT, on its own, disqualify the disclosing Proposer from consideration. Information provided by Proposers in this regard will allow the City of Evanston to take appropriate measures to ensure the fairness of the proposal process.

The City requires all Proposers to submit a certification, enclosed with this RFP, that the Proposer has conducted the appropriate investigation and disclosed all potential or actual conflicts of interest.

#### **K. Protests**

Any actual or prospective Proposer, who is aggrieved in connection with the solicitation or award of a contract, may protest to the Purchasing Office. The protest shall be submitted in writing within ten (10) calendar days after such aggrieved person knows or should have known of the facts giving rise thereto.

- The Proposer shall submit any protests or claims regarding this solicitation to the Purchasing Office.
- A pre-bid protest must be filed five (5) days before the bid opening or proposal submittal.
- A pre-award protest must be filed no later than ten (10) days after the bid opening date or proposal deadline.
- A post-award protest must be filed no later than ten (10) days after the award of the Contract.

All claims by a Proposer against the City relating to a contract shall be submitted in writing to the Purchasing Specialist. The City will only consider protests that are properly and timely submitted.

All protests or claims must set forth the name and address of the protester, the contract number, the grounds for the protest or claim, and the course of action that the protesting party desires the Purchasing Specialist to take. Statements shall be sworn and submitted under penalty of perjury.

#### **L. Authority To Resolve Protests And Contract Claims**

*Protests:* The Purchasing Specialist shall have the authority to consider and resolve a protest of an aggrieved Proposer, actual or prospective, concerning the solicitation or award of a contract. The City shall issue a written decision and that decision is final.

*Contract Claims:* The Purchasing Specialist, after consulting with Corporation Counsel, shall have the authority to resolve contract claims, subject to the approval of the City Manager or City Council, as applicable, regarding any settlement that will result in a change order or contract modification.

Each Proposer, by submitting a response to this RFP, expressly recognizes the limitations on its rights to protest provided in this Section and expressly waives all other rights and remedies and agrees that the decision on the protest is final and conclusive. If a Proposer disregards, disputes or does not follow the exclusive protest remedies provided in this Section, it shall indemnify and hold the City and its officers, employees, agents and consultants harmless from and against all liabilities, fees and costs, including legal and consultant fees and costs, and damages incurred or suffered as a result of such Proposer's actions. Each Proposer, by submitting a response to this RFP, shall be deemed to have irrevocably and unconditionally agreed to this indemnity obligation.

#### **M. Litigation**

For purposes of this Section, the following terms are defined as follows:

"issue" means any prior or pending litigation or investigation, either civil or criminal, or any governmental agency action or proceeding (the "issue"), which may affect the performance of the services to be rendered herein. For purposes of this Section, an "issue" shall also include any criminal, civil, or administrative penalty or finding imposed against any covered individual. An issue occurring within seven (7) years of the date preceding the date of the Proposer's response shall be disclosed by the Proposer.

"covered individual" means any principal, president, managing partner, or vice-president, affiliated in anyway with the Firm, and the Firm's employees or subcontractors.

All proposers shall identify and describe with particularity any issue. The City, and not Proposer, has the sole discretion to determine whether an issue may affect the performance of the services. Failure of any Proposer to comply with this mandatory obligation shall, at the City's sole discretion, result in the Proposer's response being deemed non-responsive and not responsible. Failure of any Proposer to comply with the obligation specified herein may result in the voiding any subsequent contract award to Proposer if the City discovers upon the exercise of its customary due diligence that Proposer failed to comply with the mandatory obligation in this Section. The City reserves all rights to take any other actions in the case of a Proposer's non-compliance with this Section.

#### **N. Subcontractors**

If any firm submitting a proposal intends on subcontracting out all or any portion of the engagement, that fact, and the name of the proposed subcontracting firm(s) must be clearly disclosed in the proposal. Following the award of the contract, no additional subcontracting will be allowed without the prior written consent of the City of Evanston.

**O. Contact with City Personnel**

All Proposers are prohibited from making any contact with the City Manager, City Council, or any other official or employee of the City with regard to the Project, other than in the manner and to the person(s) designated herein. The Purchasing Specialist reserves the right to disqualify any Proposer found to have contacted City Personnel in any manner with regard to the Project. Additionally, if it is determined that the contact with City Personnel was in violation of any provision of 720 ILCS 5/33EE, the matter may be referred to the Cook County State's Attorney for review and prosecution.

**P. Costs Incurred**

The City of Evanston assumes no responsibility or liability for costs incurred by the Proposer prior to the execution of a contract. This includes costs incurred by the Proposer as a result of preparing a response to this RFP.

**Exhibit A**

**DISCLOSURE OF OWNERSHIP INTERESTS**

The City of Evanston Code Section 1-18-1 *et seq.* requires all persons (APPLICANT) seeking to do business with the City to provide the following information with their proposal. Every question must be answered. If the question is not applicable, answer with "NA".

APPLICANT NAME: \_\_\_\_\_

APPLICANT ADDRESS: \_\_\_\_\_

TELEPHONE NUMBER: \_\_\_\_\_

FAX NUMBER: \_\_\_\_\_

APPLICANT is (**Check One**)

- Corporation
- Partnership
- Sole Owner
- Association

Other ( ) \_\_\_\_\_

Please answer the following questions on a separate attached sheet if necessary.

**SECTION I - CORPORATION**

1a. Names and addresses of all Officers and Directors of Corporation.

\_\_\_\_\_  
\_\_\_\_\_  
\_\_\_\_\_

1b. **(Answer only if corporation has 33 or more shareholders.)**

Names and addresses of all those shareholders owning shares equal to or in excess of 3% of the proportionate ownership interest and the percentage of shareholder interest. (Note: Corporations which submit S.E.C. form 10K may substitute that statement for the material required herein.)

\_\_\_\_\_  
\_\_\_\_\_  
\_\_\_\_\_

- 1c. **(Answer only if corporation has fewer than 33 shareholders.)**  
Names and addresses of all shareholders and percentage of interest of each herein.  
(Note: Corporations which submit S.E.C. form 10K may substitute that statement for the material requested herein.)

---

---

---

**SECTION 2 - PARTNERSHIP/ASSOCIATION/JOINT VENTURE**

- 2a. The name, address, and percentage of interest of each partner whose interests therein, whether limited or general, is equal to or in excess of 3%.

---

---

---

- 2b. Associations: The name and address of all officers, directors, and other members with 3% or greater interest.

---

---

---

**SECTION 3 - TRUSTS**

- 3a. Trust number and institution.

---

- 3b. Name and address of trustee or estate administrator.

---

---

- 3c. Trust or estate beneficiaries: Name, address, and percentage of interest in total entity.

---

**SECTION 4 - ALL APPLICANTS - ADDITIONAL DISCLOSURE**

4a. Specify which, if any, interests disclosed in Section 1, 2, or 3 are being held by an agent or nominee, and give the name and address of principal.

---

---

---

4b. If any interest named in Section 1,2, or 3 is being held by a "holding" corporation or other "holding" entity not an individual, state the names and addresses of all parties holding more than a 3% interest in that "holding" corporation or entity as required in 1(a), 1(b), 1(c), 2(a), and 2(b).

---

---

---

4c. If "constructive control" of any interest named in Sections 1,2, 3, or 4 is held by another party, give name and address of party with constructive control. ("Constructive control" refers to control established through voting trusts, proxies, or special terms of venture of partnership agreements.)

---

---

---

I have not withheld disclosure of any interest known to me. Information provided is accurate and current.

\_\_\_\_\_  
Date

\_\_\_\_\_  
Signature of Person Preparing Statement

\_\_\_\_\_  
Title

ATTEST: \_\_\_\_\_  
Notary Public

(Notary Seal)

Commission Expires: \_\_\_\_\_

**Exhibit B**

**ADDITIONAL INFORMATION SHEET**

Proposal Name: \_\_\_\_\_

Proposal Number #: \_\_\_\_\_

Company Name: \_\_\_\_\_

Contact Name: \_\_\_\_\_

Address: \_\_\_\_\_

City, State, Zip: \_\_\_\_\_

Telephone/FAX: # \_\_\_\_\_

E-mail: \_\_\_\_\_

**Comments:** \_\_\_\_\_

\_\_\_\_\_

\_\_\_\_\_

\_\_\_\_\_

\_\_\_\_\_

\_\_\_\_\_

\_\_\_\_\_

**Exhibit C**

**CONFLICT OF INTEREST FORM**

\_\_\_\_\_, hereby certifies that it has conducted an investigation into whether an actual or potential conflict of interest exists between the bidder, its owners and employees and any official or employee of the City of Evanston.

Proposer further certifies that it has disclosed any such actual or potential conflict of interest and acknowledges if bidder/Proposer has not disclosed any actual or potential conflict of interest, the City of Evanston may disqualify the bid/proposal.

\_\_\_\_\_  
(Name of Bidder/Proposer if the Bidder/Proposer is an Individual)  
(Name of Partner if the Bidder/Proposer is a Partnership)  
(Name of Officer if the Bidder/Proposer is a Corporation)

The above statements must be subscribed and sworn to before a notary public. Subscribed and Sworn to this \_\_\_\_\_ day of \_\_\_\_\_, 20\_\_.

\_\_\_\_\_  
Notary Public

*Failure to complete and return this form may be considered sufficient reason for rejection of the bid / proposal*



**Exhibit D**

**ACKNOWLEDGEMENT OF UNDERSTANDING**

**THE SECTION BELOW MUST BE COMPLETED IN FULL AND SIGNED**

---

The undersigned hereby certifies that they have read and understand the contents of this solicitation and attached service agreements, and agree to furnish at the prices shown any or all of the items above, subject to all instructions, conditions, specifications and attachments hereto. Failure to have read all the provisions of this solicitation shall not be cause to alter any resulting contract or to accept any request for additional compensation. By signing this document, the Proposer hereby certifies that they are not barred from bidding on this contract as a result of bid rigging or bid rotating or any similar offense (720 ILCS S/33E-3, 33E-4).

---

<b>Authorized Signature:</b> _____	<b>Company Name:</b> _____
<b>Typed/Printed Name:</b> _____	<b>Date:</b> _____
<b>Title:</b> _____	<b>Telephone Number:</b> _____
<b>Email:</b> _____	<b>Fax Number:</b> _____

**Exhibit E**

**ANTI-COLLUSION AFFIDAVIT AND PROPOSER'S CERTIFICATION**

\_\_\_\_\_, being first duly sworn,  
deposes and says that he is \_\_\_\_\_  
(Partner, Officer, Owner, Etc.)

of \_\_\_\_\_  
(Proposer)

The party making the foregoing proposal or bid, that such bid is genuine and not collusive, or sham; that said bidder has not colluded, conspired, connived or agreed, directly or indirectly, with any bidder or person, to put in a sham bid or to refrain from bidding, and has not in any manner, directly or indirectly, sought by agreement or collusion, or communication or conference with any person; to fix the bid price element of said bid, or of that of any other bidder, or to secure any advantage against any other bidder or any person interested in the proposed contract.

The undersigned certifies that he is not barred from bidding on this contract as a result of a conviction for the violation of State laws prohibiting bid-rigging or bid-rotating.

\_\_\_\_\_  
(Name of Bidder if the Bidder is an Individual)  
(Name of Partner if the Bidder is a Partnership)  
(Name of Officer if the Bidder is a Corporation)

The above statements must be subscribed and sworn to before a notary public.

Subscribed and Sworn to this \_\_\_\_\_ day of \_\_\_\_\_, 20\_\_

\_\_\_\_\_  
Notary Public

Commission Expires: \_\_\_\_\_

*Failure to complete and return this form may be considered sufficient reason for rejection of the bid.*

## Exhibit F

### **CITY OF EVANSTON M/W/EBE POLICY**

A City of Evanston goal is to provide contracting and subcontracting opportunities to Minority Business Enterprises, Women Business Enterprises, and Evanston Business Enterprises. The goal of the Minority, Women and Evanston Business Enterprise Program (M/W/EBE) is to assist such businesses with opportunities to grow. To assist such growth, the City's goal is to have general contractors utilize M/W/EBEs to perform no less than 25% of the awarded contract.

Firms bidding on projects with the City must work to meet the 25% goal or request a waiver from participation. It is advised that bidders place advertisements requesting subcontractors and that they email or contact individual firms that would be appropriate to partner in response to the project. For samples of possible advertisements, see the City of Evanston's Business Diversity Section [http://www.cityofevanston.org/business/business-diversity/\(Sample Advertisement\)](http://www.cityofevanston.org/business/business-diversity/(Sample%20Advertisement)). If you request a paper copy of the additional documents, it will be available free of charge from the Purchasing Office, 2100 Ridge Road Suite 4200, Evanston, IL 60201.

If a bidder is unable to meet the required M/W/EBE goal, the Bidder must seek a waiver or modification of the goal on the attached forms. Bidder must include:

1. A narrative describing the Bidder's efforts to secure M/W/EBE participation prior to the bid opening.
2. Documentation of each of the assist agencies that were contacted, the date and individual who was contacted, and the result of the conversation (see form)
3. A letter attesting to instances where the bidder has not received inquiries/proposals from qualified M/W/EBEs
4. Names of owners, addresses, telephone numbers, date and time and method of contact of qualified M/W/EBE who submitted a proposal but were not found acceptable.
5. Names of owners, addresses, telephone numbers, date and time of contact of at least 15 qualified M/W/EBEs the bidder solicited for proposals for work directly related to the Bid prior to the bid opening (copies must be attached).

If a bidder is selected with a Subcontractor listed to meet the M/W/EBE goal, a "monthly utilization report" will be due to the City prior to each payment being issued to the Contractor. This report will include documentation of the name of the firm hired, the type of work that firm performed, etc. Should the M/W/EBE not be paid according to the schedule proposed in this document, the City reserves the right to cancel the contract. Examples of this monthly form can be found on the City's website: [http://www.cityofevanston.org/business/business-diversity/\(MWEBE Monthly Utilization Report\)](http://www.cityofevanston.org/business/business-diversity/(MWEBE%20Monthly%20Utilization%20Report)).

**Exhibit G**

**M/W/EBE PARTICIPATION COMPLIANCE FORM**

I do hereby certify that

\_\_\_\_\_ (Name of firm) intends to participate as a Subcontractor or General Contractor on the project referenced above.

This firm is a (check only one):

- \_\_\_\_\_ Minority Business Enterprise (MBE), a firm that is at least 51% managed and controlled by a minority, certified by a certifying agency within Illinois.
- \_\_\_\_\_ Women’s Business Enterprise (WBE), a firm that is at least 51% managed and controlled by a woman, certified by a certifying agency within Illinois.
- \_\_\_\_\_ Evanston Based Enterprise (EBE), a firm located in Evanston for a minimum of one year and which performs a “commercially useful function”.

Total proposed price of response \$ \_\_\_\_\_

Amount to be performed by a M/W/EBE \$ \_\_\_\_\_

Percentage of work to be performed by a M/W/EBE \_\_\_\_\_%

Information on the M/W/EBE Utilized:

Name \_\_\_\_\_

Address \_\_\_\_\_

Phone Number \_\_\_\_\_

Signature of firm attesting to participation \_\_\_\_\_

Title and Date \_\_\_\_\_

Please attach

1. Proper certification documentation if applying as a M/WBE and check the appropriate box below. This M/WBE will be applying with documentation from:

- Cook County                       State Certification
- Federal Certification            Women’s Business Enterprise National Council
- City of Chicago                    Chicago Minority Supplier Development Council

2. Attach business license if applying as an EBE

**Exhibit H**

**M/W/EBE PARTICIPATION WAIVER REQUEST**

I am \_\_\_\_\_ of \_\_\_\_\_, and I have authority to  
(Title) (Name of Firm)  
execute this certification on behalf of the firm. I \_\_\_\_\_ do  
(Name)

hereby certify that this firm seeks to waive all or part of this M/W/EBE participation goal for the following reason(s):

**(CHECK ALL THAT APPLY. SPECIFIC SUPPORTING DOCUMENTATION MUST BE ATTACHED.)**

\_\_\_\_\_ 1. No M/W/EBEs responded to our invitation to bid.

\_\_\_\_\_ 2. An insufficient number of firms responded to our invitation to bid.

**For #1 & 2, please provide a narrative describing the outreach efforts from your firm and proof of contacting at least 15 qualified M/W/EBEs prior to the bid opening. Also, please attach the accompanying form with notes regarding contacting the Assist Agencies.**

\_\_\_\_\_ 3. No subcontracting opportunities exist.

**Please provide a written explanation of why subcontracting is not feasible.**

\_\_\_\_\_ 4. M/W/EBE participation is impracticable.

**Please provide a written explanation of why M/W/EBE participation is impracticable.**

Therefore, we request to waive \_\_\_\_\_ of the 25% utilization goal for a revised goal of \_\_\_\_\_%.

Signature: \_\_\_\_\_  
(Signature)

Date: \_\_\_\_\_

## Exhibit I

### Construction Contractors' Assistance Organizations ("Assist Agencies") Form

AGENCY	DATE CONTACTED	CONTACT PERSON	RESULT OF CONVERSATION
<b>Association of Asian Construction Enterprises (AACE)</b> 5500 Touhy Ave., Unit K Skokie, IL. 60077 Phone: 847/5259693 Perry Nakachii, President			
<b>Black Contractors United (BCU)</b> 400 W. 76th Street Chicago, IL 60620 Phone: 773/483-4000 Fax: 773/483-4150 Email: <a href="mailto:bcunewera@ameritech.net">bcunewera@ameritech.net</a>			
<b>Chicago Minority Business Development Council</b> 105 West Adams Street Chicago, Illinois 60603 Phone: 312-755-8880 Fax: 312-755-8890 Email: <a href="mailto:info@chicagomsdc.org">info@chicagomsdc.org</a> Shelia Hill, President			
<b>Federation of Women Contractors</b> 5650 S. Archer Avenue Chicago, Illinois 60638 Phone: 312/360-1122 Fax: 312/360-0239 Email: <a href="mailto:FWCChicago@aol.com">FWCChicago@aol.com</a> Contact Person: Beth Doria Maureen Jung, President			
<b>Hispanic American Construction Industry (HACIA)</b> 901 W. Jackson, Suite 205 Chicago, IL 60607 Phone: 312/666-5910 Fax: 312/666-5692 Email: <a href="mailto:info@haciaworks.org">info@haciaworks.org</a>			
<b>Women's Business Development Center</b> 8 S. Michigan Ave, Suite 400 Chicago, Illinois 60603 Phone: 312-853-3477 Fax: 312-853-0145 Email: <a href="mailto:wdbc@wdbc.org">wdbc@wdbc.org</a> Carol Dougal, Director			

## EXHIBIT J

### CITY OF EVANSTON LOCAL EMPLOYMENT PROGRAM (LEP) COMPLIANCE

Effective Date January 1, 2015

#### **City of Evanston Ordinance 60-O-14, Local Employment Program (LEP) New Penalties:**

- **Ordinance 60-O-14**, Amendment to the MWEBE/LEP revising the penalty section from a \$100/per day to a 1.0% of total project value penalty can be found at: [Ordinance 60-O-14 Amendment MWEBE LEP](#) of the Evanston City Code Section 1-17-1 (C) can be found at [Municode Library](#). The following are excerpts from Ordinance 60-O-14, Amending City Code Section 1-17-1(C)(11): Penalty.

**If the contactor or subcontractor fails to comply:** The City may impose a fine up to one percent (1.0%) of the approved project price in total. Contractors or subcontractors that are out of compliance due to a resident termination or resignation shall immediately notify the Business Workforce Compliance Coordinator of this occurrence within two (2) business days. Subsequently, the contractor or subcontractor shall have five (5) additional business days to replace a terminated or resigned worker with another resident.

**If the contactor or subcontractor fails to comply:** If the contractor or subcontractor fails to make the replacement or to notify the Business Workforce Compliance Coordinator of this occurrence, the offending party will also be subject to a penalty up to one percent (1.0%) of the approved project price. If the noncompliant contractor makes a good faith effort to replace the resident, the fine may be waived.

**If the contactor or subcontractor fails to comply:** At the sole discretion of the City, a contractor or subcontractor that has violated the terms of the Local Employment Program within a three-year period may be determined a non-responsible bidder and excluded from bidding on future projects for a period of not less than one year.

**If the employee (LEP Evanston resident) fails to comply:** At the sole discretion of the City, an employee that has been hired through the LEP may be removed from the program for a period of not less than one year for failing to adhere to program guidelines or due to termination by the contractor for cause. Such termination process will be reviewed by the Business Workforce Compliance Coordinator.

**\*\*Detailed Local Employment Program Instructions “How to Comply” can be found at: [Local Employment Program Detailed Instructions](#)**

**Local Employment Program or Exhibit F Questions:** City staff is available for assistance to help with compliance. Submit questions in writing to Sharon A. Johnson, Business Workforce Compliance Coordinator at [shjohnson@cityofevanston.org](mailto:shjohnson@cityofevanston.org).

**EXHIBIT J**

**LOCAL EMPLOYMENT PROGRAM COMPLIANCE**  
**CITY CODE SECTION 1-17-1(C): LOCAL EMPLOYMENT PROGRAM**

I have read and understood the requirements of the City of Evanston Local Employment Program (“LEP”) as set forth in City of Evanston Code Section 1-17-1(C): Local Employment Program. I intend to comply with the program as follows:

Estimated total labor cost = \_\_\_\_\_ 15% of total labor cost = \_\_\_\_\_

- \_\_\_\_\_ My total bid, including all alternates, is under \$250,000, and the LEP does not apply.
- \_\_\_\_\_ My total bid, including all alternates, is equal to or greater than \$250,000, and I already employ, and will continue to employ for the duration of the contract for which I am submitting this bid, Evanston residents (residing in zip codes 60201 or 60202) for at least 15% of all hours worked at the construction site by construction trade workers.
- \_\_\_\_\_ My total bid, including all alternates, is equal to or greater than \$250,000, and I will employ, for the duration of the contract for which I am submitting this bid, through use of the City of Evanston database or otherwise, Evanston residents (residing in zip codes 60201 or 60202) for at least 15% of all hours worked at the construction site by construction trade workers.
- \_\_\_\_\_ My total bid, including all alternates, is equal to or greater than \$250,000, and I have been unable to comply with the LEP requirements but am willing to work with the City to achieve compliance.
- \_\_\_\_\_ My total bid, including all alternates, is equal to or greater than \$250,000, and after having made sincere attempt to comply as noted below, I seek a waiver on a portion or all of the LEP requirements on this contract. Complete next section “Reasons for Waiver Request” below.

**I UNDERSTAND THAT FAILURE TO COMPLY WITH THE LEP, REGARDLESS OF INTENT, MAY RESULT IN MAXIMUM PENALTY AS SET FORTH IN CITY CODE SECTION 1-17-1(C)(11), AS AMENDED.**

**WAIVER WILL BE GRANTED ONLY AFTER SINCERE ATTEMPT TO COMPLY\***

REASONS FOR WAIVER REQUEST: PLEASE CHECK ALL THAT APPLY AND COMPLETE INFORMATION REQUESTED:

- 1. I have made sincere attempt as otherwise indicated below, but have nonetheless been unable to comply.
  - a. I do or will employ Evanston residents for the project, but such employment amounts to \_\_\_\_% of total labor cost.
- 2. The nature of the job is so technical that after having made sincere attempt as otherwise indicated below, I have been unable to locate any Evanston residents qualified to perform any aspects of the work. Please describe applicable job requirements/qualifications. Attach separate sheet if necessary:

\_\_\_\_\_

\*THE FOLLOWING DEMONSTRATE **SINCERE ATTEMPT TO COMPLY**: PLEASE CHECK EACH BOX COMPLETED, AS APPLICABLE:

- 3. I have utilized the local resident database and otherwise worked with the City in attempt to hire Evanston residents in compliance with LEP on this project, and have nonetheless been unable to comply;
- 4. I have placed one or more ads in a local newspaper seeking to hire Evanston residents in compliance with LEP on this project, and have nonetheless been unable to comply; and
- 5. If I am utilizing union labor, I have contacted Chicagoland labor unions to request Evanston residents for employment in compliance with LEP on this project, and have nonetheless been unable to comply.

I have read The City of Evanston, Local Employment Program (LEP) requirements as set forth in City Code Section 1-17-1(C): Local Employment Program. I understand and will comply with the LEP requirements for this project with respect to the job and/or any waiver, as applicable. **I UNDERSTAND THAT IF MY APPLICATION IS NOT COMPLETE, MY BID MUST BE REJECTED.**

SIGNED:

\_\_\_\_\_  
Signature Printed Name and Title Date

On behalf of Company: \_\_\_\_\_



**EXHIBIT K**

**CERTIFICATE OF COMPLIANCE  
WITH PREVAILING WAGE RATE ACT**

The undersigned, upon being first duly sworn, hereby certifies to the City of Evanston, Cook, County, Illinois, that all work under this contract shall comply with the Prevailing Wage Rate Act of the State of Illinois, 820 ILCS 130 *et seq*, and as amended by Public Acts 86-799 and 86-693 and current City of Evanston Resolution, with rates to be paid in effect at time work is performed. Contractors shall submit monthly certified payroll records to the city.

Name of Contractor: \_\_\_\_\_

By: \_\_\_\_\_

By: State of \_\_\_\_\_, County of \_\_\_\_\_

Subscribed and sworn to before me this \_\_\_\_\_ day

of \_\_\_\_\_, \_\_\_\_\_.

Notary Public

**Exhibit L**

**FIRM EXPERIENCE TABLE**

<b>Firm Experience Within Past 10 Years</b> List 3 most current and similar projects, including Project Name, Client Organization, Reference Name, Title, Phone Number, and Email Address			
<b>Work Type</b>	<b>Client 1</b>	<b>Client 2</b>	<b>Client 3</b>
Ice Rink Construction			
Recreation Center Construction			
Library Construction			
Athletic Field Construction			

**Note 1:** Proposers may re-create this table to better accommodate their information, so long as all required information is provided and table follows the general format shown above.

**Note 2:** Provide firm experience references for the prime consultant and sub-consultants.

**Exhibit M**

**PROJECT TEAM EXPERIENCE TABLE**

<p align="center"><b>Team Experience Within Past 10 Years</b>                      List most current similar projects, including Project Name, Client Organization,                      Reference Name, Title, Phone Number, and Email Address</p>									
Client / Location (Year) <sup>1</sup>	Project Type	Included ice rink? (yes/no)	Included recreation center? (yes/no)	Included library? (yes/no)	Included athletic fields? (yes/no)	Project Manager <sup>2</sup>	Key Team Member #1 <sup>2</sup>	Key Team Member #2 <sup>2</sup>	Reference Contact Information <sup>3</sup>

<sup>1</sup> Include, at a minimum, the last three similar projects for each team member.

<sup>2</sup> Indicate actual team member names. Provide a column for each key team member on this proposal.

<sup>3</sup> Provide name, title, email address and phone number for each reference.

**Exhibit N**

**REFERENCE PROJECT INFORMATION FORM  
(Complete one form for each project)**

Project Name: \_\_\_\_\_

Description of project scope: \_\_\_\_\_  
\_\_\_\_\_

Description of work performed: \_\_\_\_\_  
\_\_\_\_\_

Self-performed trades: \_\_\_\_\_  
\_\_\_\_\_

Contract type: \_\_\_\_\_

Construction manager: \_\_\_\_\_

Awarded contract amount: \_\_\_\_\_

Final contract amount: \_\_\_\_\_

Change Order Costs in dollars and as  
a percentage of awarded contract: \_\_\_\_\_

Project Start Date: \_\_\_\_\_

Project Completion Date: \_\_\_\_\_

Owner Contact: \_\_\_\_\_

Address: \_\_\_\_\_

Phone: \_\_\_\_\_

Email: \_\_\_\_\_

Architect/Engineer Contact: \_\_\_\_\_

Address: \_\_\_\_\_

Phone: \_\_\_\_\_

Email: \_\_\_\_\_

**Exhibit O**  
**PROPOSAL COST TABLE**

Task	Sub-task	Cost
<b>Task 1 – Pre-Construction (Not-to-Exceed)</b>		
	Design and Constructability Evaluation	\$
	Cost Estimating	\$
	Permit Preparation	\$
	Bid Preparation	\$
	Other Services	\$
	Reimbursable Items	\$
Task 1 Subtotal		\$
<b>Task 2 – Construction (Estimated)</b>		
	Construction Manager Fees	\$
	General Requirements	\$
	Existing Conditions	\$
	Concrete	\$
	Masonry	\$
	Metals	\$
	Wood, Plastics and Composites	\$
	Thermal and Moisture Protection	\$
	Openings	\$
	Finishes (interior)	\$
	Specialties	\$
	Equipment	\$
	Furnishings	\$
	Special Construction	\$
	Conveying Equipment	\$
	Fire Suppression	\$
	Plumbing	\$
	Heating, Ventilation and Air Conditioning	\$
	Integrated Automation	\$
	Electrical	\$
	Communications	\$
	Electronic Safety and Security	\$
	Earthwork	\$
	Exterior Improvements	\$
	Utilities	\$
Task 2 Subtotal		\$
Grand Total		\$

**Exhibit P**  
**AIA DOCUMENT ACKNOWLEDGEMENT**

The City intends to utilize AIA Document A133-2009 and AIA Document A201-2007 with modifications noted in the following pages as the agreement for this project. Identify all exceptions to the agreement that would prevent your firm from executing it. **The City shall not consider or negotiate regarding exceptions submitted at any time after the submission of the Proposer's response.** *Please check one of the following statements:*

\_\_\_\_I have read the agreement and plan on executing the agreement without any exceptions.

\_\_\_\_My firm cannot execute the agreement unless the exceptions noted below or in the attached sample professional services agreement are made.

**\*\*\*Please be aware that submitting exceptions to the contract may impact the likelihood of your firm being selected to perform this work.**

List exceptions in the area below:

---

---

---

---

---

---

---

---

---

---

**Authorized  
Signature:**

\_\_\_\_\_

**Company  
Name:**

\_\_\_\_\_

**Exhibit P**  
**City of Evanston Modifications to AIA Documents A133-2009 and AIA A201-2007**

**Supplemental Contract Provisions: Any conflicts between Exhibit P and AIA Documents A133-2009 and AIA 201-2007, this Exhibit shall prevail and be the binding document between the parties. If Exhibit P is silent on the issue, the AIA documents shall prevail.**

**Supplemental Contract Provisions:**

1. GOVERNING LAW

- A. This contract shall be governed by and construed according to the laws of the State of Illinois. In the event of any disputes or litigation, the venue will be Cook County, Illinois.

2. PAYMENTS

- A. Progress payments will be made less a 10% retainage for each payment, which will be held until final acceptance of the work by the City. Certification of each Application for Payment will be made by the City's representative.
- B. All payments will be made in accordance with *Illinois Local Government Prompt Payment Act*.
- C. Final payment shall not be made until punch list work is complete and all final lien waivers, certified payroll, warranties, and other close out documents are received.

3. EQUAL EMPLOYMENT OPPORTUNITY

- A. In the event of the contractor's noncompliance with any provision of the Illinois Human Rights Act or Section 1-12-5 of the Evanston City Code, the contractor may be declared non-responsible and therefore ineligible for future contracts or subcontracts with the City of Evanston, and the contract may be canceled or voided in whole or in part, and such other sanctions or penalties may be imposed or remedies invoked as provided by Statute or regulation.
- B. During the performance of this contract, the contractor agrees as follows:
  - a. That it will not discriminate against any employee or applicant for employment because of race, color, religion, sex, national origin or ancestry, or age or physical or mental handicap that does not impair ability to work, and further that it will examine all job classifications to determine if minority persons or women are underutilized and will take appropriate affirmative action to rectify any such under-utilization. Contractor shall comply with all requirements of City of Evanston Code Section 1-12-5.
  - b. That, in all solicitations or advertisements for employees placed by it or on its behalf, it will state that all applicants will be afforded equal opportunity without discrimination because of race, color, religion, sex, national origin or ancestry.
  - c. That, if it hires additional employees in order to perform this contract, or any portion hereof, it will determine that availability (in accordance with the Fair Employment Commission's Rules and Regulations for Public Contracts) of minorities and women in the area(s) from which it may reasonably recruit and it will hire for each job classification for which

employees are hired in such a way that minorities and women are not underutilized.

- d. That it will send to each labor organization or representative of workers with which it has or is bound by a collective bargaining or other agreement or understanding, a notice advising such labor organization or representative of the contractor's obligations under the Illinois Fair Employment Practices Act and the Fair Employment Practices Commission's Rules and Regulations for Public Contracts. If any such labor organization or representative fails or refuses to cooperate with the contractor in its efforts to comply with such Act and Rules and Regulations, the contractor will promptly so notify the Illinois Fair Employment Practices Commission and the contracting agency and will recruit employees from other sources when necessary to fulfill its obligations hereunder.
- e. That it will submit reports as required by the Illinois Fair Employment Practices Commission's Rules and Regulations for Public Contracts, furnish all relevant information as may from time to time be requested by the Fair Employment Practices Commission or the contracting agency, and in all respects comply with the Illinois Fair Employment Practices Commission's Rules and regulations for Public Contracts.
- f. That it will permit access to all relevant books, records, accounts and work sites by personnel of the contracting agency, the City Manager, the Commission and the Illinois Fair Employment Practices Commission for purposes of investigation to ascertain compliance with the Illinois Fair Employment Practices Act and the Fair Employment Practices Act and the Fair Employment Practices Commission's Rules and Regulations for Public Contract.
- g. That it will include verbatim or by reference the provisions of subsections (A) through (G) of this clause in every performance subcontract as defined in Section 2.10(b) of the Fair Employment Practices Commission's Rules and Regulations for Public Contracts so that such provisions will be binding upon every such subcontractor; and that it will also include the provisions of subsections (A), (E), (F), and (G) in every supply subcontract as defined in Section 2.10(a) of the Fair Employment Practices Commission's Rules and Regulations for Public Contracts so that such provisions will be binding upon every such subcontractor. In the same manner as with other provisions of this contract, the contractor will be liable for compliance with applicable provisions of this clause by all its subcontractors; and further it will promptly notify the contracting agency and the Illinois Fair Employment Practices Commission in the event any subcontractor fails or refuses to comply therewith. In addition, no contractor will utilize any subcontractor declared by the Fair Employment Practices Commission to be non-responsible and therefore ineligible for contracts or subcontracts with the State of Illinois or any of its political subdivisions or municipal corporations.

#### 4. M/W/EBE GOAL

The City of Evanston has a goal of awarding 25% of its contracts to Minority-Owned, Women-Owned, and Evanston-based businesses (M/W/EBEs). All Bidders must



state the proposed involvement of M/W/EBEs in completing a portion of the services required by the City by completing the attached M/W/EBE forms. Any questions regarding M/W/EBE compliance should be submitted in writing to Sharon A. Johnson, Business Workforce Compliance Coordinator at [shjohnson@cityofevanston.org](mailto:shjohnson@cityofevanston.org) or Tammi Nunez Purchasing Manager at [tnunez@cityofevanston.org](mailto:tnunez@cityofevanston.org).

5. LOCAL EMPLOYMENT PROGRAM REQUIREMENTS

In an effort to increase hiring of economically disadvantaged Evanston residents on certain City construction projects, the contractor shall comply with the provisions of the City of Evanston's Local Employment Program Ordinance (LEP) set forth in Section 1-17-1 (C) of the Evanston City Code. The intent of the LEP is to have Evanston residents employed at the construction site as laborers, apprentices and journeymen in such trades as electrical, HVAC, carpenters, masonry, concrete finishers, truck drivers and other construction occupations necessary for the project. Any questions regarding LEP compliance should be submitted in writing to Sharon A. Johnson, Business Workforce Compliance Coordinator at [shjohnson@cityofevanston.org](mailto:shjohnson@cityofevanston.org) or Tammi Nunez Purchasing Manager at [tnunez@cityofevanston.org](mailto:tnunez@cityofevanston.org).

**NOTE: CITY OF EVANSTON ORDINANCE 60-O-14 AMENDMENT LOCAL EMPLOYMENT PROGRAM (LEP) available on the City website at: [Ordinance 60-O-14 Amendment LEP](#)**

6. AFFIRMATIVE ACTION IN SUB-CONTRACTING (EXCERPT FROM RESOLUTION 59-R-73)

"Contractor agrees that he shall actively solicit bids for the subcontracting of goods or services from qualified minority businesses. At the request of the City, Contractor shall furnish evidence of his compliance with this requirement of minority solicitation. Contractor further agrees to consider the grant of subcontracts to said minority bidders on the basis of substantially equal bids in the light most favorable to said minority businesses. Contractor further affirms that in obtaining his performance and bid bonds, he will seek out and use companies who have records of, and/or who will make commitments to, the bonding of minority contractors on a rate basis comparable to their bonding of similar non-minority contractors. The contractor may be required to submit this evidence as part of the bid or subsequent to it."

7. PREFERENCE TO CITIZENS

The Contractor shall abide by the Illinois Preference Act, 30 ILCS 570 et seq., which stipulates that whenever there is a period of excessive unemployment in Illinois, defined as any month immediately following two (2) consecutive months during which the level of unemployment in Illinois exceeds five percent (5%) as measured by the U.S. Bureau of Labor Statistics in its monthly publication of employment and unemployment figures, the Contractor shall employ only Illinois laborers unless otherwise exempted as so stated in the Act. ("Illinois laborer" means any person who has resided in Illinois for at least 30 days and intends to become or remain an Illinois resident) Other laborers may be used IF Illinois laborers are not available or are incapable of performing the particular type of work involved if so certified by the Contractor and approved by the project engineer.

8. RESTORATION OF SITE

A. Prior to final payment, contractor shall fully restore all property disturbed or damaged during the course of this work. This includes, but is not limited to public property, (walks, curbs, roadways, trees, etc.) private property, and

utilities. This shall also include removal of temporary facilities erected during the course of this contract and restoration of these areas.

- B. All restoration work shall be subject to the approval of the City and shall restore the property to a condition at least equal to that existing prior to the start of this contract.
- C. All restoration work of property damaged by contractor shall be accomplished at the sole expense of the contractor.

#### 9. PREVAILING WAGE

- A. Prospective Bidders shall thoroughly familiarize themselves with the provisions of the above-mentioned Act and shall prepare any and all bids/bids in strict compliance therewith.
- B. All contractors and subcontractors on public works projects ***must submit certified payrolls*** on a monthly basis to the City's project manager and business work force development coordinator, along with a statement affirming that such records are true and accurate, that the wages paid to each worker are not less than the required prevailing rate and that the contractor is aware that filing records her or she knows to be false is a Class B misdemeanor.
- C. The certified payroll record must include for every worker employed on the public works project the name, address, telephone number, social security number, job classification, hourly wages paid in each pay period, number of hours worked each day, and starting and ending time of work each day. These certified payroll records are considered public records and public bodies must make these records available to the public under the Freedom of Information Act, with the exception of the employee's address, telephone number and social security number. Any contractor who fails to submit a certified payroll or knowingly files a false certified payroll is guilty of a Class B misdemeanor.
- D. All certified payrolls shall be submitted in electronic format, preferably a PDF file.
- E. As a condition of receiving payment, Contractor must (i) be in compliance with the Agreement, (ii) pay its employees prevailing wages when required by law (Examples of prevailing wage categories include public works, printing, janitorial, window washing, building and grounds services, site technician services, natural resource services, security guard and food services). Contractor is responsible for contacting the Illinois Dept. of Labor 217-782-6206; <http://www.illinois.gov/idol/Laws-Rules/CONMED/Pages/Rates.aspx> to ensure compliance with prevailing wage requirements), (iii) pay its suppliers and subcontractors according to the terms of their respective contracts, and (iv) provide lien waivers to the City upon request.

#### 10. CONTRACTOR REQUIREMENTS

- A. The Contractor shall abide by and comply with all local, State and federal laws and regulations relating to contracts involving public funds and the development/construction of public works, buildings, or facilities. The scale of wages to be paid shall be obtained from Illinois Department of Labor and posted by the Contractor in a prominent and accessible place at the project work site.
- B. The Contractor certifies it has not been barred from being awarded a contract with a unit of State or local government as a result of bid rigging or bid rotating or any similar offense (720 ILCS 5/33 E-3, E-4).
- C. The Contractor certifies, pursuant to the Illinois Human Rights Act (775 ILCS 5/2-105), that it has a written sexual harassment policy that includes, at a minimum,

the following information: (1) the illegality of sexual harassment, (2) the definition of sexual harassment under State law, (3) a description of sexual harassment utilizing examples, (4) the Contractor's internal complaint process including penalties, (5) legal recourse, investigation and complaint process available through the Illinois Department of Human Rights and the Human Rights Commission and directions on how to contact both; and (6) protection against retaliation as provided by Section 6-101 of the Illinois Human Rights Act.

- D. The Contractor shall abide by the "Illinois Preference Act" which stipulates that whenever there is a period of excessive unemployment in Illinois, defined as any month immediately following two (2) consecutive months during which the level of unemployment in Illinois exceeds five percent (5%) as measured by the U.S. Bureau of Labor Statistics in its monthly publication of employment and unemployment figures, the Contractor shall employ only Illinois laborers unless otherwise exempted as so stated in the Act. ("Illinois laborer" means any person who has resided in Illinois for at least 30 days and intends to become or remain an Illinois resident) Other laborers may be used IF Illinois laborers are not available or are incapable of performing the particular type of work involved if so certified by the Contractor and approved by the project engineer.

#### 11. BOND – PERFORMANCE, MATERIAL, & LABOR

- A. The Construction Manager shall, within ten (10) calendar days after acceptance of the bid by the City, furnish a performance bond for 110% of the full amount of the contract from insurance companies having not less than A+ Policyholders Rating from the most recent Alfred M. Best and Co., Inc. listing available. Certification of the insurance company's rating shall be provided prior to contract implementation and quarterly thereafter until contract completion. Should such rating fall below the required A+ level during performance of the contract, it will be the contractor's responsibility to notify the City and provide a new bond from an insurance company whose rating meets the City's requirements.
- B. If the contractor has more than one project for which there is a contract with the City of Evanston the contractor shall provide a separate Performance Bond for each project.

#### 12. LIQUIDATED DAMAGES

- A. The Contractor must commence work within 10 days of notice from the City and the work must be substantially completed by TBD. In the event the work is not substantially completed by TBD, then in addition to any remedies available to the City, the Contractor will pay to the City the sum of \$1,000 per day for each calendar day beyond those dates, until substantial completion of the work has been achieved. This payment is for liquidated damages, in addition to any other damages that may be incurred by the City, and not as a penalty. All such liquidated damages may be set-off against any moneys that may be due the contractor.
- B. Substantial Completion shall be defined as the stage in the progress of the work when the work or designated portion thereof is sufficiently complete in accordance with the Contract Documents so that the City can occupy or utilize the work for its intended use. Substantial Completion will be certified by the issuance of a Certificate of Substantial Completion, to be issued by the City's representative, when the Contractor has satisfied the above statement and

billed the City for a minimum of 90% of the total value of the work.

### 13. WARRANTY

- A. The contractor warrants that all goods and services furnished to the City shall be in accordance with specifications and free from any defects of workmanship and materials: that goods furnished to the City shall be merchantable and fit for the City's described purposes, and that no governmental law, regulation, order, or rule has been violated in the manufacture or sale of such goods.
- B. The contractor warrants all equipment furnished to be in acceptable condition, and to operate satisfactorily for a period of one (1) year from delivery of, or the completion of installation, whichever is latest, unless stated otherwise in the specifications, and that if a defect in workmanship and/or quality of materials are evidenced in this period, the Seller shall remit full credit, replace, or repair at City's discretion immediately, such equipment and/or parts that are defective at no additional cost to the City.
- C. The contractor warrants to the City that each item furnished hereunder, and any component part thereof, will be new and in conformity with the specifications in all respects, unless otherwise specified, and is of the best quality of its respective kind, free from faulty workmanship, materials, or design, and installed sufficiently to fulfill any operating conditions specified by the City.
- D. The contractor shall repair or replace any item or component part thereof found not to be in conformity with this paragraph provided the City notified the Seller of such nonconformity within one (1) year after initial use or within eighteen (18) months after delivery, whichever occurs first. In the event Seller fails to proceed diligently to so replace or repair within a reasonable time after receipt of such notice, the City may undertake or complete such replacement or repair for Seller's account, and the seller will be responsible for any additional costs. Acceptance shall not relieve the seller of its responsibility.

### 14. TAXES

- A. Federal Excise Tax does not apply to materials purchased by the City of Evanston by virtue of Exemption Certificate No. A-208762, Illinois Retailers' Occupation Tax, Use Tax, and Municipal Retailers' Occupation Tax do not apply to materials or services purchased by the City of Evanston by virtue of Statute.
- B. The City of Evanston is exempt from Illinois Sales Tax by virtue of Exemption Identification number E9998-1750-07.
- C. The City's federal tax ID number is 36-6005870.

### 15. PERMITS & FEES

The Construction Manager must secure and pay for any licenses required by the City of Evanston. Necessary building permits will be required, but all permit fees will be waived and moneys for same must not be included in any bid. Permits required by any other governmental agency will not be waived.

### 16. LIENS

Neither the final payment nor any part of any retained percentages, shall become due until the contractor, delivers to the City, a complete release of all liens arising out of this contract, or receipts in full in lieu thereof and, if required in either case, an affidavit that so far as it has knowledge or information the releases and receipts include all the labor and material for which a lien could be filed. If any lien remains unsatisfied after all payments are made the contractor shall refund to the City all moneys that the latter may

be compelled to pay in discharging such a lien, including all costs and attorney's fees. Construction manager shall also submit trailing lien waivers as a condition of approval of each pay application.

**Modifications to AIA Contract Document A133-2009:**

- 2.2.9 This section shall be modified or stricken as the City of Evanston is tax exempt. Additionally, Construction Manager must submit the City's sales tax exemption information at the time of purchase to receive the sales tax exemption on transactions.
- 4.2.2 This section shall be modified to indicate that payment will be made in accordance with the Illinois Prompt Payment Act.
- 6.6.2 This section shall be modified or stricken as the City of Evanston is tax exempt. Additionally, section shall include statement that Construction Manager will submit sales tax exemption information prior to purchases to prevent sales tax from being assessed.
- 6.6.3 This section shall be modified as City of Evanston building permit fees will be waived.
- 7.1.3 This section shall be modified to indicate that payment will be made in accordance with the Illinois Prompt Payment Act.
- 7.1.7 This section shall be modified to indicate that the City will withhold 10% retainage on all progress payments.
- 7.2.1 This section shall be modified to indicate that payment will be made in accordance with the Illinois Prompt Payment Act.

**Modifications to AIA Contract Document A201-2007:**

- 1.1.1 Item (4) a written order for a minor change in the Work issued by the Architect shall be stricken.
- 1.5.1 This section shall be modified to indicate that the City is the owner of the instruments of service.
- 1.1.8 This section shall be stricken.
- 3.5 This section shall be modified to include the supplemental contract provisions above.
- 3.6 This section shall be modified or stricken as the City of Evanston is tax exempt. Additionally, section shall include statement that Construction Manager will submit sales tax exemption information prior to purchases to prevent sales tax from being assessed.

- 3.7 This section shall be modified as City of Evanston building permit fees will be waived. Permit fees assessed by another governmental agency must be secured and paid for by the Construction Manager.
- 11.3.7 This section shall be stricken.
- 11.3.8 This section shall be stricken.
- 11.3.9 This section shall be stricken.
- 11.3.10 This section shall be stricken.
- 11.4 This section shall be modified to include performance bond requirements at 110% of contract value and insurance limits as described in section 3 of the RFP.
- 13.1 This section shall be modified to indicate that the Contract shall be governed by the laws of the State of Illinois and the venue must be Cook County, Illinois.
- 13.6 This section shall be modified to indicate that payment will be made in accordance with the Illinois Prompt Payment Act.
- 15.1.2 This section shall be modified to eliminate all reference to the Initial Decision Maker and Architect.
- 15.1.3 This following sentence shall be deleted from this section: "The Architect will prepare Change Orders and issue Certificates for Payment in accordance with the decisions of the Initial Decision Maker."
- 15.1.6 This section shall be stricken.
- 15.2.1 This section shall be stricken.
- 15.2.2 This section shall be stricken.
- 15.2.3 This section shall be stricken.
- 15.2.4 This section shall be stricken.
- 15.2.5 This section shall be stricken.
- 15.2.6 This section shall be stricken.
- 15.2.6.1 This section shall be stricken.
- 15.3 This section shall be stricken.
- 15.4 This section shall be stricken.

**EXHIBIT Q**

**PROPOSAL SUBMITTAL LABEL**

**CUT AND ATTACH LABEL ON OUTSIDE OF SEALED BID/PROPOSAL SUBMITTAL**



-----  
**ADDRESS SUBMITTALS:**      **CITY OF EVANSTON - PURCHASING OFFICE, ROOM 4200  
LORRAINE H. MORTON CIVIC CENTER  
2100 RIDGE AVENUE - EVANSTON, ILLINOIS 60201**

**SUBMITTAL NUMBER:** \_\_\_\_\_

**SUBMITTAL NAME:** \_\_\_\_\_

**SUBMITTAL DUE DATE/TIME:** \_\_\_\_\_

**COMPANY NAME:** \_\_\_\_\_

**COMPANY ADDRESS:** \_\_\_\_\_

**COMPANY TELEPHONE #:** \_\_\_\_\_

-----

# ISSUED FOR 100% SCHEMATIC DESIGN

Client Submission - September 11, 2017

## ROBERT CROWN COMMUNITY CENTER ICE COMPLEX AND LIBRARY

Woodhouse Tinucci Architects  
MacLennan Jaunkalns Miller Architects





## CONTENTS

01. Title Page	
Table of Contents	
02. Team Names	03
03. Renderings	
Site Plan	04
Landscape Plan	05
Floor Plan Diagrams	05
Exterior Views	06
Interior Views	08
04. Programming / Research	
Project Program	10
Room Data Sheets	13
LEED Checklist	61
Code/Occupancy/Zoning Analysis	78
Traffic Report and Key Recommendations	80
05. Outline Specification	55
Finishes Specification	85
06. Schematic Scope Narratives	55
Civil/Site	85
Landscape	85
Structural	85
MEP/FP	85
AV	85
Sportsfields	85
Sport Lighting	85
07. Drawing Set	55
Site/Landscape Plan	85
Grading Plan	99
Structural Framing Plan	99
Floor Plans	99
Exterior Elevations	99
Building Sections	99

## PROJECT TEAM

### ARCHITECTURE:

Woodhouse Tinucci Architects  
230 W. Superior St. Fl 6  
Chicago, Illinois 60654

MacLennan Jaunkalns Miller Architects  
425 Adelaide Street West, Level 6  
Toronto, Ontario M5V 3C1

### CIVIL:

Terra Engineering, Ltd  
225 West Ohio Street  
Chicago, Illinois 60654

### LANDSCAPE:

Conservation Design Forum  
403 West St. Charles Road  
Lombard, Illinois 60148

### STRUCTURAL:

Steam-Joglekar Ltd.  
223 West Jackson Boulevard #1110  
Chicago, Illinois 60606

### MEP/FP:

Smith + Andersen  
500-4211 Yonge Street  
Toronto, Ontario M2P 2A9

### SPORTSFIELD:

Jeffrey L. Bruce & Company  
1907 Swift Street, Suite 204  
North Kansas City, Missouri 64116

### SPORTS LIGHTING:

Musco Lighting  
100 1st Avenue West, P.O. Box 808  
Oskaloosa, Iowa 52577

### GEOTECHNICAL:

Soils & Materials  
8 West College Drive, Suite C  
Arlington Heights, Illinois 60004

### TRAFFIC:

KLOA  
9575 West Higgins Road, Suite 400  
Rosemont, Illinois 60018

**SITE PLAN**

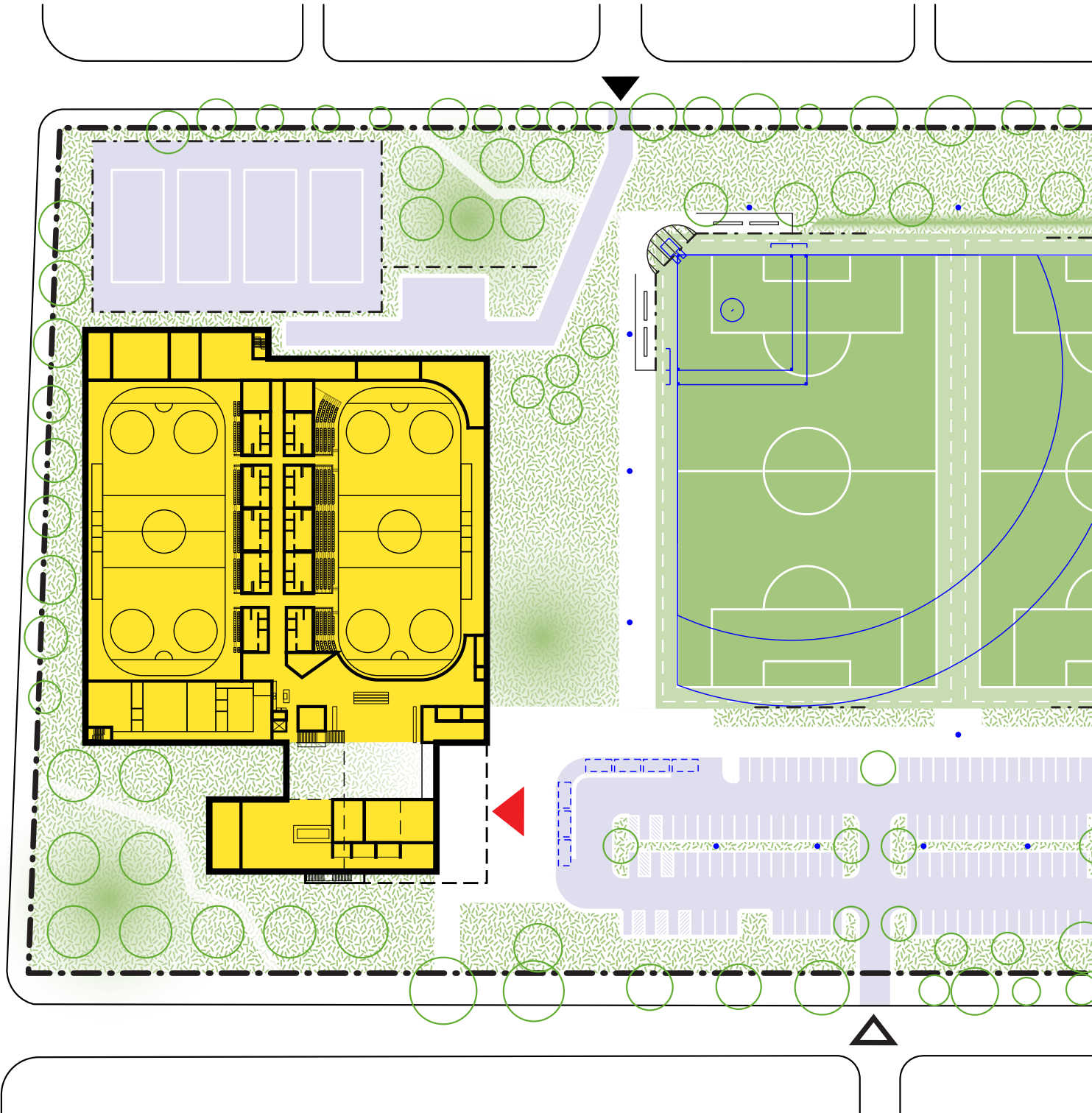

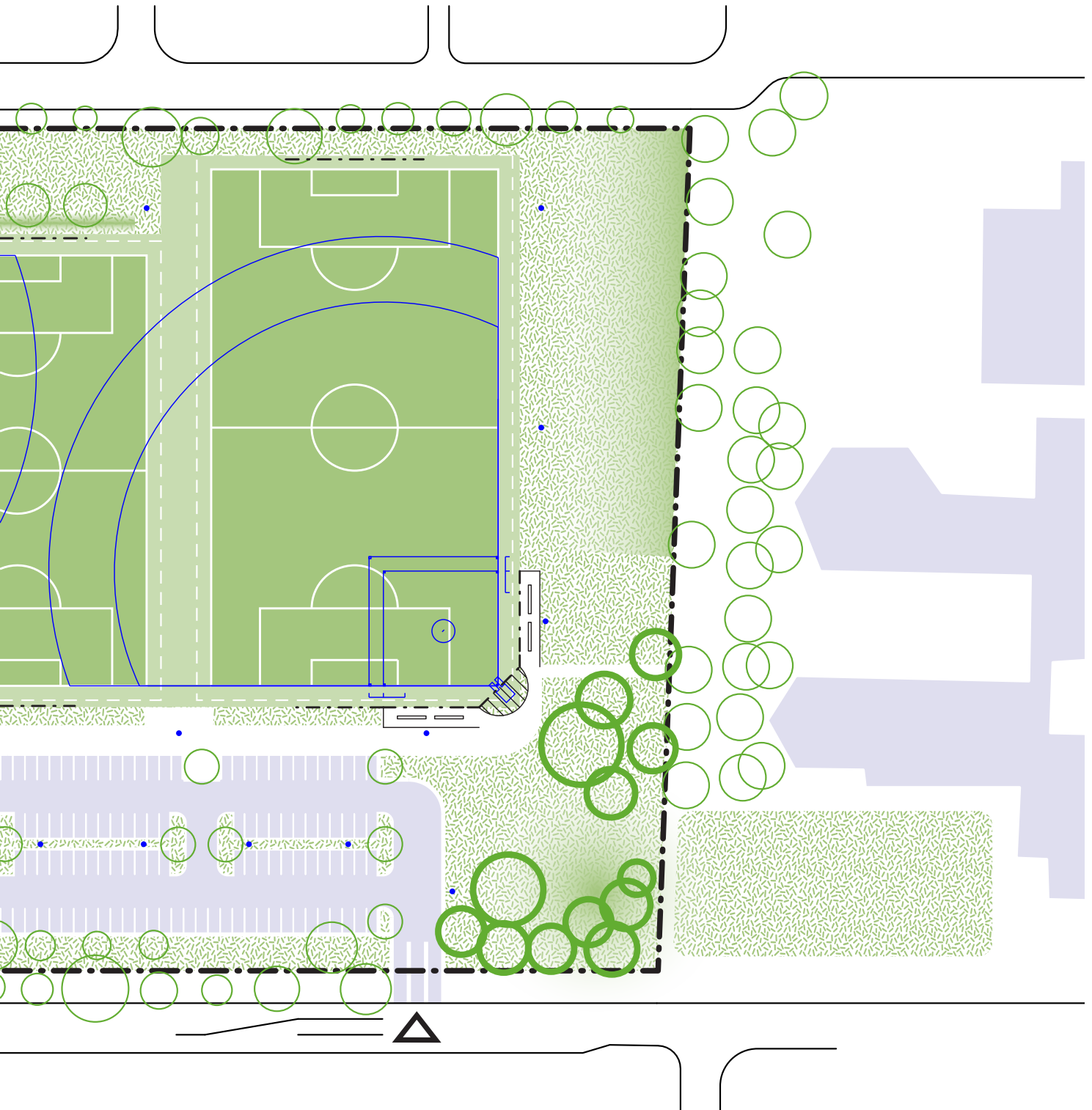

**LANDSCAPE PLAN**

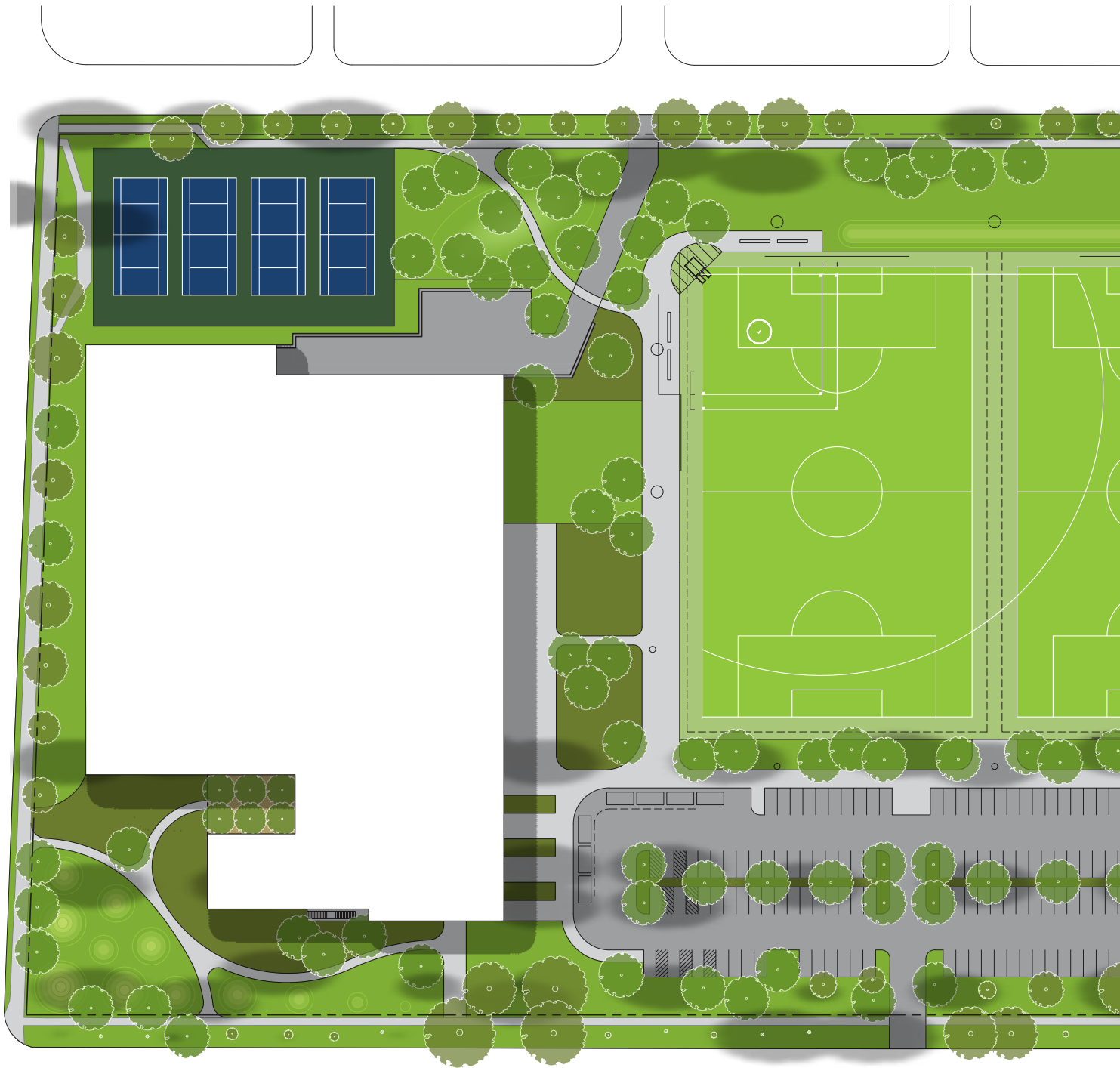



**PLAN DIAGRAM - FIRST FLOOR**

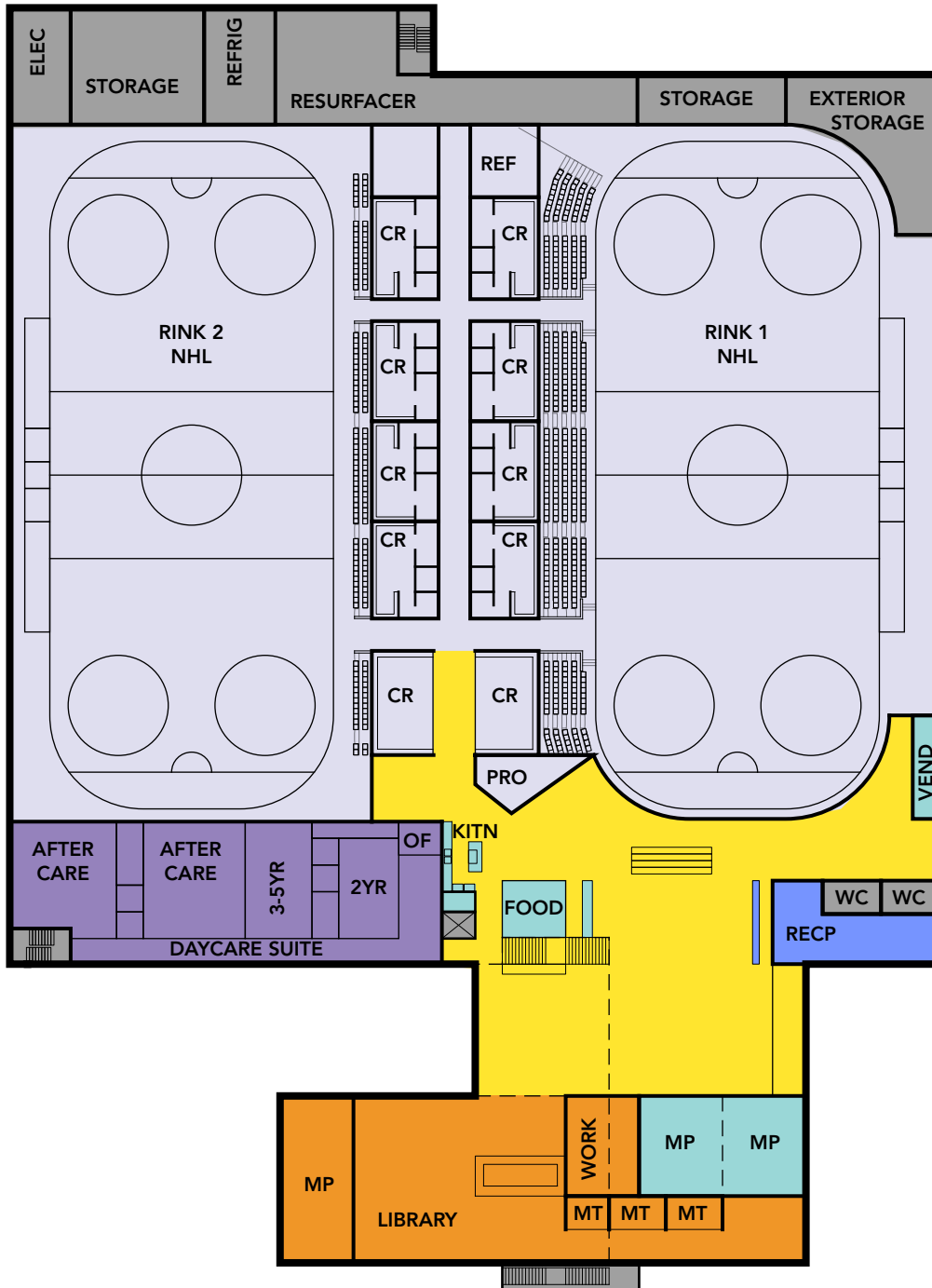

PLAN DIAGRAM - SECOND FLOOR

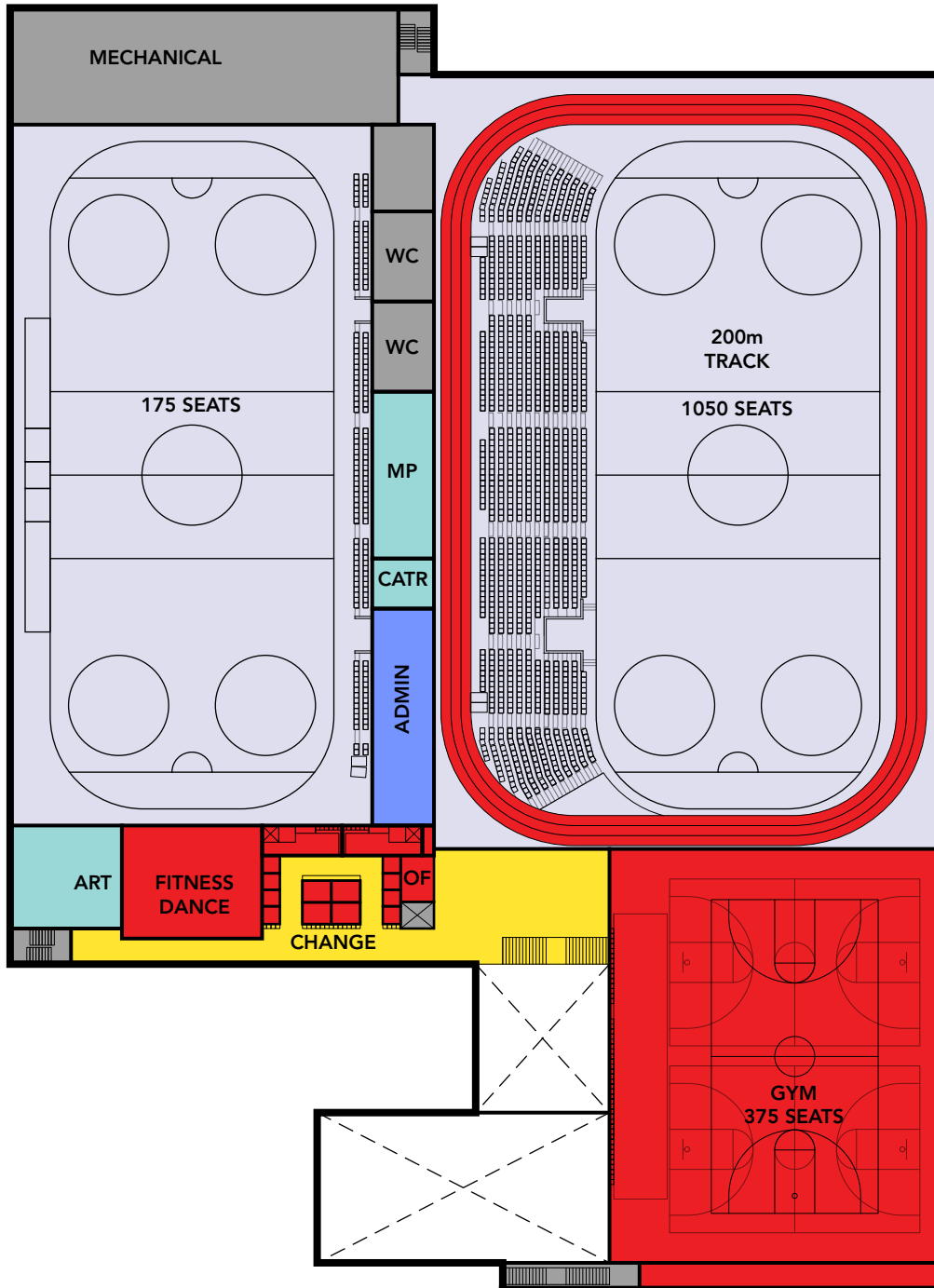



**EXTERIOR VIEWS**



EXTERIOR VIEWS

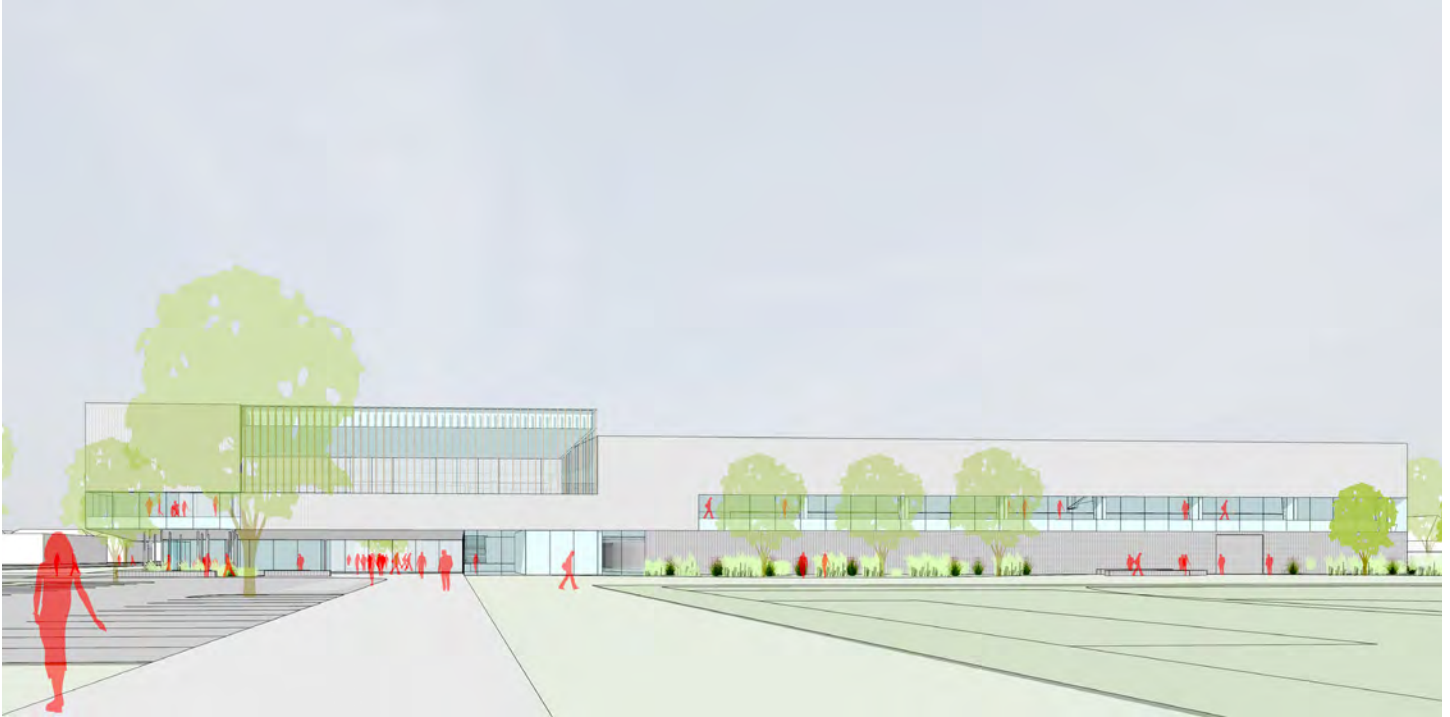

**INTERIOR VIEWS**



INTERIOR VIEWS

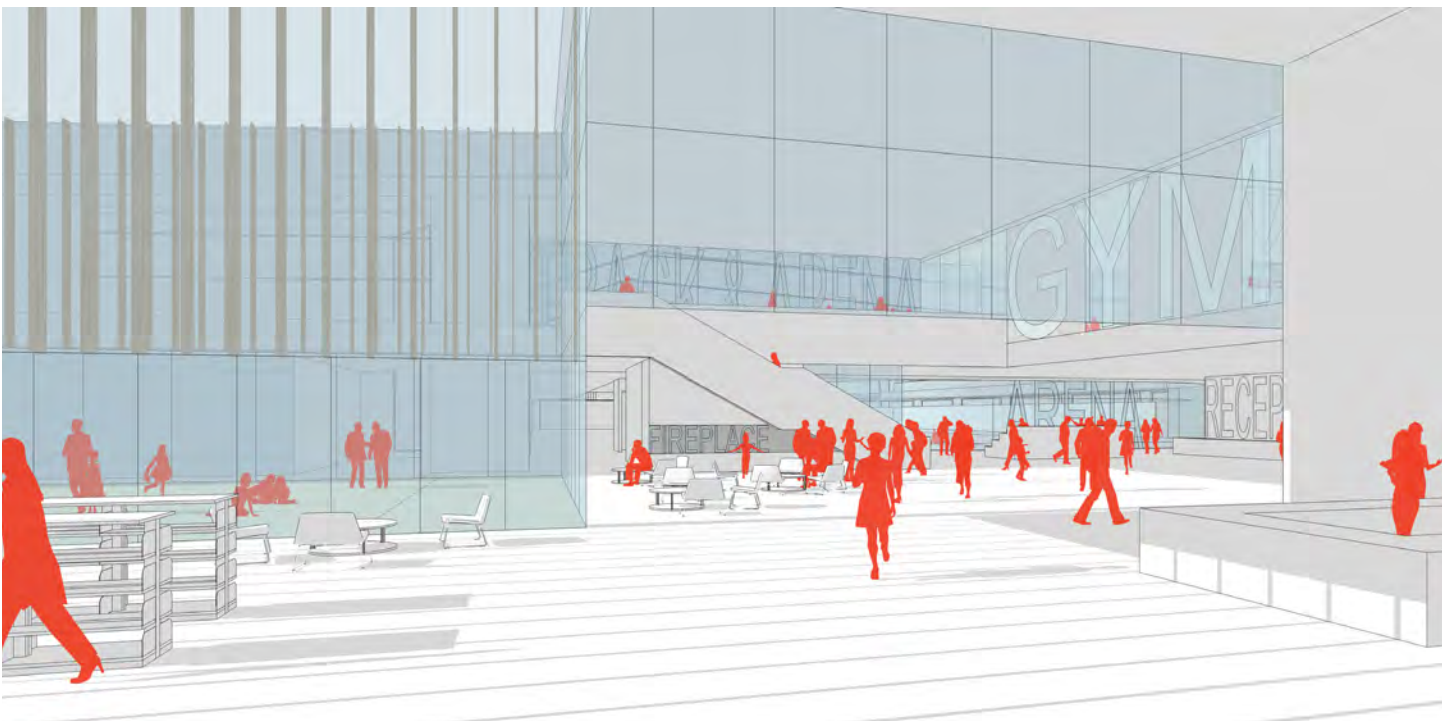

**INTERIOR VIEWS**





## **PROGRAMMING / RESEARCH**

**Project Program**

August 3, 2017

BUILDING		qty	Area	Total (sf)	Existing	Notes
<b>A Ice Rink</b>						
01	Ice Rink 1 (NHL)	1	22,000	22,000	19,700	85'x200'
02	Ice Rink 1 spectator area	1050	5	5,250		
03	Ice Rink 1 change rooms	5	650	3,250		barrier free, accessible, womens
04	Ice Rink 2 (NHL)	1	22,000	22,000	5,560	85'x200' (reduced from Olympic size)
05	Ice Rink 2 spectator area	175	5	875		
06	Ice Rink 2 change rooms	5	650	3,250	1,930	
07	Referee Room	1	200	200	57	
08	Coach Office	1	100	100		
09	Instructor Office	1	100	100	228	view into Rink 2 desired
10	First Aid	1	100	100	57	
11	Skate Rental/Repair	1	300	300		located with admin/reception?
12	Storage	1	1,500	1,500	1,175	
13	Sound Rooms	2	100	200		pa, scoreboard
14	Ice Resurfacer	1	2,000	2,000	752	
15	Ice Refrigeration/Mechanical	1	2,000	2,000	814	
	<b>Sub Total</b>			<b>63,125</b>	<b>30,273</b>	
<b>B Recreation</b>						
01	Gymnasium	1	11,000	11,000	5,700	1 HS court, 2 junior high courts
02	Gym spectator area	300	0	0		collapsible seating, included within gym area
03	Gym locker rooms	4	500	2,000	1,100	Could be two that are divisible. Showers.
04	Gym Office	1	100	100	180	no computer. Supervise gym play
05	Fitness Room/Dance Room	1	1,500	1,500		Combined room. performance floor and mirror/bar
06	Storage	1	500	500	201	
	<b>Sub Total</b>			<b>15,100</b>	<b>7,181</b>	
<b>C Library</b>						
01	Library	1	2,750	2,750		books, computer desk, checkout
02	Multi-Purpose Room	1	1,000	1,000		
03	Children Area	1	500	500		
04	Children Storage	1	50	50		
05	Checkout	1	0	0		within main library space
06	Meeting Rooms	3	180	540		2 at 200sf, 1 at 150sf. maker space, recording space
07	Staff Work Room	1	200	200		
08	Offices	1	125	125		
09	Shared work space	3	125	375		
10	Book Drop	1	70	70		
11	Staff Restroom	1	0	0		within overall building common area
12	Storage	1	300	300		
	<b>Sub Total</b>			<b>5,910</b>	<b>0</b>	
<b>D Community Center</b>						
01	Multi-Purpose Rooms	3	830	2,490	3,390	1 at 1000sf, 1 at 1500sf (with divider).
02	Art Room	1	1,000	1,000		
03	Preschool Rooms	4	900	3,600	1,400	4 rooms. 35sf/occ
04	Preschool restrooms	2	60	0	30	inc within above
05	Community Kitchen / Catering	1	400	400	297	sim to Fleetwood-Jourdain CC kitchen/Levy
06	Concession	1	300	300	175	Pop-up possible
07	Vending	1	150	150		
08	Admin Offices	6	150	900	987	
09	Admin Storage	1	250	250		
10	Support Facilities/Restrooms	1	1,500	1,500	54	family restroom. Mothers room
11	Lobby	1	0	0	624	see social space below
	<b>Sub Total</b>			<b>10,590</b>	<b>6,957</b>	
<b>E Building Sub Total</b>				<b>94,725</b>	<b>44,411</b>	
01	Running Track	1	6,000	6,000		within Rink 1 volume
02	Social Space/Main circulation			12,000	3,850	
03	Structure/Infrastructure/Mech	14%		15,780	7,339	
<b>BUILDING TOTAL</b>				<b>128,505</b>	<b>55,600</b>	



ROBERT CROWN COMMUNITY CENTER  
ICE COMPLEX AND LIBRARY

SITE		qty	Area	Total (sf)	Existing	Notes
<b>S</b>	<b>Total Site</b>			<b>702,600</b>	<b>702,600</b>	
01	Building Footprint			90,000	55,600	estimated building footprint
02	Parking/Drive/Drop-Off	225		85,000	59,600	per traffic/parking study
03	Tennis Courts	4	6,000	24,000	24,000	
04	Sports Fields	1	234,000	234,000	350,000	sport striping
	<b>Sub Total</b>			<b>433,000</b>	<b>489,200</b>	
	Landscape/Other	38%		269,600	213,400	subtotal - total site area
<b>SITE TOTAL</b>				<b>702,600</b>	<b>702,600</b>	

**Program Data Sheets**

August 14, 2017

A		01/04		Ice Rinks (NHL)			
area	44,000	nsf	existing	25,260	nsf	qty	2
<b>primary function</b>		<b>notes</b>		<b>floor finishes</b>			
NHL regulation size rinks. Hockey, figure Skating, speed skating, public skate		Be mindful of the visibility for accessible patrons. Keep the bars/rails out of the site lines.  Supervision of ice is primarily for Olympic Ice Rink. Not both.		Surfaces that skates would be allowed on, surfaces that don't allow skates, clear distinction between both			
<b>other functions</b>				<b>other finishes</b>			
shows and competitions				Netting affects visibility, lighting needs to be even (typical design for 750 fc, rinks for TV need 1000 fc), Subsoil heat is a necessity			
<b>adjacencies</b>				<b>equipment/installations</b>			
Warm up space, Locker rooms, storage, referee/judges rooms, party rooms (birthday party/multipurpose rooms)				Harnesses for figure skating.			
<b>systems</b>		<b>requirements</b>		<b>requests</b>			
Electronic scoreboards, A/V equipment for high quality sound, centralized refrigeration system, ice resurfacing equipment, integrated storage system for public skate storage, under-floor duct systems to accommodate future		sled hockey capability / adaptability		If natural light provided, space should have the capability of being blacked out. Hockey Folks say no to natural light, open to north facing light.			

A		02/05		Ice Rink Spectator Areas			
area	5,250	nsf	existing	0	nsf	qty	1050
<b>primary function</b>		<b>notes</b>		<b>floor finishes</b>			
seating audience for Rink 1		Locker room layout affects spectator seating quantity, sightlines, and distance from the ice. Seems like stepping down to ice is best on many levels (warm side corridor)		radiant heated floors			
<b>other functions</b>				<b>other finishes</b>			
shows and competitions				dasherboards/railings			
<b>adjacencies</b>				<b>equipment/installations</b>			
Locker rooms, Lobby/entrance, restrooms, concession area				netting  Benches only. Could have small 'upgraded' area with seats			
<b>systems</b>		<b>requirements</b>		<b>requests</b>			
Electronic scoreboards		provide ADA viewing locations		NHL rink could be designed for future expansion with the capability of doubling spectator seating and installing a central scoreboard system.			

ROBERT CROWN COMMUNITY CENTER  
ICE COMPLEX AND LIBRARY

A		03/06		Ice Rink Change Rooms			
area	6,500	nsf	existing	1,930	nsf	qty	10
<b>primary function</b>		<b>notes</b>		<b>floor finishes</b>			
provide lockers, changing areas, benches, showers and toilet facilities.		Skaters typically change in bathrooms – but bathrooms are too small. Wider corridors for figure skating shows would allow skaters to line up in hallways.		skate safe flooring			
<b>other functions</b>		<b>requirements</b>		<b>other finishes</b>			
A couple locker rooms should be fully accessible for sled hockey.  Provide female locker rooms		Could have 4 private – NU, Boys varsity, Girls varsity, Girls – with private showers and then other 8 use shared showers		hard surfaces, easily cleanable			
<b>adjacencies</b>				<b>equipment/installations</b>			
storage, referee/judges rooms, ice rink				Space to hang up equipment Permanent lockers are not required. Room for bags			
<b>systems</b>		<b>requirements</b>		<b>requests</b>			
HVAC - Locker Rooms need heavy ventilation to dry equipment, Showers are requirement in locker room		Parents are not supposed to go to locker room during event. Locker rooms should be “multi-purpose” and not just hockey focused. Some could be used by skating staff.		Dedicated lockers for permanent teams.			

A		07		Referee Room			
area	200	nsf	existing	57	nsf	qty	1
<b>primary function</b>		<b>notes</b>		<b>floor finishes</b>			
shared office for referee		Private staff and coaches bathroom/shower.		skate safe flooring			
<b>other functions</b>				<b>other finishes</b>			
				hard surfaces, easily cleanable			
<b>adjacencies</b>				<b>equipment/installations</b>			
ice rink, change rooms, private staff restrooms				Space to hang up equipment Permanent lockers? Room for bags			
<b>systems</b>		<b>requirements</b>		<b>requests</b>			
HVAC - Locker Rooms need heavy ventilation to dry equipment, Showers are requirement in locker room		1 per sheet		1 per sheet			

<b>A</b>	<b>10</b>	<b>First Aid</b>					
<b>area</b>		100	nsf	<b>existing</b>		57	nsf
							<b>qty</b> 1
<b>primary function</b>		<b>notes</b>		<b>floor finishes</b>			
first aide room							
<b>other functions</b>				<b>other finishes</b>			
<b>adjacencies</b>				<b>equipment/installations</b>			
ice rink, change rooms				medical cabinetry, cot refrigerator?			
<b>systems</b>		<b>requirements</b>		<b>requests</b>			

<b>A</b>	<b>11</b>	<b>Skate Rental/Repair</b>					
<b>area</b>		300	nsf	<b>existing</b>		0	nsf
							<b>qty</b> 1
<b>primary function</b>		<b>notes</b>		<b>floor finishes</b>			
counter for skate rentals, cashier, repair		Skate rental occurs at the administration/reception area too. Not a separate staff member					
<b>other functions</b>				<b>other finishes</b>			
				countertop, cubbies			
<b>adjacencies</b>				<b>equipment/installations</b>			
Entry, storage				point of sale skate sharpener?			
<b>systems</b>		<b>requirements</b>		<b>requests</b>			

ROBERT CROWN COMMUNITY CENTER  
ICE COMPLEX AND LIBRARY

<b>B</b>	<b>01</b>	<b>Gymnasium</b>					
<b>area</b>	11,000	nsf	<b>existing</b>	5,700	nsf	<b>qty</b>	1
<b>primary function</b>		<b>notes</b>			<b>floor finishes</b>		
1 High school court and 2 junior high courts. basketball, volleyball, indoor soccer and gymnastics		"Pulastic" used on recent MJMA project.  Pull out bleachers. 50-200 spectators typical,  Divider could be movable to create a-symmetric divisions			hardwood flooring or multi-sport rubber flooring		
<b>other functions</b>					<b>other finishes</b>		
multi-sport striping batting cage gymnasitics pre-school gross motor space							
<b>adjacencies</b>					<b>equipment/installations</b>		
team locker rooms, change rooms, staff office storage					fabric divider panel Provide collapsable spectator bleachers		
<b>systems</b>		<b>requirements</b>			<b>requests</b>		
		Needs to have a small office for supervision. Will likely not be staffed full-time but during peak times, would put a staff person here.			pickleball indoor soccer		

<b>B</b>	<b>03</b>	<b>Gym locker rooms</b>					
<b>area</b>	2,000	nsf	<b>existing</b>	1,100	nsf	<b>qty</b>	4
<b>primary function</b>		<b>notes</b>			<b>floor finishes</b>		
equipped with lockers, changing areas, benches, showers and toilet facilities.		Do not need "lockers". Need changing only?  Shower facilities could serve additional programs like fitness, dance, running track in the building.					
<b>other functions</b>					<b>other finishes</b>		
					countertop, cubbies		
<b>adjacencies</b>					<b>equipment/installations</b>		
Gym, restrooms					point of sale skate sharpener?		
<b>systems</b>		<b>requirements</b>			<b>requests</b>		

<b>B</b>	<b>05</b>	<b>Fitness Room/Dance Room</b>					
<b>area</b>	1,500	nsf	<b>existing</b>	0	nsf	<b>qty</b>	1
<b>primary function</b>			<b>notes</b>		<b>floor finishes</b>		
Fitness classes, group exercise, yoga, etc					hardwood flooring		
<b>other functions</b>					<b>other finishes</b>		
dance, warm-up					mirror wall, dance bar		
<b>adjacencies</b>					<b>equipment/installations</b>		
change rooms, lockers					AV, lighting to support fitness?		
<b>systems</b>			<b>requirements</b>		<b>requests</b>		

<b>C</b>	<b>01</b>	<b>Library</b>					
<b>area</b>	5,910	nsf	<b>existing</b>	0	nsf	<b>qty</b>	1
<b>primary function</b>			<b>notes</b>		<b>floor finishes</b>		
reading, job training (90-120 people), homework help/tutoring, presentations (75-100), book group (10-25), Tax preparation services (20-50) maker space			Should have a WOW factor See the library from the front door. Visible from the outside – separate identity, Staffing – clarity in circulation should lead to efficiency in staffing		Terrazzo, recycled rubber and carpet tile floor covering options to be priced for consideration, concentrating on durability, ease of cleaning and long term maintenance.		
<b>other functions</b>					<b>other finishes</b>		
Family Services, Space for a social worker Movies (perhaps in lobby?), Strong teen program, Musical practice room Pop-up computer class			Storage carts for laptops and tables and chairs to allow for pop-up computer classes and programs and flexible computer use by patrons throughout the space. Flat screen monitors and display surfaces to assist in marketing		Perhaps a desire for the space to be soft. Control acoustics Signage color coded, potentially on the floor, integral to the building design. Durable and easy to clean surfaces.		
<b>adjacencies</b>					<b>equipment/installations</b>		
Kiosk for book checkout, Library vending machine, Kiosks in the lobby with laptops. Social worker desk. Staff office or work space. Restrooms, storage for skating equipment/outdoor equipment			Extensive glazing should be provided between the library and reading garden spaces containing an integrated retractable door system capable of creating an indoor/outdoor environment.		Higher shelving around perimeter and lower shelving throughout to provide for books, materials and magazines.  Printers. Copiers. Scanners. Wireless printing. Storage space – for extra books, extra laptops. Drop box		
<b>systems</b>			<b>requirements</b>		<b>requests</b>		
Zoned HVAC and power, Extensive power and data with strong Wi-Fi connection throughout. Electrical and USB outlets adjacent to seating and study areas for visitors who bring their own devices, under-floor duct systems to accommodate future power and data needs			Strong wireless. Wifi Blanket the facility.		Flexible walls. Bookstacks on wheels. Mobile furniture. Buffer space/layers – modifying behavior, natural, green, trees, colored, pods. Where/how could hockey bags be stored? Dematerialized border of library.		

ROBERT CROWN COMMUNITY CENTER  
ICE COMPLEX AND LIBRARY

<b>C</b>	<b>03</b>	<b>Children Area</b>						
<b>area</b>		500	nsf	<b>existing</b>		0	nsf	<b>qty</b>
								1
<b>primary function</b>			<b>notes</b>			<b>floor finishes</b>		
books, reading area, circle time			one chair that a family of three can sit in, living room					
			linens, activity equipment, first aid box?					
<b>other functions</b>						<b>other finishes</b>		
pre-school use?						Sound dampening features to moderate noise levels when surrounded by hard surfaces and to acoustically isolate the library from other portions of the building.		
<b>adjacencies</b>						<b>equipment/installations</b>		
circulation desk, storage, maker space								
<b>systems</b>			<b>requirements</b>			<b>requests</b>		

<b>C</b>	<b>05-12</b>	<b>Library Staff/Work Areas</b>						
<b>area</b>		770	nsf	<b>existing</b>		0	nsf	<b>qty</b>
								1
<b>primary function</b>			<b>notes</b>			<b>floor finishes</b>		
Staff work rooms and storage, circulation desk			Staff size – full time librarian, 2 shelvers, 2 associates or clerks, Collaborative librarian – 2 chairs, Separate space for specific work.					
<b>other functions</b>			Workroom and part time employees can be in common room. Head Librarian is only person who needs private office			<b>other finishes</b>		
			The book drop will be publicly accessible when the Crown Center is open and the Library is closed.					
<b>adjacencies</b>						<b>equipment/installations</b>		
Library Entry, Storage. Clear views to entire library						Key card access. Point of Sale?		
<b>systems</b>			<b>requirements</b>			<b>requests</b>		
Key card access.						Book return to have multiple slots for 'pre sorting'		

<b>D</b>	<b>01/02</b>	<b>Multi-Purpose Rooms / Art Room</b>							
<b>area</b>		3,490	nsf	<b>existing</b>		3,390	nsf	<b>qty</b>	3
<b>primary function</b>		<b>notes</b>			<b>floor finishes</b>				
Community Meeting Space Pottery program/Art room Rental/Party Space		Designed to accommodate a variety of community programming. This room shall be a minimum of 900 square feet in size and shall include a kiln, sink and drying racks for pottery activities.			Cleanability/Durability				
<b>other functions</b>					<b>other finishes</b>				
Library would use if available to extend their programming. Costume and Set construction for Ice Show pre-function space for events					Cleanable.				
<b>adjacencies</b>		<b>requirements</b>			<b>equipment/installations</b>				
ciurculation desk, lobby, ice rink, library		connected storage for each			provide dividing wall in larger MP room to make two smaller rooms.  Counters and sinks.				
<b>systems</b>		<b>requests</b>							
					Kiln?				

<b>D</b>	<b>03/04</b>	<b>Pre-School</b>							
<b>area</b>		3,600	nsf	<b>existing</b>		1,430	nsf	<b>qty</b>	4
<b>primary function</b>		<b>notes</b>			<b>floor finishes</b>				
Fully licensed pre-school 2yr Old Room, 3-5yr old room, (2) aftercare sized rooms		(IDHS) license required elements such as access control and dedicated restroom facilities.  Pre-School has 20 part time staff. 150 staff during summer camp.			outdoor classroom would be nice. Washington school could use RCCC for after school programming and would utilize the library				
<b>other functions</b>					<b>other finishes</b>				
					Cleanable. Washington School uses the east end of the site for recess/outdoor play. Would prefer natural grass. Window shades for nap time.				
<b>adjacencies</b>		<b>requirements</b>			<b>equipment/installations</b>				
Library, exterior reading/play space, lobby		secured entry washer/dryer separate kitchenette/refrigerator			window shades hose bibb for outdoor activities (fillig up mini pools)				
<b>systems</b>		<b>requests</b>							
					Paper towels, not hand driers required. Indoor playground would be nice for winter/bad weather. Picnic or eating space for camps? Having access to pre-school play equipment in the gymnasium/MP room for birthday parties would be nice.				



ROBERT CROWN COMMUNITY CENTER  
ICE COMPLEX AND LIBRARY

<b>D</b>	<b>05</b>	<b>Community Kitchen / Catering</b>					
<b>area</b>		400	nsf	<b>existing</b>		297	nsf
							<b>qty</b>
							1
<b>primary function</b>		<b>notes</b>		<b>floor finishes</b>			
Kitchen instruction, support food service, catering, events		The kitchen shall be capable of supporting daily use such as lunch service for preschool programs as well as private rental events for up to 300 people. The kitchen will be similar in size to the kitchen at the Fleetwood-Jourdain					
<b>other functions</b>		<b>other finishes</b>		<b>equipment/installations</b>			
		Concessions often an issue – where is the line where skates are not allowed on the floor?					
<b>adjacencies</b>		<b>requirements</b>		<b>requests</b>			
lobby, pre-school, library		vending shall be provided at logical locations in the facility and shall include both food and skating supplies such as tape and mouth guards.					
<b>systems</b>							
black iron needed?							

<b>D</b>	<b>08/09</b>	<b>Administration / Reception</b>					
<b>area</b>		1,150	nsf	<b>existing</b>		987	nsf
							<b>qty</b>
							1
<b>primary function</b>		<b>notes</b>		<b>floor finishes</b>			
general office functions as well as a registration desk. include a minimum of five private offices for building and program management.		Shall provide clear viewing of all incoming and exiting facility users as well as direct views to both rinks for security purposes. A security camera system can be used to supplement visual observation needs if required.					
<b>other functions</b>		<b>other finishes</b>		<b>equipment/installations</b>			
<b>adjacencies</b>		<b>requirements</b>		<b>requests</b>			
Entry, skate rental. Clear view of most program spaces View of exterior/drop-off/sportsfields		secured entry washer/dryer separate kitchenette/refrigerator		close with door or shutter at night when not staffed			
<b>systems</b>							

<b>S</b>	<b>02</b>	<b>Parking/Drive/Drop-Off</b>					
<b>area</b>	85,000	nsf	<b>existing</b>	59,600	nsf	<b>qty</b>	225
<b>primary function</b>		<b>notes</b>		<b>floor finishes</b>			
parking for 225 vehicles, drop-off		2-4 busses would arrive for summer camps (and wait in parking lot) Washington School uses east end of RCC parking lot for drop off/pickup		permeable pavers? Asphalt			
<b>other functions</b>		<b>notes</b>		<b>other finishes</b>			
Bike Parking		Teams arrive with trucks of equipment. Preschool staff: Most take public transportation. Perhaps use 10 parking spaces in the lot.		bioorientation			
<b>adjacencies</b>		<b>requirements</b>		<b>equipment/installations</b>			
entry, sportsfields				lighting			
<b>systems</b>		<b>requirements</b>		<b>requests</b>			
				Concern about traffic on Lee. Do not exit parking lot onto Lee St. Desire for bike friendly park. Bad traffic at Dodge and Lee. Left turn very difficult during time of high traffic. No crosswalk.			

<b>S</b>	<b>04</b>	<b>Sports Fields</b>					
<b>area</b>	234,000	nsf	<b>existing</b>	350,000	nsf	<b>qty</b>	1
<b>primary function</b>		<b>notes</b>		<b>floor finishes</b>			
outdoor athletics. 70 and 90ft baseball, (2) 11v11 soccer fields, (1) football/lacross/soccer field.		70' baseball/softball typical AYSO uses 6-8 fields on Sundays. 5yr olds to 8v8 12 yr olds. Need ability to have 7-8 games. Shared facilities with Washington School work great.		multi-sport striping, turf, containment along dodge, rainwater collection			
<b>other functions</b>		<b>notes</b>		<b>other finishes</b>			
<b>adjacencies</b>		<b>requirements</b>		<b>equipment/installations</b>			
Park shelters/facilities in the park. Exterior storage, Spectator space for each competition. Concessions, restrooms, vending mach.				Lighting, netting, backstops bleachers?			
<b>systems</b>		<b>requirements</b>		<b>requests</b>			
Scoreboards, PA system not required				exterior restroom area near fields			



**LEED v4 for BD+C**  
**New Construction and Major Renovation**  
Project Checklist

Project Name: Robert Crown Community Center Ice Complex Library  
Date: 8/2/2017

Y	?	N			
1			Credit	Integrative Process	1
<b>8</b>	<b>0</b>	<b>8</b>	<b>Location and Transportation</b>		<b>16</b>
			Credit	LEED for Neighborhood Development Location	16
1			Credit	Sensitive Land Protection	1
		2	Credit	High Priority Site	2
5			Credit	Surrounding Density and Diverse Uses	5
		5	Credit	Access to Quality Transit	5
1			Credit	Bicycle Facilities	1
		1	Credit	Reduced Parking Footprint	1
1			Credit	Green Vehicles	1
<b>6</b>	<b>1</b>	<b>3</b>	<b>Sustainable Sites</b>		<b>10</b>
Y			Prereq	Construction Activity Pollution Prevention	Required
1			Credit	Site Assessment	1
		2	Credit	Site Development - Protect or Restore Habitat	2
		1	Credit	Open Space	1
3			Credit	Rainwater Management	3
2			Credit	Heat Island Reduction	2
	1		Credit	Light Pollution Reduction	1
<b>6</b>	<b>3</b>	<b>2</b>	<b>Water Efficiency</b>		<b>11</b>
Y			Prereq	Outdoor Water Use Reduction	Required
Y			Prereq	Indoor Water Use Reduction	Required
Y			Prereq	Building-Level Water Metering	Required
1	1		Credit	Outdoor Water Use Reduction	2
3	1	2	Credit	Indoor Water Use Reduction	6
1	1		Credit	Cooling Tower Water Use	2
1			Credit	Water Metering	1
<b>18</b>	<b>4</b>	<b>11</b>	<b>Energy and Atmosphere</b>		<b>33</b>
Y			Prereq	Fundamental Commissioning and Verification	Required
Y			Prereq	Minimum Energy Performance	Required
Y			Prereq	Building-Level Energy Metering	Required
Y			Prereq	Fundamental Refrigerant Management	Required
3		3	Credit	Enhanced Commissioning	6
8	4	6	Credit	Optimize Energy Performance	18
		1	Credit	Advanced Energy Metering	1
2			Credit	Demand Response	2
2		1	Credit	Renewable Energy Production	3
1			Credit	Enhanced Refrigerant Management	1
2			Credit	Green Power and Carbon Offsets	2

<b>4</b>	<b>1</b>	<b>8</b>	<b>Materials and Resources</b>	<b>13</b>
Y			Prereq Storage and Collection of Recyclables	Required
Y			Prereq Construction and Demolition Waste Management Planning	Required
		5	Credit Building Life-Cycle Impact Reduction	5
1		1	Credit Building Product Disclosure and Optimization - Enviro Product Declarations	2
1		1	Credit Building Product Disclosure and Optimization - Sourcing of Raw Materials	2
1		1	Credit Building Product Disclosure and Optimization - Material Ingredients	2
1	1		Credit Construction and Demolition Waste Management	2

<b>7</b>	<b>2</b>	<b>7</b>	<b>Indoor Environmental Quality</b>	<b>16</b>
Y			Prereq Minimum Indoor Air Quality Performance	Required
Y			Prereq Environmental Tobacco Smoke Control	Required
1		1	Credit Enhanced Indoor Air Quality Strategies	2
3			Credit Low-Emitting Materials	3
1			Credit Construction Indoor Air Quality Management Plan	1
1	1		Credit Indoor Air Quality Assessment	2
		1	Credit Thermal Comfort	1
1		1	Credit Interior Lighting	2
		3	Credit Daylight	3
		1	Credit Quality Views	1
	1		Credit Acoustic Performance	1

<b>1</b>	<b>1</b>	<b>4</b>	<b>Innovation</b>	<b>6</b>
	1	4	Credit Innovation	5
1			Credit LEED Accredited Professional	1

<b>1</b>	<b>0</b>	<b>3</b>	<b>Regional Priority</b>	<b>4</b>
		1	Credit Regional Priority: Specific Credit	1
1			Credit Regional Priority: Specific Credit	1
		1	Credit Regional Priority: Specific Credit	1
		1	Credit Regional Priority: Specific Credit	1

<b>52</b>	<b>12</b>	<b>46</b>	<b>TOTALS</b>	Possible Points: <b>110</b>
-----------	-----------	-----------	---------------	-----------------------------

Certified: 40 to 49 points, Silver: 50 to 59 points, Gold: 60 to 79 points, Platinum: 80 to 110



RELEVANT EVANSTON CODES

YR	Code	Notes
2012	IBC	
2012	NFPA Life Safety Code 101	
2012	International Fire Code	
2014	Illinois Plumbing Code	Fixture Calculation. Eighteen lineal inches of wash sink or 18 inches of a circular basin, when provided with water outlets for the space, shall be considered equivalent to one lavatory. (See Appendix F, Illustration B.)
		Lavatories required by Appendix A: Table B shall be installed in restrooms at a ratio of not less than one lavatory per two water closets or urinals. (See Footnote 2, Appendix A: Table B.) All restroom facilities must comply with designation requirements set forth in Section 2902.2 of the International Building Code, adopted by City Code Section 4-2-2 of the City of Evanston.
		Approved automatic sprinkler systems shall be installed in all new buildings and structures with a Group I or R area. Approved automatic sprinkler systems shall be installed in all new buildings and structures with any other occupancy classification that exceeds 5,000 square feet in area. The building area shall be defined in accordance with Section 202 and include each story.
2011	National Electrical Code	
2012	International Energy Conservation Code	
2012	International Mechanical Code	
2010	ADA	
	Illinois Accessibility Code	
	Evanston Sign Regulations	
	Design and Project Review Committee	Will be required - 1. new construction. 2. zoning variations(?). 5. Municipal/public development. 7. Development using public financing. -Concept Design and Project Review -Preliminary Design and Project Review -Final Design and Project Review

**Robert Crown Community Center Ice Complex and Library**  
**1701 Main Street, Evanston, IL 60202**

ITEM	ISSUE	CHAPTER/ARTICLE	Ordinance Rqmt	Actual	REMARKS
<b>ZONING REQUIREMENTS</b>					
	Zoning District	6-7-1	Open Space District (OS)	OS	R4 west of Dodge, R3 north, south, east of site, C1 at SW corner of Main/Dodge
	Municipal Use Exemption	6-7-4	Any use allowed in any District if owned by City		not required as Rec Center is allowed within OS District. Perhaps needed for reduction to parking lot?
	Permitted Uses	6-15-9-2	Community Center - Public Recreation Center - Public Park	same	
	Min Lot Size	6-15-9-4	20,000 sf	702,600 sf	area within property line, does not include sidewalk/parkway. Total site area = 757,000sf
	Min Lot Width	6-15-9-5	25 ft	587 ft (n/s) 1,197 ft (e/w)	dimensions of property line, does not include sidewalk/parkway.
	Maximum Floor Area Ratio	6-15-9-6	0.15	0.186	90,000 1st floor + 35,000 2nd floor = 125,000sf 105,390 allowed.
	Building Height	6-15-9-7	35 ft	47 ft	confirm what this is measured to
	Size of Parking Stalls	6-16-2-4	8'-6" x 18' (non-parallel) 8' x 21' (parallel)	will comply	
	Size of HC Parking Stalls	6-16-2-6	16' x 18'	will comply	
	Off Street Parking Layout	6-16-2-7	See Illustration for dimensions	will comply	
	Parking Requirements	6-16-3	-Gym/Sports Arena = 1/10 total seating capacity -Daycare = 1 per ea employee + 1 per ea company vehicle + 1/15 children -Swimming Pool or Skating Rink = 1/10 persons of capacity -Recreation Facility = 2 per 1000 GSF + 1 per 3000 GSF for outdoor recreation	225  Per Traffic and Parking Study	Assuming non-overlapping occupancies, us Rec Center as basis for count.  Rec Center = 125,000 sf = 250 spaces Outdoor Fields = 234,000 sf = 81 spaces Total = 331 spaces
	Handicapped Parking	6-16-3	101-150 = 5 151-200 = 6 201-300 = 7 301-400 = 8	7 provided	8 required per code. 7 required if based on 225 total spaces.
	Off Street Loading Size	6-16-4-4	10' x 35' = short berth	will comply	
	Off Street Loading Vertical Clearance	6-16-4-5	14 ft	will comply	
	Off Street Loading Req'd	6-16-5	Rec Center not listed	1 provided	Confirm w/ City what is req'd
<b>BUILDING REQUIREMENTS</b>					
	Occupancy Classifications	302.1	Assembly Educational	A-3 = Gym A-3 = Library A-4 = Arena A-4 = Skate Rink E = Daycare	
	Area Limits	503 (table)	Type I-B = UL	130,000	
	Height Limits	503 (table)	Type I-B = 11 Stories	2	2 stories, max
	-Sprinkler Increases	506.3	200% INCREASE	N/A	NOT UTILIZED
	Mezzanine Area Limits	505.2.1	1/3 floor area below max		1/2 floor area allowed in Type-I construction if sprinklered.
	Mixed Use Area Limits	508.2.1	10% of area per story		seperation not required.
	Occupancy Separations	508.4 (table)	None req'd between A & E uses 1 HR between A, E & B uses		Confirm separation requirements
	Construction Type	602.1	TYPE I-B	TYPE I-B	
	Req.Hrs of Fire Resistance	601 (table)	SEE BELOW		
	-Primary Structure Frame	601 (table)	2 HR	-	1 HR for primary structure frame and bearing walls when supporting roof only
	-Exterior Bearing Walls	601 (table)	2 HR	-	
	-Interior Bearing Walls	601 (table)	2 HR	-	1 HR for primary structure frame and bearing walls when supporting roof only
	-Nonbearing Exterior Walls	601 (table)	per table 602	-	
	-Nonbearing Interior Walls	601 (table)	0 HR	-	
	-Floor Construction	601 (table)	2 HR	-	
	-Roof Construction	601 (table)	1	-	No fire proofing req'd when roof is min 20ft above floor below

Combustible Materials Allowed in I-B	603.1.1	Fire Treated wood = Roof Construction		
Shaft Enclosures	713.4	2 HR		
Interior Wall and Ceiling Finishes	803.9	B - Interior Exit Stairs B - Corridors C - Rooms/exposed spaces		For A-3 and A-4, sprinklered
Furred Construction	803.11.1	Direct applied to non-combustible construction or 1-3/4" max furring		SPRINKLER SYSTEM PROVIDED
Furred Construction	803.11.1.1	Space between furring to be filled w/ non-combustible material or fireblocked at max 8ft in every direction		
Decorative Materials/Trim	806.1	non-combustible or meeting NFPA 701 for all curtains, draperies, decorative materials		
Sprinkler System Req'd - A-3	903.2.1.3	Required if +12,000sf or +300 occ or if on floor other than level of exit discharge	provided	
Sprinkler System Req'd - A-4	903.2.1.4	Required if +12,000sf or +300 occ or if on floor other than level of exit discharge	provided	
Fire Extinguishers	906.1	Required in Group A uses. And within 30ft of commercial cooking		
Size and Distribution of Fire Extinguishers	906.3			confirm spacing. Typically every 75ft

#### EXIT REQUIREMENTS

Min Ceiling Ht	1003.2	7'-6"		
Fixed Seat Occupant Load	1004.4	Determined by total number of fixed seats. If a bench, use 1occ/18" of bench length		
Occupant Load Calc	1004.1.2	Storage = 1/300sf Assembly, Standing Room = 1/5sf Assembly, Concentrated = 1/7sf Assembly, Unconcentrated = 1/15sf Business/Office = 1/100sf Day Care = 1/35sf Classroom = 1/20sf Exercise Rooms = 1/50sf Library, Reading Rooms = 1/50sf Library, Stacks = 1/100sf Locker Rooms = 1/50sf Skating Rinks = 1/50sf		
Stairway Exit Width	1005.3.1	0.2 inches per occupant (when sprinklered)		
Door Exit Width	1005/3/2	0.15 inches per occupant (when sprinklered)		
Door Encroachment	1005.7.1	7" MAX		
Area of Rescue Assistance	1007.3.2	Not required if sprinklers provided		
Panic Hardware Req'd	1008.1.10	Doors serving rooms with occ load 50+		
Interior Exit Stairways	1009.2	must lead directly to the exterior. Must be enclosed.		
Exit ACCESS stairways	1009.3	Must be enclosed, except: if sprinklered.		allowed to be open. Is an ACCESS stairway only, not egress.
Stair Width	1009.4	44" min 36" min if occ <50		
Stair Headroom	1009.5	80" min		
Guards Req'd	1013.2	On all surfaces w/ 30" open drop		
Guards	1013.3	42" MIN		
Guard Opening Limits	1013.4	4" SPHERE		
Number of Exits	1015.1.1	501-1000 occ = 3 exits from room +1000 occ = 4 exits from room		
Travel Distance	1016.2	Group A = 250ft (when sprinklered)		
Corridor Fire Rating	1018.1	Group A = occ>30 = 0 HR (when sprinklered)		
Minimum Corridor Width	1018.2	44" MIN		
Dead End Corridor	1018.4	20ft		no exception for Group A use



ROBERT CROWN COMMUNITY CENTER  
ICE COMPLEX AND LIBRARY

Min Number of Exits	1021.2	2 per floor		
3 or more Exits Req'd	1021.2.4	Three exits, or <b>exit access stairways</b> or ramps <b>providing access to exits at other stories</b> , shall be provided from any story or occupied roof with an occupant load from 501 to and including 1,000. Four exits, or exit access stairways or ramps providing access to exits at other stories, shall be provided from any story or occupied roof with an occupant load greater than 1,000.		Per conversation with Evanston, the ACCESS stair (see section 1009.3) - can be used as one of the means of egress from the second floor with a high occupancy since it provides access to exits at "other stories" (ie: it leads directly to the front door) as long as the total exit travel distance is within the limits.
Exit Discharge	1027.1	Exits shall discharge to exterior of the building. Exception allowed for 50% number and capacity of exits if following is met 1. visible exit door, direct path, clear of obstructions. 2. entire area of level of discharge is protected from areas below with rating to match stair 3. sprinkler systems throughout		Egress from Library could exit out to lobby and then outside. Combined with open stair, it cannot be more than 50% of total egress.
Assembly Main Exit	1028.2	In assembly space with +300 occ, the main exit must accommodate 50% of the total occ		confirm during design
Aisle Rows	1028.8.1	No more than 24 seats between 2 aisles		
Min Aisle Width	1028.9.1	48" for aisle stairs w/ seating on both sides 36" for aisle stairs w/ seating on one side		review exceptions during design

**PLUMBING REQUIREMENTS**

Water Closets	Table 2902.1			See next page
Lavatories	Table 2902.1			See next page
Drinking Fountains	Table 2902.1			See next page
Service Sink	Table 2902.1			See next page
Unisex Restroom	Table 2902.1	one per floor to be included		

**SIGN REGULATIONS**

Max Area	4-10-9.D	10% of façade area or 0.5% of lot area		
Max Height	4-10-9.H	15.5ft		
Free Standing Sign	4-10-10.B	Only 1 per site		
Free Standing Sign	4-10-10.B	min 3ft from any lot line		
Free Standing Sign	4-10-10.B	120 sf total area		
Scoreboards	4-10-10.H	no scoreboard shall be erected such that it is visible from a public thoroughfare		

**OCCUPANT LOAD**

No.	ROOM NAME	AREA	AREA PER	OCC LOAD	NOTES
LEVEL 1					
	RINK 1	16,300	50	326	based on actual use, not area
	RINK 2	16,300	50	326	based on actual use, not area
	RINK 2 SPECTATORS		seats	175	
	RINK CHANGE ROOMS	6,500	inc	0	
	PRESCHOOL	3,600	35	103	
	ADMIN	900	100	9	
	LIBRARY READING ROOM	4,000	50	80	
	LIBRARY MEETING/MP SPACE	1,600	20	80	
	LIBRARY WORK SPACE	750	100	8	
	MULTI-PURPOSE	1,500	15	100	
	MECHANICAL/BACK OF HOUSE	8,500	300	29	
	LOBBY	7,000	inc	0	
				1,236	

LEVEL 2					
	RINK 1 SPECTATORS		seats	1,050	
	TRACK	5,750	50	115	
	MULTI-PURPOSE	1,000	inc	0	
	ADMIN	1,000	100	10	
	CHANGE ROOMS	1,300	inc	0	
	FITNESS ROOM	1,500	50	30	
	ART ROOM	1,000	20	50	
	GYM	12,000	20	499	posted occ. Limit to 2 doors
	GYM SEATING (300)		inc	0	
				1,754	

TOTAL OCCUPANT LOAD

2,990

**PLUMBING FIXTURE CALCULATIONS**

		IBC 2012 (A-4 Use)			
		rule	Men	Women	rule
occupancy			1495	1,495	
water closets	1 per 75 to 1500, then 1 per 120		20	38	1 per 40 to 1520, then 1 per 60
				58	
lavatories	1 per 200		8	10	1 per 150
				18	
drink fountain	1 per 1000		3		
service sink	1 per floor		2		

		Illinois Plumbing Code-Assembly			
		rule	Men	Women	rule
			1495	1495	
water closets	10: 400-800, then 1 per 700		11	49	44:651-800, then 1 per 150
				60	
lavatories	6: 401-750, then 1 per 400		8	8	6: 401-750, then 1 per 400
				16	
restroom	1 per restroom		4		
service sink	1 per floor		2		

Table 8

**PROJECTED PEAK PARKING DEMAND - ANTICIPATED PARK PROGRAMMING AND STAFFING SCHEDULES (3 SOCCER FIELDS)**

Activity	Participants/ Visitors	Coaches/ Volunteers	Program Staff/ Referees	Total	Parking Demand							
					Winter		Weekday	Spring/Summer/Fall		Sunday		
					Weekday	Saturday		Weekday	Saturday			
					5:00-6:00 PM	3:00-4:00 PM	5:00-6:00 PM	3:00-4:00 PM	3:00-4:00 PM	2:00-3:00 PM		
Fitness/Dance Room <sup>1</sup>	25		1	26	18	18	18	18	18	18		
Walking/Jogging Track <sup>1</sup>	10			10	7	7	7	7	7	7		
Art Room <sup>1</sup>	15		1	16	11	11	11	11	11	11		
<b>Ice Rink (NHL &amp; Olympic Rinks)</b>												
Main Rink Games <sup>1,2</sup>	60	8	2	70	25	47	25	47	47	47	0	
Olympic Rink Practices/Skating Classes <sup>1,3</sup>	15	2	2	19	8	8	8	8	8	8	0	
<b>Gymnasium (1 HS Court or 2 Jr HS Courts)</b>												
Basketball Games <sup>1,4</sup>	96	8	8	112	0	77	0	77	0	0	0	
Open Gym <sup>1,3</sup>	50		1	51	18	0	18	18	18	18	18	
Multi-Program Rooms (Party) <sup>1,3,5</sup>	50		1	51	0	0	0	0	0	0	18	
Library <sup>1,6</sup>	50		5	55	38	38	38	38	38	38	0	
Preschool/After-School <sup>7</sup>	84		25	109	53	0	53	0	53	0	0	
Admin/Maintenance staff			5	5	5	5	5	5	5	5	5	
<b>Outdoor Baseball/Soccer Games</b>												
Baseball Games <sup>1,3,8</sup>	120	16	3	139	0	0	0	0	0	48	0	
Soccer Games <sup>1,3,9</sup>	180	24	9	213	0	0	43	0	0	0	77	
<b>Peak Demand</b>					<b>182</b>	<b>212</b>	<b>225</b>	<b>200</b>	<b>153</b>			

<sup>1</sup> An auto occupancy of 1.5 people/car was assumed.  
<sup>2</sup> Assumes 15 players/team, 2 teams/game, 2 coaches/team, 2 referees/game, 2 teams in locker room (except weekdays when first game/practice starts after 6:00 PM).  
<sup>3</sup> Assumes 1/2 participants are dropped-off/picked-up without parking or park on the street.  
<sup>4</sup> Assumes 12 players/team, 2 teams/court, 2 coaches/team, 2 referees/game, 1 scorekeeper/game, 1 clock keeper/game, 4 teams in locker room; Assumes basketball games do not overlap with open gym times.  
<sup>5</sup> Staff indicates birthdays parties are scheduled on weekends and typically include a public skate session, which do not run concurrent with hockey games/practices. With the exception of Sunday afternoon, the parties occur at off-peak times and the parking demand from the parties was not factored into the peak parking loads shown in this table.  
<sup>6</sup> Patronage and staffing provided by Evanston Public Library based on programming data from the Chicago Ave./Main St. and North Branch library locations.  
<sup>7</sup> Assumes a maximum of 1/3 of student pick-up vehicles are on-site at the same time  
<sup>8</sup> Assumes 15 players/team, 2 teams/game, 2 fields in use, 4 teams waiting, 2 coaches/team, 1 umpire/game, 1 floating staff member, 4 teams waiting to play (except weekdays when first game/practice starts after 5:45 PM); Assumes no games in Winter.  
<sup>9</sup> Assumes 15 players/U13+ team, 2 teams/game, 2 umpires/game, 1 staff attendee/field; Assumes no games in Winter and Summer, and assumes use of fields for soccer do not overlap with use of fields for baseball.

## 7.

# Conclusions and Recommendations

---

Based on the proposed Robert Crown Park redevelopment plan and the preceding Traffic and Parking Study, several conclusions and recommendations are made.

### Conclusions

- Robert Crown Park is centrally-located within the City of Evanston and is accessible from two major roadways (Main Street and Dodge Avenue), several local roads, two CTA bus routes (Routes 93 and 206), bicycle facilities on Dodge Avenue and Main Street, and the local sidewalk system.
- The redevelopment of Robert Crown Park will consist of the replacement of the Robert Crown Center with a larger approximately 127,230-square foot facility, an expanded parking lot, and an upgrade of the outdoor sports fields with synthetic turf. The new building will include a larger gymnasium, a running track, a fitness/dance room, an art room, a branch library, more preschool/after-school space, and a second full-size hockey rink.
- Access driveways to the parking lot are proposed to continue to be provided from the same general locations on Main Street. With the new facility relocated to the southwest corner of the Park, the initial concepts anticipate that the west access drive will become more of the primary entry drive due to its proximity to the building, and is therefore proposed to be modified to allow both ingress and egress whereas the current west driveway is only used for egress. The east access drive is proposed to continue to be used for ingress and egress.
- Building servicing/loading will occur at the northeast corner of the building from a new service drive off Lee Street.
- This study evaluated the incremental growth in peak-hour traffic over existing traffic conditions based on changes in programming on the site.
- Program changes that will result in the most significant traffic increases on the site include the branch library, expanded preschool and after-school space, fitness/dance room, expanded gymnasium, and running track.
- The new ice rinks are not anticipated to generate traffic significantly different than the current rinks generate as the seating capacity of the new main rink will be generally the same as the current main rink and will continue to host similar events, and the new NHL-size ice

rink that will replace the current studio rink is proposed to continue to be used as a secondary rink for EYHA hockey practices/games with only loose bench seating for spectators.

- Future programming of the reconfigured sports fields is also not expected to generate significant volumes of additional traffic during the peak periods beyond what is already occurring on-site as the two baseball diamonds will continue to be used for EBSA games on weekday evenings and Saturdays and the reconfigured soccer fields will continue to be used for AYSO games on Sundays. The soccer fields may even result in a small traffic reduction as the number of participants on-site at any given time may be reduced depending on the field arrangement.
- It should be noted, however, that use of the fields may be scheduled earlier and/or later in the season than currently scheduled, which would increase traffic on days of the year when the fields are currently not programmed.
- The peak hour periods evaluated included the peak activity times on a typical weekday (8:15-9:15 A.M., 5:00-6:00 P.M.) and Saturday (11:45 A.M.-12:45 P.M.) at the Robert Crown Center and Park. The weekday peak times coincide with the morning and evening commuter “rush” hours. The Saturday peak time coincides with the midday period when weekend traffic volumes on the adjacent roadway system are typically at high levels.
- The new branch library at the Robert Crown Center is proposed to have the same operating hours as the other Evanston Public Library branches. These branches do not open until 10:00 A.M., so do not impact the morning rush hour, and are closed on Thursdays and Sundays.
- Westbound traffic flow on Main Street currently backs up from the Dodge Avenue intersection past the Robert Crown Center’s west access drive during the weekday evening peak hour and Saturday midday period. Stopped motorists typically provide courtesy gaps for vehicles exiting the Park.
- Southbound traffic flow on Dodge Avenue currently backs up from the Main Street intersection past Lee Street during the weekday evening peak hour and Saturday midday period. Stopped motorists typically provide courtesy gaps for vehicles turning from Lee Street.
- All study area intersections currently operate at satisfactory levels of service (D or better) during the weekday and Saturday peak hours under the current traffic control.
- With the additional traffic generated by the Robert Crown Park redevelopment program, all intersections will continue to operate at the same levels of service during the peak hours. However, the traffic queues at the Main Street/Dodge Avenue intersection will be extended by one or two cars and could impede traffic movements to and from the west access drive on Main Street, and to and from Lee Street, if improvements are not made to the Main Street/Dodge Avenue intersection.
- Surveys of the Robert Crown Center parking lot indicated that the current peak parking demand ranged from 97 spaces on a weekday to 119 spaces on a Sunday, which was adequately accommodated by the existing 147-space parking lot.

- Surveys of the street parking surrounding Robert Crown Park indicated that peak utilization of the spaces ranged from 39% of capacity on weekdays to 55% of capacity on Sundays.
- The new Robert Crown Center has a projected peak parking demand of 212 spaces for the site plan options that include two full-size soccer fields.
- For a site plan option that includes three full-size soccer fields, the parking requirements would not change unless soccer games were also scheduled on weekday evenings when the fields are not used for baseball/softball. Under this scenario the peak parking demand on a the site would increase to 225 spaces. Adding a third full-size soccer field would have a minimal traffic impact as games are currently scheduled on Sundays when street traffic levels are typically lower.
- The estimated peak parking demand was based on the proposed facility programming at Robert Crown Center and the adjoining sports fields during the peak weekday and weekend hours based on program, participation and staffing data provided by the City and Public Library. The analysis also considers the parking demand during the winter (January) when hockey and basketball leagues are underway, and during the Spring/Summer (June) when hockey, baseball and soccer leagues are underway.
- The projected parking demand was tested for reasonableness against published industry-wide parking demand ratios for the major uses on the site.
- The peak parking demand for the redevelopment program is projected to be highest on a Saturday afternoon in Winter due to the added parking demands from the library and new recreation activities (i.e., fitness/dance classes, art classes, running track, etc.) as well as from hockey games that overlap with basketball games.
- The peak parking demand is also projected to be high on weekday evenings in Summer when the preschool/afterschool pick up overlaps with baseball games, hockey games, library visitation, and open gym.
- The projected parking demand on Sundays is anticipated to remain largely the same as under existing conditions since the preschool and library will be closed and the reconfiguration of the soccer fields may result in fewer participants than currently utilize the fields.
- Further, since the reconfiguration of the outdoor sports fields will result in similar levels of participants or fewer, it is not anticipated that the parking demand will increase on the adjoining streets.
- Since there will be no parking-intensive activities occurring in Robert Crown Park during the weekday morning and afternoon time periods that coincide with the Washington Elementary School student arrival and dismissal times, student drop-off/pick-up activity could continue to be accommodated at the east end of the Robert Crown Center parking lot after the redevelopment program is complete.

## Recommendations

Recommended traffic and pedestrian safety improvements are summarized below and shown in **Figure 10**.

- To improve existing traffic operations, minimize the potential for vehicle queues on Main Street to impede traffic movements to and from the Robert Crown Park access drives, reduce the potential for vehicle queues on Dodge Avenue to extend beyond Lee Street, and improve pedestrian safety, the following improvements are recommended at the Main Street/Dodge Avenue intersection. All improvements are recommended by KLOA unless otherwise noted.
  - Install a dedicated right-turn lane on the eastbound approach of Main Street (planned by the City)
  - Extend the left-turn lanes on the eastbound and westbound approaches of Main Street (planned by the City)
  - Install a dedicated right-turn lane on the westbound approach of Main Street
  - Install a dedicated right-turn lane on the southbound approach of Dodge Avenue
  - Extend the traffic signal cycle length by 6 seconds and add right-turn overlap phases
  - Replace the pedestrian signal heads at the Main Street/Dodge Avenue intersection with pedestrian signals that feature countdown timers
- To improve safety along Lee Street, the following improvements are recommended:
  - Install sidewalk along south side of Lee Street along the Robert Crown Park frontage
  - Install “20 MPH Park Zone Speed Limit” signs on Lee Street
  - Install crosswalk on Lee Street at Dewey Avenue with pedestrian crossing warning signs
  - Remark crosswalks at Main St/Dodge Ave intersection with high-visibility markings
- To improve traffic operations and pedestrian safety at the Robert Crown Park’s west access drive, the following improvements are recommended:
  - Restripe Main Street at the west access drive/Dewey Avenue to provide a dedicated left-turn lane (75’ storage lane, 75’ taper) to reduce the potential for left-turning vehicles to block through traffic on Main Street awaiting a gap to make the turn.
  - Install a “Do Not Block Intersection” sign on westbound Main Street at west access drive
  - Design the west access drive with one entrance lane and two exit lanes (right-turn lane and combined through/left-turn lane) to double the stacking capacity on the driveway and prevent possible circulation conflicts within the lot. The through/left-turn lane should be aligned with the southbound lane of Dewey Avenue.
  - Install a stop sign, stop line and crosswalk on the west access drive
- To improve traffic operations and pedestrian safety at the Robert Crown Park’s east access drive, the following improvements are recommended:
  - Restripe Main Street at the east access drive to provide a dedicated left-turn lane (75’ storage lane, 75’ taper) to reduce the potential for left-turning vehicles to block through traffic on Main Street awaiting a gap to make the turn.





**OUTLINE SPECIFICATION**

**ROBERT CROWN COMMUNITY CENTER**  
**OUTLINE SPECIFICATION**  
**Schematic Design Costing Submission**  
**August 2017**

<b>Project Directory</b>	
	<p>Owner: City of Evanston, Illinois</p> <p>Architect – MJMA + WTA</p> <p>Structural – Stearn – Joglekar, Ltd., 223 W Jackson Blvd # 1110, Chicago, IL 60606, USA. 312-461-1800</p> <p>Mechanical Specialty Engineer – Smith and Andersen Consulting Engineering, 4211 Yonge St, North York, ON M2P 2A9 Canada. 416 487-8151</p> <p>Mechanical Engineer of Record – CCJM, 303 E Upper Wacker Dr #303, Chicago, IL 60601, USA. 312-669-0609</p> <p>Electrical Specialty Engineer – Smith and Andersen Consulting Engineering, 4211 Yonge St, North York, ON M2P 2A9 Canada. 416 487-8151</p> <p>Electrical Engineer of Record – CCJM, 303 E Upper Wacker Dr #303, Chicago, IL 60601, USA. 312-669-0609</p> <p>Civil Engineer – Terra Engineering Ltd., 225 W Ohio St, Chicago, IL 60654, USA. 312-467-0123</p> <p>Landscape Architect – CDF, 375 W 1st St, Elmhurst, IL 60126, USA. 630-559-2000</p> <p>Sustainable Design Consultant – Footprint, 4211 Yonge St, North York, ON M2P 2A9 Canada. 416.218.7025</p> <p>Audio-Visual – Arup</p> <p>Acoustical Consultant – Arup</p> <p>Geotechnical Engineer –</p> <p>Commissioning – Grumman / Butkus</p> <p>Traffic Consultant – KLOA</p> <p>Hardware Consultant –</p>
<b>Division 00 – Introductory Information</b>	
	<p>All reports to come:</p> <p>Survey</p> <p>Geotechnical Report</p> <p>Traffic</p> <p>Functional Servicing and Stormwater Management Report</p> <p>Arborist Report</p>
<b>Division 01 – General Requirements</b>	
	<p><b>Sustainable Requirements</b></p> <p>LEED Gold Certification</p> <p>LEED Commissioning</p> <p>LEED Building Envelope Testing</p> <p><b>Allowances</b></p> <p><b>Temporary Tree Protection</b></p>
	<p>The existing Robert Crown Centre will be demolished as part of the project scope, but will remain operational during some of the construction period. The proposed new building will be two storeys, sprinklered, and built of non-combustible construction. The hockey rinks will be contained within a Pre-Engineered structure which will include structure and roof assembly, but skylights and wall assemblies will be excluded from the Pre-Engineered system to be installed by others. The remainin programme areas will be within a traditional Engineered “red-steel” structure. Mechanical equipment will generally be within mechanical rooms, except rooftop units will be used in locations shown and specified by Mechanical. There is a proposed park and sportsfield east of the building that is at the northeast corner of the site.</p>

<b>Division 02 – Existing Conditions, Site Work</b>
<p><b>EXISTING CONDITIONS</b></p> <p><i>Demolition</i> - existing Robert Crown Centre, including removal of associated driveways and parking area.  <i>Tree Removal</i> – Trees located where new building or sports fields are proposed are to be removed.  <i>Tree Protection</i> - Trees at perimeter of site, and cluster of mature trees at SE corner are to be protected in conformance with applicable ordinances.</p> <p><b>SITE WORK</b></p> <p><b>Building Site:</b>  <i>Paving</i> - Asphalt parking lot and driveways (Main st parking lot). HD concrete service driveway including garbage truck access  <i>Curbs and walkways</i> – CIP concrete.  <i>Artificial turf</i>- sports fields. <b>Specification and assembly to be confirmed</b>  <i>Tree Planting</i> – All trees to be field grown quality plant material of caliper shown and with branching configurations and spread characteristics. All trees to be planted in native soil.  <i>Herbaceous Planting and Sodding</i>. <b>Specification and assembly to be confirmed</b>  <i>Exterior site furnishings</i> – 'Ring' bike rack as supplied by Landscapeforms or equivalent  <i>Benches</i>      Engineered fill ? – Refer to Geotechnical Reports      Site Dewatering ? – Refer to Geotechnical Reports</p> <p><b>Site Demolition</b></p>
<b>Division 03 - Concrete</b>
<p><b>Cast in place concrete</b></p> <p><i>Exterior steps, ramps and retaining walls</i> – CIP concrete with architectural finish (concrete retaining wall for East berm, seating steps at east end of sports fields)  <i>Foundation walls, strip and column footings</i> – CIP concrete with architectural finish where exposed to view  <i>Concrete slabs on grade</i>  <i>Concrete curbs/mow strips for synthetic turf attachment</i></p> <p><i>Landscape Concrete (retaining walls, Landscape Walls, Plaza Steps, Concrete Benches)</i></p>
<b>Division 04 - Masonry</b>
<p><b>Concrete Masonry Units CMU Interior Partitions</b>      90, 140 + 190 mm typ. non load-bearing partitions and load bearing where indicated by Structural      Interior architectural feature walls – ground faced concrete block where indicated      Architectural precast concrete wall bases – at base of exterior curtainwall, typical</p> <p><b>Architectural Concrete Masonry Units CMU Interior Partitions</b>      Refer to Interior Finishes Schedule</p>

<b>Division 05 - Metals</b>	
	<p><b>Structural steel framing</b> See Structural</p> <p><b>Steel stairs</b> at Mechanical rooms and exits -metal pan w/concrete, steel rails/guards</p> <p>at Feature stair, steel plate stringer with stainless steel handrails. All welds ground smooth.</p> <p><b>Miscellaneous Metals</b> roof ladders, s/s posts for barrier free door operators, checkerplate surrounds at service doors, anod. Roof ladders – allow for 2</p> <p><b>Wind Bearing Structural Metal Studs</b> Typical exterior cavity wall construction – Wind bearing steel stud framing, 5/8" exterior sheathing</p> <p><b>Metal Fabrications</b>        Loose steel lintels, interior primed, exterior galvanized        Roof ladder, galvanized        Interior lateral supports for masonry        Framing and steel plate jambs for overhead service doors, galvanized        Steel bollards, galvanized        Washroom and Change Room vanity and bench supports, galvanized        Change Table supports, galvanized        Concealed support brackets and overhead framing for interior glazed screens, interior primed or exposed to weather galvanized and as indicated        Overhead door support frames, primed or galvanized as indicated.        Concealed support brackets and framing for overhead folding panel partitions, primed        Concealed support brackets and framing for moveable glazed wall partitions, primed        Concealed support brackets and overhead framing for pivot doors, primed        Overhead framing for suspended fitness equipment in Active Living Studio, primed        Millwork support, primed        HSS support framing at curtain wall wood fins and bench at Library and Community Hall        Metal bases</p> <p><b>Landscape Pipe and Tube Railings</b>        This section includes landscape pipe rail along both sides of the woodland mulch path at the nature play area. Pipe rail shall be 24" tall with two horizontal rails spaced 12" apart vertically.</p>
<b>Division 06 – Wood, Plastics and Composites</b>	
	<p><b>Rough Carpentry</b> Refer to ARCHITECTURAL INTERIOR FINISHES SCHEDULE Pressure treated fire retardant material        – Exterior wood soffit        - Interior wood slat ceiling</p> <p><b>Casework</b> in program rooms - plastic laminate</p> <p><b>Millwork</b> Reception desks (main and library) – solid surfacing, quartzite work surfaces</p>

	<p>W/C and change room vanities, toilet partitions and/or urinal screens – Solid Phenolic, Integral trough sink at Public WC's (Bradley)          Arena changeroom benches – HDPE          Dry changeroom benches – solid surfacing</p> <p><b>Exterior Wood Fence</b>          This section includes split-rail fence around the woodland/ nature play area.          The 3.5' fence is to have two horizontal rails and have a welded wire mesh fabric, such as Omega II Fence Systems, painted black with 2"x3" openings attached to the back of fence, full height, with posts on 8' centers.</p>
<p><b>Division 07 – Thermal and Moisture Protection</b></p>	
	<p><b>Bituminous Foundation Dampproofing and Drainage</b>          At exterior face of foundations walls in contact with soil</p> <p><b>Below-Grade Vapour Barrier</b>          ASTM1745 Class A Perm 0.01          All slab on grade locations</p> <p><b>Air-Vapour Barrier systems</b>          Typical peel and stick systems</p> <p><b>Min R Values</b>          Thermal Performance:          Foundations R15          Walls R22          Roof R30</p> <p><b>Metal Clad Wall Systems</b>  <i>R22 insulation</i>          Formed metal wall panels, custom profiles, LKMe supplied by Muralis Architectural          Supporting sub-girts          6" semi-rigid insulation with thermal clip          Air/vapour barrier membrane          Wall sheathing board          Structural stud framing 203mm or concrete block</p> <p><b>Brick Cavity Wall System</b>  <i>R22 insulation</i>          16" x 4" x 4" ground face architectural concrete masonry units, supplied by Shouldice or Permacon. Assume Diamond White or Charcoal, grout colour to match.          Stainless steel brick ties          6" semi-rigid insulation with thermal clip          Air/vapour barrier membrane          Wall sheathing board          Structural stud framing 203mm or concrete block</p> <p><b>Metal Soffits</b>          Alpollic with fire retardant core or equal          Colour to match existing metal cladding          Fabric weather barrier          Engineered wind bearing metal stud assembly          Compression bracing</p>

	<p><b>Wood Soffits</b>          Tongue and groove solid cedar – Exterior uninsulated          Pressure impregnated fire retardant treated          19mm x137mm T&amp;G cedar          19mm wood nailer @ 400mm o/c          Engineered wind bearing metal stud assembly          Compression bracing</p> <p><b>SBS Modified Bitumen Roofing System</b>          Movement joint where tied into pre-engineered roofing system.          Roof pavers          Roof type R1 – (R30)          Two-Ply SBS Modified Bitumen roof membrane          High SRI Cap Sheet (Soprastar HD GR) -white          Tapered insulation where indicated          75mm Roxul Toprock DD Plus Insulation (adhered)          75mm Polyiso Insulation with (adhered)          Roof Air/Vapour Barrier membrane (self-adhesive type)          Roof sheathing board (mechanically fastened)</p> <p><b>Metal Flashing</b>          At cladding wall system: prepainted galv metal , colour to match wall panel          At Aluminum Framed Glazing: 2mm thick Aluminum, PPG DuranarXL to match window framing</p> <p><b>Fireproofing, Firestopping and Smoke Seals</b>          Fire Resistance Ratings between rooms – walls and floors          Fire exits          1hr FRR steel structure supporting second floor</p> <p><b>Joint Sealants</b></p> <p><b>Expansion Joint Cover Assemblies</b>          For connections between pre-engineered and framed building assemblies</p>
	<b>Division 08 - Openings</b>
	<p><b>Steel Doors and Frames</b>          Exterior locations: typ in non-glazed exterior walls.          Interior locations: Service rooms, Custodial rooms, Storage rooms, Restrooms.</p> <p><b>Fibre Reinforced Panel Doors, Steel Frames</b>          Arena changerooms</p> <p><b>Wood Doors in Aluminum Frames</b>          Offices, Multipurpose rooms, Meeting rooms, Classrooms (Rooms accessible to the public, except washrooms)</p> <p><b>Overhead Coiling Door</b>          Exterior location (resurfacer access door) to be insulated.          Interior locations at resurfacer room to be fire rated, 90 minutes          Interior storage room locations to have perforated slats for ventilation.          All locations motor operated</p>

	<p><b>Automatic Sliding Entrance Doors</b>          Exterior public entry, and lobby vestibule.</p> <p><b>Automatic Door Operator</b>          Building entrances          Grade level exits          Areas of refuge          Interior doors along accessible routes that lead to common elements and amenities          Change room entrances          Accessible public washrooms          Multi-purpose and Activity rooms</p> <p><b>All Glass Partition</b>          Interior:          Silicon butt-jointed glass, flush floor and ceiling channels, 5/8" thk single tempered glass, typical locations, typical locations.          5/8" tempered laminated / 3/4" tempered glass IGU at locations between gymnasium and library</p> <p><b>Aluminum Framed Glazing Systems</b>  <i>(CW1) Curtainwall Type 1 Wall</i> – Kawneer 1600 series – 6" backsections, 2 sided SSG  <i>(CW2) Curtainwall Type 2 Wall</i> – Kawneer 1600 series – 10" backsections, 4 sided SSG          Exterior doors in curtainwall assemblies to be phantom doors</p> <p><b>Sloped Glazing</b>          Kawneer 2000 series skylight.</p> <p><b>Glass and Glazing</b>          Include laminated glass with STC 39          Include bird protection frit on 3<sup>rd</sup> face for all exterior glazing          Exterior and Arena glazing to be double glazed, insulated glass units          Sloped glazing to have laminated glass inside pane, with translucent white PVB interlayer</p>
	<p><b>Division 09 – Finishes</b></p>
	<p>Refer to ARCHITECTURAL INTERIOR FINISHES SCHEDULE (attached)          General Notes:          1. Refer to Finish Schedule and Finish plan for material finish types and scope.          2. Block wall to be filled, primed and painted as required          3. Gypsum Board to be 16mm thick (typical), sanded, primed painted as required          4. Height of all tile finish to be from finished floor to finished ceiling          5. Level 5 drywall finish (typical)          6. Wet areas assume 16mm cement board with heavy duty suspension system – non corrosive fasteners</p> <p><b>Gypsum and Cement Board</b>          All interior walls with GWB to be 16mm high impact          Wet areas to be 16mm cement board with heavy duty suspension system with non corrosive fasteners</p>
	<p><b>Division 10 – Specialties</b></p>
	<p><b>Solid Phenolic Toilet Partitions</b></p> <p><b>Operable Glass Partition</b>          Sliding Folding Continuously hinged with centre stack, no floor track, custom glass</p>

	<p>Modernfold FW-C or equal          Library Entry</p> <p><b>Operable Partition – Paired Panel</b>          Modernfold or equal – Full height marker board finish, no passage door required, manual, STC 50          Large Multipurpose room and Fitness room</p> <p><b>Washroom and Janitor Accessories</b></p> <p><b>Solid Phenolic Lockers</b></p>
<b>Division 11 – Equipment</b>	
	<p><b>Interior Sports Equipment</b>          Gymnasium              (6) retractable basketball backboards/hoops              Volleyball grommets and poles/nets              Batting cage netting – ceiling mounted</p> <p>Ice Arena              Hockey Goals (4)              Rink 1 Scoreboard – ceiling mounted              Figure Skating harness              Ice Resurfacers?</p> <p><b>Exterior Sports Equipment</b>          Baseball              Removable pitchers mound/rubber              Bases              Batter Backstop and fencing              Player benches</p> <p>Soccer              (6) mobile soccer goals              Overkick netting at north and south ends (6)</p> <p>Football              (2) fieldgoal poles              (4) endzone pilons</p>
<b>Division 12 – Furnishings</b>	
	<p><b>Roller Window Shades</b></p> <p><b>Entrance Floor Grilles</b></p> <p><b>Motorized Drop-Down Divider Curtain</b>          Gymfold SE by Moderco</p> <p><b>Fixed Bench Seating</b>          Moulded plastic bench seating to be installed directly on 16" high cast-in-place or precast concrete steps.          "G3 bench style seat" by Daplast</p> <p><b>Telescoping Seating</b>          Motor operated Telescoping bleacher system, 16" riser per row, 36" row spacing. "Maxam+ Telescopic Platform" with moulded</p>



	<p>plastic shell seats "A2 backless shell seat" by Daplast</p> <p><b>Site Furnishings</b>          This section includes fixed benches, waste receptacles, landscape planters and bike racks.          Refer to Architect's specifications for site signage including informational kiosks.          Benches will be hi-end product, such as Landscape Forms "Harpo" bench with powder-coated aluminum frames and IPE wood seat and back. Quantity allowance = 20          Waste receptacles shall match bench selection. Quantity allowance = 15          Bike racks to be hi-end product, such as Landscape Forms "Bicilinea", 238" length. Quantity allowance = 3.          Planters shall be Form and Fiber Cor-Ten Planters from the Essentials Collection, Style ES_30C. Quantity allowance = 4.</p>
	<b>Division 13 – Special Construction</b>
	<p><b>Ice-Rink Arena Board System</b>          Non-removable HDPE arena boards, and additional HDPE panels. Clear boards where required for sled hockey.          Player's benches, timekeeper's counter, penalty box benches and coach's benches. Player's and penalty boxes to be convertible for sledge hockey.          Swing gates and removable board sections          Glazed shields          Netting at radii and ends          Based on Athletica SSU PRO XL system, or equivalent</p> <p><b>Ice-Rink Slab</b>          Sand base installed in 2 lifts containing heating piping (piping by div 15)          Min 50thk Highload60 insulation          Slip Sheet          Cast-in-place concrete slab containing rink piping (piping by div 15), finished to FF45, FL35, level within 3mm/3000          Contractor to be prequalified and to have completed a minimum of 10 rinks in the past 5 years similar to those specified.          Ice-Rink Refrigeration System Specified under div 15</p> <p><b>Sound Attenuated Floating Floor System</b>          Geniemat FF70 floating floor system, below 6"thk reinforced floating concrete topping slab.</p> <p><b>Engineered Steel Building System</b>          Steel building system enclosing Arenas and Preschool. System to include steel framing and roof system. Roof system to be 'MR-24 Roof System' by Butler Manufacturing Company or equivalent.</p>
	<b>Division 14 – Conveying Equipment</b>
	<p><b>Passenger Elevator</b>          4500lb floor rating to be used as service elevator when required. Cab min 1525x2030 clear. Standard finishes, all interior surfaces, doors and jambs to be stainless steel. Vandal Resistant controls. Full height mirror rear wall of cab.</p>
	<b>Division 22 – Plumbing</b>
	<p><b>Water Main</b></p> <p><b>Sanitary Sewers</b></p>
	<b>Division 26 – Electrical</b>
	<p><b>Exterior Athletic Lighting</b></p>
	<b>Division 31 – Earthwork</b>

	<p><b>Site Clearing</b></p> <p><b>Earthwork</b></p> <p><b>Finish Gradings for Synthetic Grass Surfacing</b></p> <p><b>Excavating Backfilling and Compacting for Utilities</b></p> <p><b>Erosion and Sedimentation Control</b></p> <p><b>Bioretention Soil</b>          This section includes bioretention soil installed over separation fabric and open-graded stone base at all bioretention areas shown on the drawings and details. Section also includes soil amendments and stone infiltration trench.</p> <p><b>Athletic Field Earthwork</b>          Conformance Survey of prepared sub-grade          Geo-technical and Compaction testing for prepared sub-grade          Proof-roll of prepared sub-grade</p>
	<b>Division 32 – Exterior Improvements</b>
	<p><b>Hot Mix Asphalt Paving</b></p> <p><b>Concrete Paving</b>          Pedestrian Walkways, Vehicular paving for drive approaches and concrete curbs</p> <p><b>Crushed Stone Surfacing (with steel edge)</b>          Exterior reading room</p> <p><b>Porous Unit Paving</b>          This section includes porous unit paving for the main parking lot and the service drive.          Unit pavers shall be Unilock Eco Priora, River color or equivalent</p> <p><b>Pavement Markings</b></p> <p><b>Playground Protective Surfacing</b>          This summary includes playground surfacing for the nature play area.          Surfacing shall be Engineered Wood Fibar.</p> <p><b>Planting Irrigation</b>          Irrigation system shall be a complete, fully automated system similar to Rain Bird with all controllers, valves, wiring, pump if needed and RPZ</p> <p><b>Exterior Plantings</b>          This section includes deciduous and evergreen trees and shrubs, woody and herbaceous groundcovers, and mulch path.          Deciduous trees shall be planted for shade in parking and pedestrian areas as shown on the drawings. The average size of deciduous trees shall be 3-inch caliper. Quantity allowance = 125.          Woody shrubs. The average size shall be 5 gal. Quantity allowance = 300.          Herbaceous groundcovers shall be densely planted in all planting areas including bioretention areas. For now all areas shown as landscape beds shall be assumed to have this planting approach unless otherwise specified. The average size of these plantings will be a 1 gal. pot planted on 18-inch spacing. Top dress all landscape beds with 2" of partially decomposed leaf compost after planting.          Restored woodland vegetation shall be 2.5" plugs planted on 12-inch spacing.          The woodland mulch path shall be premium, shredded hardwood bark mulch placed to a depth of 6". Mulch to be placed on top of existing grade, no excavation required due to critical root zones. No edging required, mulch edge with taper to grade</p>

	<p>naturally.</p> <p><b>Turf Grass</b>          Irrigated turf areas shall be seeded with Barenbrug Turf Blue HGT.          Turf landforms shall be seeded with "no mow" Titan Turf-Type Tall Fescue Mixture.</p> <p><b>Soil Cells</b>          This section includes prefab soil cell units in the parking lot and gravel courtyard in order to provide a sufficient growing environment for trees under a hardscaped/ paved condition or where there is insufficient landscape bed area to sustain a viable tree.</p> <p><b>Synthetic Turf Surfacing</b>          3rd Generation Synthetic Turf with infill for sports usage          Turf Nailer attachment to concrete curbs          Inlays and tufting of the field markings          Shock Pad under the turf (as desired)</p>
	<p><b>Division 33 – Site Utilities</b></p>
	<p><b>Water Service</b></p> <p><b>Storm Sewers and Drainage</b></p> <p><b>Synthetic Turf Base Construction</b>          Finish aggregate for the field drainage          Base aggregate for the field drainage          Course aggregate for sub-drainage trenches          HDPE sub-drainage piping          Filter Fabric          Conformance Survey of aggregate before pad/turf installation</p>

**MATERIAL**

**DIVISION**

**INDEX**

Architectural Concrete Masonry Units	04 22 23
Architectural Woodwork Interior - HDPE	06 40 00
Architectural Woodwork Interior - Plastic Laminate	06 40 00
Solid Phenolic Panel - SPH	06 40 00
Architectural Woodwork Interior - Solid Surface	06 40 00
Architectural Woodwork Interior - Built In Tackable Surface	06 40 00
Service Room Traffic Coating	07 18 16
Glass and Glazing Film	08 80 00
Safety Floor	09 65 18
Tile - Floor Tile (TL0x series)	09 31 00
Tile - Wall Tile (TL1x series)	09 31 00
Acoustic Tile Ceiling	09 51 23
Metal Panel Ceiling	09 54 50
Wood Athletic Flooring	09 64 66
Premanufactured Bases	09 65 13
Static Dissipative Floor	09 65 36
Solid Vinyl Tile	09 65 17
Resilient Athletic Flooring	09 65 66
Terrazzo	09 66 23
Epoxy Floor Coatings	09 67 10
Carpet	09 68 00
Acoustic Wall Panels	09 77 13
Painting	09 91 00
Visual Display Surfaces	10 11 00
Solid Phenolic Lockers	10 51 26
Solid Phenolic Partitions	10 21 13
Roller Window Shades	12 24 13

**Architectural Concrete Masonry Units**

**04 22 23**

Abbrev.	Specification	Contact	Notes	Sample
ACMU	<p>Architectural concrete masonry units            Size: 90mmx90mmx390            140mmx90mmx390mm            190mmx90mmx390mm</p> <p>Texture: Tapestry-smooth polished face texture with no bevel</p> <p>Profile: Buffed (no bevel)</p> <p>Acceptable Products:            Shouldice 'Architectural Stone' Colour: Crystal White  <i>or</i>            Permacon Group Inc 'Noble Architectural Block' Carrera White (Final Colour later chosen by consultant)</p> <p>Pattern: Stack Bond</p>	<p>Shouldice            Don Mitchell  <a href="mailto:donrmitchell@sympatico.ca">donrmitchell@sympatico.ca</a>  <i>or</i>            Permacon" Bruce Wilson            905-317-6067  <a href="mailto:bwilson@permacon.ca">bwilson@permacon.ca</a></p>	<p>Interior Block walls in public corridor areas – see A800 series plans for extent (refer to exterior elevations for extent on exterior envelope)</p>	

## INTERIOR FINISHES SCHEDULE

August 11<sup>th</sup>, 2017

Issued for SD Costing

**Architectural Woodwork Interior - Plastic Laminate****06 40 00**

Abbrev.	Specification	Contact	Notes	Sample
PLAM1	Pionite – Angel White Finish Suede	Tracy Agius <Tracy.Agius@wanderosa.com>	General Back of house millwork cabinets, kitchenettes	
PLAM2	Abet Laminati Polaris Series Colour TBD	Leila Callovini ABET LAMINATI <u>5195 Timberlea Bld</u> <u>Mississauga, ON</u> <u>L4W 2S6</u> Cust. Serv/Orders- 1.800.228.2238 Direct- 416.720.9162 <u>ca.abetlaminati.co</u> <u>m</u>	Front of house – feature millwork	

**Solid Phenolic Panel - SPH**

**06 40 00**

Abbreviation	Specification	Contact	Notes	Sample
Solid Phenolic Panel	25mm Solid Phenolic Panel Gentas or Fundermax Colour: Charcoal		Wall Signage Panel in Arena Area	

INTERIOR FINISHES SCHEDULE

August 11<sup>th</sup>, 2017

Issued for SD Costing

**Architectural Woodwork Interior – Solid Surface**

**06 40 00**

Abbrev.	Specification	Contact	Notes	Sample
SSF1	Dupont – Corian – Glacier White 13mm and 19mm thick for counters and side panels. 6mm thick for integral backsplashes and wall cladding		Millwork, Benches in Rec/Fitness Changerooms, Grooming stations,	
SSF2	Caesar Stone Concrete 2003 20mm  Ceasar Stone		Reception Counter Tops, Kitchenettes	



**Architectural Woodwork Interior – HDPE**

**06 40 00**

Abbrev.	Specification	Contact	Notes	Sample
HDPE1	19mm HDPE panels - White		Benches in Arena Viewing Change Rooms	

## INTERIOR FINISHES SCHEDULE

August 11<sup>th</sup>, 2017

Issued for SD Costing

**Architectural Woodwork Interior – Built In Tackable Surface****06 40 00**

Abbrev.	Specification	Contact	Notes	Sample
TKS1	Forbo – Bulletin Board – 6mm Colour: 2202– black Corner/edge trim Trim to be Schluter Jolly – Brushed Anodized Aluminum – Satin Clear – Size to suit thickness of tile	Christie White <a href="mailto:Christie.white@forbo.com">Christie.white@forbo.com</a> 416-661-2351 x233; 416-520-2127	Millwork detail finish at Front Desk, display walls	
TKS2	Forbo – Bulletin Board – 6mm Colour: 2187 – light beige Corner/Edge Trim to be Schluter Jolly – Brushed Anodized Aluminum – Satin Clear – Size to suit thickness of tile	Christie White <a href="mailto:Christie.white@forbo.com">Christie.white@forbo.com</a> 416-661-2351 x233; 416-520-2127	Millwork detail finish at Front Desk, display walls	

INTERIOR FINISHES SCHEDULE

August 11<sup>th</sup>, 2017

Issued for SD Costing

**Service Room Traffic Coating**

**07 18 16**

Abbrev.	Specification	Contact	Notes	Sample
SRTC	Service Room Traffic Coating Sikafloor Resoclad MRW Type II = Sikalastic Duochem 390 membrane + Sikafloor 6001 topcoat in one system Two grey colours to choose from – TBD  Thickness 1mm  Or similar	Nellie Vila-Legare M 416-889-7003 vila.nehal@ca.sika.com	Mechanical Upper Levels, Workshop, Zamboni areas	

**Glass and Glazing Film**

**08 80 00**

Abbrev.	Specification	Contact	Notes	Sample
GLBP1	<p>MagiCoat Back Painted Glass - Minimum 6 mm thick tempered glass sandblasted (surface1) low iron Epoxy two component system            Colour: PTa</p> <p>Extruded aluminum, clear anodized, channel shape for all exposed edges of back painted glass</p>	<p>Colin Sless            Imagicglass  <a href="mailto:colin@imagicglass.com">colin@imagicglass.com</a>            905-695-3104</p>	<p>White Back Painted Glass            Reception Area and Book Check Area</p>	
GLBP2	<p>MagiCoat Back Painted Glass - Minimum 6 mm thick tempered glass sandblasted (surface1) low iron Epoxy two component system            Colour: to match PTs</p> <p>Extruded aluminum, clear anodized, channel shape for all exposed edges of back painted glass</p>	<p>Colin Sless            Imagicglass  <a href="mailto:colin@imagicglass.com">colin@imagicglass.com</a>            905-695-3104</p>	<p>Charcaol Back Painted Glass</p>	

**Interior Glass Partitions and Doors**

**08 80 00**

**Aluminum Framed Glazing Systems**

**08 44 00**

Abbrev.	Specification	Contact	Notes	Sample
SF1	Interior Aluminum Door & Storefront Glazing System  Alumicor 3400 Series  Finish Duranar finish from standard colour range  Interior Glazing 16mm butt joint laminated glass  Interior Doors 44mm solid wood door painted PT1		Interior Glass Screen – Admin Areas	
SF2	Butt Joint Glazing in Aluminum Glazing Shoe  CRL SR4SSA34SL 16mm and 19mm laminated glass 4" high Clear anodized aluminum  Header Rail CRL NH3  For 13mm lamninated glass Shoe CRL WU3SASL w Gasket RG12100 Header CRL UCSA3812SL		Interior Glass Screen – at Fitness, Library Childcare	

INTERIOR FINISHES SCHEDULE

August 11<sup>th</sup>, 2017

Issued for SD Costing

SF3	<p>Butt Joint IGU</p> <p>Or Alumaticore Univent 1350</p> <p>Provide Laminated glass layer for Library/Gymnasium Screen</p>		Glass Screens at Arena and Library/Gymnasium	
SF4	<p>Two options to be explored with regards to wind loads and maximum spans (yes interior has wind loads) :</p> <ol style="list-style-type: none"> <li>1. Therma Wall 2600 SSG</li> <li>2. Versa Wall Midline 2200 SSG</li> </ol> <p>Option 2 is preferred.</p>		Interior Curtain Wall	

**Safety floor**

**09 65 18**

Abbrev.	Specification	Contact	Notes	Sample
SFT1	Safety floor – Sheet good Altro reliance 225 Colour Storm Heat welded seams		Floor in Concession Area	

**Tile - Floor Tile (TL0x series)**

**09 31 00**

Abbrev.	Specification	Contact	Notes	Sample
TL01	American Olean – Unglazed Porcelain Mosaic – 50mmx50mm Colour-Speckled Charcoal ST 12592– Finish: Standard Corner/Edge Trim to be Schluter Jolly – Brushed Anodized Aluminum – Satin Clear – Size to suit thickness of tile	Warren Booth 416-568-7255 <a href="mailto:Warren.booth@daltile.com">Warren.booth@daltile.com</a>	Public washrooms	
TL02	American Olean – Unglazed Porcelain Mosaic – Speckled Charcoal ST 12592– – Finish: Abrasive Corner/Edge Trim to be Schluter Jolly – Brushed Anodized Aluminum – Satin Clear – Size to suit thickness of tile	Warren Booth 416-568-7255 <a href="mailto:Warren.booth@daltile.com">Warren.booth@daltile.com</a>	Floor Tile Change Room Floors – showers Cove bases	
TL03	American Olean – Unglazed Porcelain Mosaic – Colour- Speckled Charcoal ST 12592– Corner/Edge Trim to be Schluter Jolly – Brushed Anodized Aluminum – Satin Clear – Size to suit thickness of tile	Warren Booth 416-568-7255 <a href="mailto:Warren.booth@daltile.com">Warren.booth@daltile.com</a>	Shower Floors in Arena	



**Tile - Wall Tile (TL1x series)**

**09 31 00**

Abbrev.	Specification	Contact	Notes	Sample
TL10	<p>Stone Tile: Progetto            Ceramiche: Bianco gl            Size 100mmx400mm            Or Centura Urban White            100mmx400mm</p> <p>Finish:            80% matte            20% gloss            Pattern: Horizontal            1/3 Offset Bond            Corner Trim to be            Schluter JOLLY –            Brushed Anodized            Aluminum – Satin Clear            – Size to suit thickness of            tile</p>	<p>Debra Rubin            Architectural Sales            Stone-Tile            International            416-515-9000 ext            245            Cell: 416-888-3322  <a href="mailto:debrar@stone-tile.com">debrar@stone-tile.com</a>  <a href="http://www.stone-tile.com">www.stone-tile.com</a></p>	Shower Areas and change rooms	
TL11	<p>Ceramic Unglazed            Penny rounds            25mmx25mm mosaic            Colour- White            Finish: Regular            Refer to Specification for            Edge and corner trims</p>	<p>Warren Booth            416-568-7255  <a href="mailto:Warren.booth@daltile.com">Warren.booth@daltile.com</a></p>	Backsplashes	
TL12	<p>Large Format Tile            Laminam collection            Colour: Nero            Size: 1Mx3M 3mm thick            Maximum size</p>	<p>Debra Rubin            Architectural Sales            Stone-Tile            International            416-515-9000 ext            245            Cell: 416-888-3322  <a href="mailto:debrar@stone-tile.com">debrar@stone-tile.com</a>  <a href="http://www.stone-tile.com">www.stone-tile.com</a></p>		

**Acoustic Tile Ceiling**

**09 51 23**

Abbrev.	Specification	Contact	Notes	Sample
ACT2	Hunter Douglas "Techstyle E" Ceiling Lay In Size:TBD (Imperial Sizes Please – Trims:TBC  <b>Suspension System:</b> Armstrong Prelude 15/16" Colour: WH	Jadranka Madarin Sound Solutions	Back of House areas- Admin Areas	
ACT1	Hunter Douglas "Techstyle E" Ceiling Classic Clipped Size:TBD (Imperial Sizes Please – Trims:TBC <b>Suspension System:</b> Armstrong Prelude XL 15/16"Standard Colour WH Provide Prelude XL AL 15/16" in Humid Areas Colour: WA	Jadranka Madarin Sound Solutions	Change rooms, Public Corridors	

**Wood Athletic Flooring**

**09 64 66**

Abbrev.	Specification	Contact	Notes	Sample
WAF1	Robbin's Bio Channel SB 44mm  OR  Connor - Focus  Vented base: Johnsonite (no alternates) – Colour Black  Custom vented base where indicated  Finish: -2 sealer coats water based urethane, painted game lines, end lettering and Logos, -2 finish coats of water based urethane	Joe Wilson Gym-Con Ltd. 33 Alliance Blvd., Unit #11 Barrie, ON L4M 5K2 Tel: (705) 728-2222 Ext. 107 Fax: (705) 728- 2266 Cell: (289) 259- 1381  OR  George Fiotakis WestPoint commercial athletic dance FLOORING www.westpointsport.c om T: 905-726-3500 (ext. 210) TF: 866-959-9300 F: 905-726-3506	Gym Floor	

**Premanufactured Bases**

**09 65 13**

Abbrev.	Specification	Contact	Notes	Sample
RB1	<p>ROPPE Pinnacle Series Base (Consultants Approval)</p> <p>Carpet Tile and Resilient floor conditions</p> <p>Other Acceptable Manufacturers: Johnsonite and FORBO</p>	<p>Liz Livingston Architectural &amp; Design Consultant ARIDO, IDC.</p> <p>T: 416-785-5165 C: 416-434-8626 F: 416-783-0636 E: <a href="mailto:elivingston@centura.ca">elivingston@centura.ca</a> <a href="http://www.centura.ca">www.centura.ca</a></p>	White Base-Typical	
ALUM BASE	<p>100mm high profile Anodized Aluminum - Clear</p> <p>Site fabricated internal and external corners. Edges Ground smooth</p> <p>Products: Profilitec BAS100</p> <p>Or Carter metal fabricators</p>	<p>Debra Rubin Stone-Tile 416-515-9000 ext 245 Cell: 416-888-3322 <a href="mailto:debrar@stone-tile.com">debrar@stone-tile.com</a> <a href="http://www.stone-tile.com">www.stone-tile.com</a></p>	Lobby areas-Public Corridors	

**Static Dissipative Floor**

**09 65 36**

Abbrev.	Specification	Contact	Sample	Sample
SDF1	Static Dissipative Floor – Armstrong – Static Dissipative Tile – 51953 'Pearl White' or 'Fossil Grey'	Janet Sayers Product Consultant Division 9 - A Shnier Company <a href="mailto:Jsayers@gesco.ca">Jsayers@gesco.ca</a> Cell 647-282-5482	Main IT Room	

**Solid Vinyl Tile**

**09 65 17**

Abbrev.	Specification	Contact	Notes	Sample
SVT1	Texas Granite	Centura	Adminstration and Multipurpose room areas , Childcare Area	

**Resilient Athletic Flooring**

**09 65 66**

Abbrev.	Specification	Contact	Notes	Sample
RAF1 Fluid Applied	GymCon Pulastics Classic 110 Thickness 11mm  Colour: Non Standard Charcoal Game Lines Bright White	Joe Wilson Gym-Con Ltd. 33 Alliance Blvd., Unit #11 Barrie, ON L4M 5K2 Tel: (705) 728-2222 Ext. 107 Fax: (705) 728-2266 Cell: (289) 259-1381	Running Track (Fluid Applied)	
RAF2	Mondo Armour 18mm thick system Colour-later Chosen by Consultant	Joe Wilson Gym-Con Ltd. 33 Alliance Blvd., Unit #11 Barrie, ON L4M 5K2 Tel: (705) 728-2222 Ext. 107 Fax: (705) 728-2266 Cell: (289) 259-1381	Fitness Room	
RAF3	Mondo-Sport Impact 10mm thick 900mmx900mm Square Edge Tile Custom Colour: Colour TBD	Joe Wilson Gym-Con Ltd. 33 Alliance Blvd., Unit #11 Barrie, ON L4M 5K2 Tel: (705) 728-2222 Ext. 107 Fax: (705) 728-2266 Cell: (289) 259-1381	Skate Floor in Arena Changerooms, Arena Corridors, Player & Penalty Boxes, Arena 1 Warm-side Viewing Area	

INTERIOR FINISHES SCHEDULE

August 11<sup>th</sup>, 2017

Issued for SD Costing

RAF4	Not used			
RAF5	Gym Con beehive Matt – loose laid – butt joint Provide transition threshold ramps to match system Colour: Black Full size tiles	<i>Joe Wilson</i> Gym-Con Ltd. 33 Alliance Blvd., Unit #11 Barrie, ON L4M 5K2 Tel: (705) 728-2222 Ext. 107 Fax: (705) 728- 2266 Cell: (289) 259- 1381	Loose Laid Skate Matt at penalty boxes –	



## INTERIOR FINISHES SCHEDULE

August 11<sup>th</sup>, 2017

Issued for SD Costing

**Terrazzo****09 67 10**

Abbrev.	Specification	Contact	Notes	Sample
TRZ1	<p>Epoxy Matrix Terrazzo EMBE Morricite Epoxy Terrazzo by Technical Barrier Systems Inc. or Mondeco Seamless Epoxy Terrazzo by Flowcrete or Duochem 9017 Epoxy Terrazzo by Duochem Inc. Or 9.5mm Sikafloor Terrazzo</p> <p>Colour: Control sample D200032 MJMA - Sika</p>	<p>Nellie Vila- Legare Architectural Sales Representative Flooring Division Vila.nehal@ca.sika. com</p> <p>Or</p> <p>Dana Gabriellow Stonhard (416) 605 – 0069 <a href="http://www.stonhard.com">www.stonhard.com</a></p>	<p>Public Lobby and Corridor Precast Epoxy Stair</p>	

**Carpet**

**09 68 00**

Abbrev.	Specification	Contact	Notes	Sample
CPT1	Woven Vinyl Tile LOOM Carpet by Centura Tile  Series  Opt 1: Knit ColourFT-2212 or FT 2209 Pattern: Play# 7 Size: 100x50cm  Or Equivalent from Bolon	<b>Liz Livingston,</b> ARIDO, IDC Architectural & Design Consultant  950 Lawrence Avenue West, Toronto, Ontario.  T 416-785-5165 C 416-434-8626 <a href="http://www.centura.ca">www.centura.ca</a>  <u>Bolon</u> Jo Anne Crompton Design 2 Spec Inc 104 Burnhamthorpe Road, Lower Level Toronto, On M9A 1H4 T 647 435 1074	Library	

**Acoustic Wall Panels**

**09 77 13**

Abbrev.	Specification	Contact	Notes	Sample
AWP1	Acoustic Wall Panels Avanti Panels Max panel Size:48"x120" Thickness: 1 1/8" Type: Hard Surface wall Panel by Avanti Mounting Type: Wall mounted - cleats with leveling angle and adhesive as per manufacturers recommendations Edge: Square 90degree edge  Fabric: Series: Billiard Panel (DesignTex) Colour: Ink	Sound Solution Jadranka Madarin	Library in Study Rooms	

**Metal Panel Ceiling (Interior)**

**09 54 50**

Abbrev.	Specification	Contact	Notes	Sample
CMP1	ALPRO – C Panel .032” – Aluminum Smooth Regular White PDR20100  3000mm panel lengths  Perimeter Trims- Extruded Aluminum 100mm – Gordon Contura  Face attached to Concealed Suspension System  Perforated  Insulation Owens Corning Select Sound Black Acoustic Blanket		Aluminum Perforated Acoustic Ceiling Gymnasium	

**Painting**

**09 91 00**

Abbrev.	Specification	Contact	Notes	Sample
PT1	Benjamin Moore Colour: Chantilly Lace #2121-70		Field Colour: White	
PT2	Benjamin Moore Colour: TBD		Colour: Charcoal	Upper Ceiling
PT3	Benjamin Moore Colour: TBD			

**Visual Display Surfaces**

**10 11 00**

Abbrev.	Specification	Contact	Notes	Sample
VDS1	4 meters x1.5 meters Frame: VIP Aluminum Frame and Extruded Aluminum Clip System Surface Type: Forbo Tackable Surface (Colour TBD) Mounting: surface mounted	ASP – Architectural School Products	Tackable Frames Display Board in Public Lobby Qty 3, Each MPR Room	

**Solid Phenolic Lockers**

**10 51 13**

Abbreviation	Specification	Contact	Notes	Sample
LOCKER	<p>Prospec UCS   INC- Solid Phenolic – Marathon Lockers</p> <p>Or</p> <p>Locker Doors 13mm solid phenolic panels. Doors to have 6mm radius corners and polished edges. Provide trims, end panels and closure pieces as required 13mm solid phenolic</p> <p>Hardware: Hinges shall be constructed of 304 stainless steel- three for full height unit two for double tier units. Hinges shall be held in place with a 1/4-20 stainless machine screw into predrilled hole, tapped and reinforced as required</p> <p>Locking system: TBD</p> <p>Interior Hooks- Provide stainless steel limit arm opening no more than 90 degrees</p> <p>Identification Plates:</p> <p>Numbering sequence provided by others</p> <p>Ventilation Provide 9.5mm slot back of top and intermediate shelves and one at front of bottom shelf</p> <p>: Height 60"</p>	<p>Bill Roper Prospec US Sales Manager <a href="mailto:bill.roper@prospec.us.com">bill.roper@prospec.us.com</a> 636-236-2909 Cell 239-243-0778 US Office \</p> <p>Or Bobrick</p>		

INTERIOR FINISHES SCHEDULE

August 11<sup>th</sup>, 2017

Issued for SD Costing

	<p>Width: 18" Depth 18" 50% double tiered 50% single</p> <p>All solid phenolic to be White (if pure white is not available as standard then assume custom white) to Consultant's approval</p> <p>Base Type: Plinth by other (Refer to Drawings)</p>			
--	---	--	--	--



**Solid Phenolic Partitions**

**10 21 13**

Abbrev.	Specification	Contact	Notes	Sample
	Prospec Marathon Connect Series -Floor Mounted Overhead braced - Safety Latch -Adjustable Aluminum Legs Frame: Aluminum Extrusions Fittings: Continuous Aluminum headrail Wall Channel: Continuous extruded wall channel Door Fittings: 2No sping loaded soft closing hinges Door Latch: aluminum with indicator and emergency release to exterior, rubber buffer sited within lock receiver Aluminum Finish: Satin Clear anodized to 25 microns 2 coat hooks per cubicle Pilaster Doors Partition and End Panels: 12mm Solid Phenolic Edge Treatment” bull nosed with radiused corners Solid Phenolic colour: 0085 White  Shower Curtains: Super Bio Stat Shower Curtains by Clickese Privacy System Colour: Transluscent Style: Type 2	ATS Sales	Change Cubicles and wash room cubicles in change/pool area and public washrooms	

**Roller Window Shades**

**12 24 13**

Abbrev.	Specification	Contact	Notes	Sample
RWS1	<p>Hunter Douglas            RB500 Series            Motorized</p> <p>Housing Trim: Aluminum            Non Standard Colour to            match adjacent Mullions</p> <p>Motors: Non corrosive            metal gears to suit            weight of blind and            speed            Between window framing            – type of motor V - TBD</p> <p>Room Darkening Side            and Bottom Channel –            custom colour to match            mullion colour, snap on            concealed fasteners</p> <p>Fabric 0%- 5%            Openness PVC            fibreglass core (mesh            type)- Colour and            openness to be            determined later by            consultant</p> <p>Size: (max 96” W – 3030            yd L)assume maximum            sizes – mullion to            mullion-floor to ceiling</p> <p>Hembar Pockets            Rectangle Aluminum            allow 6063 – Colour to            match adjacent window            framing</p>	<p>Jack Balmonte            Hunter Douglas            Contract/ 12250            Parkway Centre Dr.            / Poway, CA            92064/ Phone: 800-            727-8953 Fax: 800-            205-9819/ Website:  <a href="http://www.hunterdouglascontract.com">www.hunterdouglas            contract.com</a>,</p>	<p>Arena</p>	
RWS2	<p>Hunter Douglas            RB500 Series            Motorized</p> <p>Size: (max 96” W – 3030</p>	<p>Hunter Douglas            Contract/ 12250            Parkway Centre Dr.            / Poway, CA            92064/ Phone: 800-</p>	<p>Multipurpose,            Library,            Gymnasium,            Childcare</p>	

INTERIOR FINISHES SCHEDULE

August 11<sup>th</sup>, 2017

Issued for SD Costing

	<p>yd L)assume maximum sizes – mullion to mullion-floor to ceiling</p> <p>Housing: Extruded Aluminum – Custom Colour to match adjacent mullions or window frame</p> <p>Fabric 0%- 5% Openness PVC fibreglass- Colour and openness to be determined later by consultant – Interior Grade fabric</p>	<p>727-8953 Fax: 800-205-9819/ Website: <a href="http://www.hunterdouglascontract.com">www.hunterdouglascontract.com</a>,</p>		
--	--	---	--	--



**CIVIL**



## **CIVIL ENGINEERING NARRATIVE: DEMOLITION, STORMWATER MANAGEMENT, AND PROPOSED UTILITIES**

-Note: Reference TERRA Engineering topographic survey dated 8/4/17 for additional information

### **I. Existing Site Conditions:**

The referenced project is located at 1701 Main Street in the City of Evanston, and is contained by Main St. to the south, Dodge Ave. to the West, and Lee St. to the north. The property is roughly  $\pm 16.13$  acres in size, and is mostly comprised of athletic fields and open space. Existing site appurtenances include a two-story brick building and a paved asphalt parking lot with two access driveways along Main Street. The site also contains multi-use athletic fields to the north of the existing building, two baseball diamonds on the west half of the property, and four tennis courts at the northwest corner of the property that are intended to remain undisturbed. Per the existing topography of the property, the southeast corner of the site is approximately  $\pm 7$  feet higher than the northwest corner.

#### *Onsite Utilities*

Most of existing utilities onsite are located within the existing building and parking lot area and connect into the right-of-way within Main St. Existing utilities in the existing building area include sewer, low voltage, electrical, and water utility connections. There are various water and storm sewer appurtenances located in the spectator areas of the tennis courts and both baseball fields. Buried electrical and low voltage services are assumed to route throughout the property to service the various field lighting poles and buildings onsite. Per Com Ed atlas maps obtained by TERRA through a Julie Design Stage Locate, there are two existing Com Ed meters onsite, one for the existing building and one at the northwest corner of the site.

A City of Evanston deep storm sewer currently is routed through the site. In addition, a 7'-diameter air release vent that serves this deep sewer is located approximately  $\pm 84$  feet west of the western most access drive along Main Street. The deep storm sewer was located based on record drawings obtained from the City of Evanston. See TERRA topographic survey of the project for more details.

#### *Utilities in the Evanston Right of Way*

Main St., adjacent to the south side of the property, has underground City of Evanston combined sewer and 12" potable water main, Nicor gas main, and underground ATT low voltage that connects the existing building to Dewey Ave. The City of Evanston deep sewer also runs through part of Main St. adjacent to the project.

Dodge Ave, adjacent to the west side of the property, has City of Evanston combined sewer, storm sewer, and 6" potable water main, Nicor gas main, and underground Com Ed electrical duct bank. The City of Evanston storm sewer in Dodge Ave. heads south and ultimately outfalls to Metropolitan Water Reclamation District of Greater Chicago (MWRDGC) sewer.

Lee St, adjacent to the north side of the property, has City of Evanston combined sewer, storm sewer, and 6" potable water main, Nicor gas main, and underground Com Ed electric feed routed from the northwest corner of the site under Lee St. and connects to the utility poles in the alley on the north side of Lee St.

### **II. Site Demolition:**

#### *Removal of Existing Improvements*

With the exception of the tennis courts at the northwest corner of the site, all above grade paving improvements are to be removed from the site. Select trees onsite will be saved and protected during construction, reference landscape documents for more details. All existing buildings and their associated foundations and appurtenances shall be removed from the site. Existing turf grass and other landscape areas shall be cleared and grubbed and prepared for installation of the new site improvements. Reference the landscape and architect site plans for more details of proposed improvements.

#### *Removal of Existing Utilities*

All existing underground and above ground utilities will be removed and/or abandoned onsite per City of Evanston and the respective utility company requirements. This includes all services to the existing building and parking lot at the southeast corner of the site which include underground telecom, Com Ed, water, and sewer.

Combined MH-2914 (reference topographic survey) located at the west driveway exit is the primary outlet structure for the sanitary and storm sewers which currently serve the existing building and parking lot. Each inlet pipe at MH-2914 shall be removed and plugged per

MWRD specifications, and all associated piping and structures located upstream, shall be removed during demolition as necessary. MH-2914 shall be abandoned in place to avoid performing work within the public right-of-way. However, based on the intended design and layout of the proposed stormwater management facilities, it may be re-purposed as an outfall sewer connection for sanitary sewer if feasible.

The water service tap which services the existing building is connected to the 12" watermain located within Main St. The service tap is currently in an impractical location to serve the proposed building, and is therefore recommended to be terminated and removed per City of Evanston requirements. As previously mentioned, there are two additional water services located within the spectator areas of the existing baseball fields. If these water services will not be used in the design of the proposed site, they shall also be terminated and removed as necessary per City of Evanston requirements.

### III. Proposed Site Conditions:

The schematic stormwater calculations are based on the proposed site layout provided by Woodhouse Tinucci Architects and Conservation Design Forum. The layout proposes that the building be located at the west edge of the property, directly adjacent to the south edge of the tennis courts that are intended to remain. The parking lot is being proposed at the south edge of the property with two access drives located on either end of the parking lot, serving main street. The 7'-diameter air release vent will remain undisturbed, and will be located within one of the landscape islands in the parking lot. The remainder of the disturbed area at the northeast portion of the site will be dedicated to the proposed multi-use athletic fields.

#### *Stormwater Detention Analysis*

Two separate geotechnical investigations have been performed on the project site and were used as a basis of design for the proposed stormwater management facilities and building location. The first report dated June 30, 2011, took 16 soil boring samples at various locations around the entire site to determine the overall groundwater and soil conditions of the property. The second report dated June 21, 2017, took four soil boring samples specific to the location of the proposed building footprint to determine if the groundwater and soil conditions were suitable for building construction. Therefore, the first report dated June 30, 2011 will solely be used as the basis of design for determining best stormwater management practices onsite.

Based on the soil boring reports it was determined the overall site has a perched groundwater condition located approximately 5 to 6 feet below ground surface (bgs). Recent correspondence with Soil and Material Consultants has confirmed the long term ground water table to be approximately 8' below grade. Per MWRD requirements, 3.5 feet of separation must be maintained between the invert of the stormwater management facilities and the top of the long term groundwater elevation within combined sewer areas. It is therefore recommended the rate control and volume control volumes be stored within multiple facilities onsite to reduce the overall depth required, and to ensure the separation requirement is maintained.

The stormwater detention rate control volume was analyzed using a conservative model generated in HEC-HMS based on the 100-year storm event. The required volume control volume was calculated per the MWRD requirement of one inch per square-foot of impervious area on site, which includes the pavement and building areas. The artificial turf fields were classified as impervious area solely to calculate the required runoff curve number and rate control volume. This area is not included in determining the required volume control volume as it is not truly impervious per MWRD standards.

The Runoff Curve Number (CN) was calculated based on the proposed site layout using the MWRD calculation spreadsheets. Based on an impervious lot coverage of 71%, and the assumption that all pervious areas are comprised of hydrologic group C soils, a CN of 91 was calculated for the developed site. Due to the volume control volume being provided within the proposed detention facilities, the CN was reduced per the MWRD's CN adjustment calculation spreadsheet. The resulting modified CN was determined to be 85. In addition, the City of Evanston requires a release rate of 0.15 CFS/acre. Based on this requirement, the maximum allowable release was calculated to be 2.42 cfs for the 16.13-acre site.

Using the allowable stormwater release rate of 2.42 CFS, the adjusted CN of 85, and rainfall intensities for the 100-year storm event, it was determined using HEC-HMS model, that approximately **6 acre-feet** (261,360 cubic feet) of rate control volume must be provided onsite. Additionally, based on the 5.90 acres of impervious area, it was calculated that **0.49 acre-feet** (21,344 cubic feet) of volume control volume must also be retained on site. The proposed stormwater best management practices (BMP's) as noted on the CDF plans will provide the required volume to meet both the rate and volume control requirements for stormwater management.

#### *Proposed Utility Design:*

It is recommended that all utility connections for the proposed building be made within Dodge Avenue. The building utility connections to Dodge Ave would include potable water, sanitary sewer, electrical, and gas. Low voltage connection location would need to be confirmed with ATT/Comcast to review possible points of connection from the new building. The building's storm service(s) shall be connected to the onsite rate and volume control stormwater facilities to allow the generated runoff to be treated via flow-through

practices prior to discharging into the public sewer system. Due to the layout of the site and the location of the existing storm relief sewers, it is anticipated there will be multiple storm sewer connections from the project to both Lee St and Dodge Ave.

Storm drainage onsite will be the largest component of the onsite utility design. The cost estimate should assume the following for onsite storm drainage:

1. The artificial turf fields will be drained with 1" x 12" HDPE flat drains placed on the turf field subgrade. The flat drains will be placed approximately 26' on center. 12"-15" PVC-SDR 26 perforated collector pipes will be placed at the edges of the turf field and be connected to the HDPE flat drains.
2. The majority of storm piping onsite will be Reinforced Concrete Pipe and PVC SDR 26 pipe. Ductile iron pipe will be used at crossings with other utilities and at the connections in Lee and Dodge.
3. Catch basins shall be placed every 7500 sq ft of onsite drainage area in paving areas and every 20,000 sq ft in landscape areas.
4. The access drive to Lee St will slope down toward the building and be below typical site grade. For this reason, a duplex storm lift station should be added to the project to drain this area until the hydraulics and stormwater management plan are confirmed.



## LANDSCAPE

**LANDSCAPE BRIEF**

Landscape Scope per plans as indicated in Issued for SD drawing set, dated 08.11.17

**STRUCTURAL**

**STRUCTURAL BRIEF**

Structure per plans as indicated in Issued for SD drawing set, dated 08.11.17

**MECHANICAL  
PLUMBING  
FIRE PROTECTION**



**Smith + Andersen**

4211 Yonge Street Suite 500 Toronto Ontario M2P 2A9  
416 487 8151 f 416 487 9104 [smithandandersen.com](http://smithandandersen.com)

**MECHANICAL REPORT**

**FOR  
NEW ROBERT CROWN COMMUNITY CENTER  
EVANSTON, IL**

**OUR PROJECT NUMBER:**  
17302.000.M.001

**DATE:**  
2017-08-11

**ISSUED / REVISION:**  
ISSUED FOR SCHEMATIC DESIGN – REV 0

**MECHANICAL REPORT**

Project Name: Robert Crown Community Center  
S+A Project No.: 17302.000.M.001

2017-08-11  
Page 2

**LIMITS OF LIABILITY ASSOCIATED WITH THIS DOCUMENT**

**1. THIRD PARTY USE**

- 1.1. Any use that a third party makes of this document, or reliance on or decisions to be based on it, are the responsibility of such third party. Smith + Andersen accepts no responsibility for damages, if any, suffered by any third party as a result of decisions made or actions based upon this document.

**2. GENERAL LIMITS**

- 2.1. This document has been prepared solely for the use of the City of Evanston and its design team associated with New Robert Crown Community Center. The material contained in this document reflects Smith + Andersen's best judgement in light of the information available at the time of preparation. There is no warranty expressed or implied. Professional judgement was exercised in gathering and assessing information. The recommendations presented are the product of professional care and competence and cannot be construed as an absolute guarantee.
- 2.2. Where expected or anticipated equipment life is provided it is based on ASHRAE Median Service Life statistics. Actual life of equipment may vary depending on variables such as operation, service and maintenance frequency.
- 2.3. Where equipment sizing is provided it should be considered order-of-magnitude only as the project details that may affect systems (e.g. envelope quality, occupancy loads, equipment loading) sizing have not been established or finalized.

**MECHANICAL REPORT**

Project Name: Robert Crown Community Center  
S+A Project No.: 17302.000.M.001

**1. INTRODUCTION**

**1.1. DESCRIPTION**

1.1.1. A proposed multi-purpose community center located in Evanston, Illinois, to be owned and operated by the City of Evanston.

1.1.2. The building will be approximately 130,000 square feet (SF) above grade and 2 stories tall. Approximate building height is 30 feet from average grade to the floor of the roof level.

1.1.3. The Facility includes the following features:

- .1 Twin-pad Arena (including associated change rooms, viewing/seating, etc.)
- .2 Gymnasium (including associated change rooms, viewing/seating, etc.)
- .3 Multi-Purpose Rooms/Spaces
- .4 Concessions spaces
- .5 Library

1.1.4. Notable Sustainable Design Features

.1 The base mechanical design incorporates energy conservation and sustainable design measures in order reduce the building's operating costs, lower the impact it will have on the outdoor environment and improve the quality of the indoor environment. Some of the measures incorporated or to be considered are as follows,

**.2 WATER USAGE**

.1 Low flow fixtures shall be used throughout to minimize water usage. Refer to the plumbing section for performance values.

**.3 HEAT RECOVERY**

.1 Areas within the building with air handling systems that have high exhaust rates (change rooms) will be equipped with exhaust air to outside air heat recovery to minimize the energy used to heat the ventilation air.

.2 The arena refrigeration plant will reject waste compressor heat into a thermal storage tank where it will be re-used for use in the rink under floor heating (freeze protection) system, ice resurfacers snow melt pit and other building heating loads.

**.4 EQUIPMENT IMPROVEMENTS**

.1 All mechanical cooling equipment will be CFC and HCFC free.

.2 All new supply fans will be selected to operate at a static efficiency of 60% or greater.

.3 Condensing boilers are being used for heating water which improves combustion efficiencies up to over 90% with best in class performance at part loads

.4 Ultra-high efficiency motors shall be specified throughout.

.5 Variable frequency drives shall be used on pumping and fan systems to save considerable energy at part loads as described in the HVAC systems section

**.5 INDOOR AIR QUALITY**

.1 Ventilation systems shall meet the requirements of ASHRAE 62.1



**MECHANICAL REPORT**

Project Name: Robert Crown Community Center  
 S+A Project No.: 17302.000.M.001

**2. DESIGN STANDARDS**

**2.1. GENERAL**

2.1.1. Mechanical systems shall be designed and installed to maximize usable space within the building while maintaining optimum service clearances for maintenance and repair.

2.1.2. All equipment and materials shall be designed and installed in a neat and orderly fashion. In finished areas all mechanical systems shall be concealed.

**2.2. LEED/ENERGY CONSERVATION**

2.2.1. The project shall use an "Integrated Design Approach" to meet the sustainability requirement of LEED (Current applicable version). The requirements for and level of LEED certification is defined in the General Architectural Requirements for the project as Silver.

**2.3. CODES AND STANDARDS**

2.3.1. Mechanical systems shall be in accordance with applicable codes and standards including, but not limited to:

- .1 Authorities Having Jurisdiction (local building department requirements, local fire department requirements, local by-laws)
- .2 National:
  - .1 Air Conditioning and Refrigeration Institute (ARI)
  - .2 American National Standards Institute (ANSI)
  - .3 American Standard for Testing and Materials (ASTM)
  - .4 American Society of Mechanical Engineers (ASME)
  - .5 American Society of Heating Refrigeration and Air Conditioning Engineers (ASHRAE):
  - .6 National Fire Protection Association (NFPA)
  - .7 Sheet Metal and Air Conditioning Contractors National Association (SMACNA)
- .3 Local:
  - .1 City of Evanston Building Code (OBC)

**2.4. OUTDOOR DESIGN CONDITIONS**

2.4.1. The sizing of mechanical systems shall be based on the outdoor air conditions shown in the following table:

	Dry Bulb Deg.F	Wet Bulb Deg.F	
Cooling	89.0	73.4	ASHRAE 1% [Chicago O'Hare]
Heating	-4.0		ASHRAE 99.6% [Chicago O'Hare]

**MECHANICAL REPORT**

Project Name: Robert Crown Community Center  
 S+A Project No.: 17302.000.M.001

2.5. VENTILATION FOR ACCEPTABLE INDOOR AIR QUALITY

2.5.1. Ventilation to meet acceptable indoor air quality shall be in accordance with ASHRAE Standard 62 and the applicable building code.

2.5.2. Specific minimum outdoor air (OA) ventilation rates are identified in the following table and are equal to the sum of per person value and per SM (SF) value:

	CFM Per Person	CFM/SF	Minimum OA - ACH	Comment
Office	5	0.06		
Meeting/Multi-purpose	5	0.06		
Gymnasium		0.3		
Ice Rink (Playing Surface)	20	0.18		
Ice Rink (Spectator)	7.5	0.06		
Lobby/Circulation	0	0.06		
Shipping	0	0.12		
Storage	0	0.12		

2.6. INDOOR DESIGN CONDITIONS

2.6.1. The indoor space conditions shall be in accordance with the following table:

	Summer		Winter	
	Temperature Deg.F.	Relative Humidity	Temperature Deg.F.	Relative Humidity
Office, Meeting, Multipurpose, Gymnasium, Lobby/Circulation	75 +/-2 Deg.F.	50% +/-5%	72 +/-2 Deg.F.	30% +/-5%
Change Rooms	80 +/-2 Deg.F.	50% +/-10%	80 +/-2 Deg.F.	See Note 1
Ice Rinks	65 +/-2 Deg.F.	40% +/-5%	60 +/-2 Deg.F.	40% +/-5%
Mechanical Rooms	See Note 2	See Note 2	72 +/-2 Deg.F.	See Note 1

Note 1: No humidification is provided to the change rooms or mechanical rooms.

Note 2: Ventilation only. No cooling.

2.6.2. During the programming stage, the equipment provided for each space shall be reviewed in order to establish required cooling. In the event that insufficient equipment information is available the design shall assume the following minimums loads:

	Lighting W/SF	Equipment W/SF	Comments
Office	1.1	2.0	
Meeting/Multi-purpose	1.4	2.0	
Lobby/Circulation	0.5	0.5	

2.7. AIR FILTRATION DESIGN

2.7.1. The following air filtration levels are proposed for the new HVAC air handling systems indicated:

- .1 Exhaust air systems: None

**MECHANICAL REPORT**

Project Name: Robert Crown Community Center  
 S+A Project No.: 17302.000.M.001

- .2 Exhaust air systems c/w Heat Recovery           MERV 7 (Formerly 30%)
- .3 Supply air systems (Pre Filters):               MERV 7 (Formerly 30%)
- .4 Supply air systems (Final Filters):           MERV 14 (Formerly 95%)

2.7.2. Kitchen exhaust (grease laden) that cannot be exhaust at a suitable location to avoid entrainment of odours shall be equipped with ecology units.

2.7.3. Environmental discharges (i.e. exhausts) that are regulated shall be submitted by the Owner to the Authorities having Jurisdiction for the appropriate approval.

**2.8. NOISE DESIGN CRITERIA**

2.8.1. All mechanical systems and components shall be designed and installed with attention to reducing sound and vibration levels to meet noise criteria and provide a space that is comfortable, acoustically, for the occupants.

2.8.2. Noise levels due to mechanical equipment, ductwork, grilles, registers, terminal devices, and diffusers shall be design not to exceed the recommended ASHRAE limit listed below for the areas indicated:

	NC (low)	NC (high)	Comments
Office	30	35	
Meeting/Multi-purpose	30	35	
Lobby/Circulation	35	40	
Property Line		45	

2.8.3. The identified noise criteria resulting from the operation of mechanical systems assumes a finished room with all the final architectural finishes (e.g. ceilings and floor finishes) and furniture in place.

2.8.4. The acoustic performance of the project including mechanical systems shall be reviewed by the acoustical consultant.

**2.9. SYSTEM REDUNDANCY**

2.9.1. There shall be N+1 redundancy (Components - N - have at least one independent backup component +1) applied to the following systems:

- .1 Heating water pump system;
- .2 Storm sump pumps;
- .3 Sanitary sump pumps;
- .4 Arena cold floor pumps

**3. HVAC**

**3.1. GENERAL**

3.1.1. The heating, ventilation and air conditioning (HVAC) design and installation shall conform to current applicable codes and standards and shall be sized by recognized computation procedures referenced in ASHRAE.

**MECHANICAL REPORT**

Project Name: Robert Crown Community Center  
S+A Project No.: 17302.000.M.001

2017-08-11  
Page 7

- 3.1.2. Distribution pumps shall be duplex, lead/lag systems (two pumps sized at 100% of the peak design circulation rate) to provide redundancy during times of service.
- 3.1.3. Variable flow distribution systems shall utilize variable frequency drives (VFD) on the distribution pumps and two-way control valves at the terminal devices. Minimum system flow rates shall be maintained either by including three-way control valves at a sufficient number of terminal devices or by installing a two-way (bypass) control valve across the supply and return mains modulated by a differential pressure controller.
- 3.2. HEATING SYSTEM
- 3.2.1. The central boiler plant shall consist of three ultra-high efficiency, condensing, gas-fired, forced draft boilers each sized for approximately 50% of the total heating water requirement. Each boiler shall be sized for approximately 3,000,000 Btu/hr input. Boilers shall be equal to Patterson-Kelley, DeDetrich, Buderus or Viessmann.
- 3.2.2. The heating plant shall be sized to serve:
- .1 Perimeter envelope losses.
  - .2 Building air handling unit heating coils.
  - .3 Reheat, if required.
  - .4 Entrance heating.
- 3.2.3. The heating water pumping system shall be primary/secondary.
- 3.2.4. The primary system shall consist of one pump dedicated to each boiler.
- 3.2.5. Secondary heating water pump sets (run/standby) shall vary flow in response to building requirements through the use of variable speed drives. Secondary systems shall be provided for:
- .1 Perimeter heating (supply water temperature shall be adjusted in relationship with outdoor air through the building automation system).
  - .2 Building air handling unit heating coils supply water temperature shall be adjusted in relationship with outdoor air through the building automation system.
- 3.2.6. The heating plant including boilers and distribution pumps shall be on **emergency power (if available)**.
- 3.2.7. Heating coils not subjected to below freezing conditions shall be serviced by the heating water system.
- 3.2.8. Heating coils subjected to below freezing conditions shall be serviced by a glycol heating system complete with plate and frame heat exchanger and glycol distribution pumps. Glycol shall be 40% ethylene glycol by volume.
- 3.2.9. Perimeter heating shall be provided by in-floor radiant heating or sill/pedestal mounted perimeter heating with custom enclosure.
- 3.2.10. Entrances and service spaces shall be heated by force flow heating water cabinets or unit heaters.
- 3.2.11. Loading dock and similar type doors shall be equipped with overhead electric air curtains that shall be switched to start when the door is opened.
- 3.2.12. Where used, radiant floor heating system shall consist of high density cross-linked polyethylene tubing embedded into the flooring structure/system. System shall be complete with distribution manifolds, circuit isolation and balancing valves, and controls.

**MECHANICAL REPORT**

Project Name: Robert Crown Community Center  
S+A Project No.: 17302.000.M.001

2017-08-11

Page 8

Tubing shall be rated for not less than 180 deg. F. working temperature and 100 psig working pressure.

- 3.2.13. Chemical treatment systems including pipe line filters shall be provided for all heating water systems.
- 3.3. COOLING SYSTEM
- 3.3.1. Cooling for the Multi-Purpose/Circulation, Library, Gymnasium and Gymnasium Change Rooms shall be generated by direct expansion (DX) cooling coils located in roof mounted air conditioning units with air-cooled condensers located on the roof. Refer to Air Handling Units section.
- 3.4. COOLING SYSTEM
- 3.4.1. Cooling for the Arenas and Arena Change Rooms shall be generated by water-cooled condenser units located indoors. Refer to Air Handling Units section.
- 3.5. HVAC REFRIGERATION SYSTEMS
- 3.5.1. Refrigeration systems shall be in accordance with CSA B52 or ASHRAE Standard 15.
- 3.5.2. Refrigerant piping passing through different fire zones (e.g. vertical pipe shaft between floors shall be fire rated).
- 3.6. HUMIDIFICATION
- 3.6.1. Humidification for the Multi-Purpose/Circulation, Library and Gymnasium shall be accomplished through the use of electric humidifiers.
- 3.7. AIR HANDLING SYSTEMS
- 3.7.1. Ice Rink Units
- .1 Ice rink units shall be indoor desiccant dehumidification units. The dehumidification unit shall establish a humidity level in the arena of 40% RH at 60 Deg.F. for the beginning of any event.
  - .2 A variable volume ventilation module shall be provided within the dehumidification unit to ensure proper air quality. A time of day schedule shall determine night setback or shutdown and a unit mounted CO<sub>2</sub> sensor shall be provided to satisfy rink occupancy requirements by modulating the supply of outdoor ventilation air as part of a demand control ventilation routine.
  - .3 Units shall be equal to Munters, CDI, Haakon or Engineered Air.
  - .4 The unit shall consist of dampers, mixing section, filters, heating section, DX cooling coil, water cooled condenser section, desiccant wheel, process air preheat coil (fed from refrigeration plant recovered heat), process air condenser coil for desiccant wheel reactivation, energy recovery wheel, supply fan, and exhaust fan. Cooling and dehumidification capacities shall be sized on the anticipated peak outdoor air ventilation rate. The unit heating section shall consist of a low temperature heating coil section re-using refrigeration system reclaimed heat.

**MECHANICAL REPORT**

Project Name: Robert Crown Community Center  
 S+A Project No.: 17302.000.M.001

.5 System capacities shall be as follows:

	Supply Airflow CFM	Moisture Removal Lb/hr	Supplemental Exhaust CFM	Comments
AHU-1	5,750	200	3,300	Serves Rink 1
AHU-3	14,000	750	3,300	Serves Rink 2

.6 Acoustical concerns shall be addressed as described in the Noise and Vibration Control Section.

3.7.2. Outdoor Air Heat Recovery (Arena)

- .1 Conditioned ventilation/outdoor air shall be supplied by a 100% outdoor air, constant air volume indoor air handling unit with heat recovery section to reclaim/reject waste heat from exhaust air streams.
- .2 Unit shall consist of dampers, filters, enthalpy wheel, DX cooling coil, water cooled condenser section, glycol heating section, supply fan and exhaust fan.
- .3 Commercial units shall be equal to Daikin, Trane, York, or Engineered Air.
- .4 System capacities shall be as follows:

	Airflow CFM	Cooling Tons	Heating MBH	Comments
AHU-2	9,575	30	870	Serves Arena Change Rooms

- .5 The DX air conditioning shall have more than one stage of cooling for control over supply air temperature. It shall also be equipped with hot gas bypass.
- .6 Change Room exhaust systems shall consist of anodised aluminum ductwork and shall exhaust the air from the shower and fixture areas through the enthalpy wheel in the roof top unit.
- .7 Individual change rooms shall each be provided with a duct-mounted hot water heating coil to maintain space temperature.
- .8 Acoustical concerns shall be addressed as described in the Noise and Vibration Control Section.

3.7.3. Variable Air Volume Units (Library, Circulation, and Gymnasium)

- .1 Variable air volume (VAV) units shall be roof-mounted and shall recirculate air from the space to the air handler unit, mix with outdoor air, filter, heat or cool and supply to the space. The unit shall be capable of 100% outdoor air for free cooling (economizer mode) when the ambient conditions permit.
- .2 Units shall consist of dampers, mixing section, filters, DX cooling coil, air cooled condenser section, glycol heating coil, humidifier, supply fan with variable speed drive, and separate return fan with variable speed drive.
- .3 Commercial units shall be equal to Daikin, Trane, York, or Engineered Air.
- .4 System capacities shall be as follows:

	Airflow L/S (CFM)	Cooling Tons	Heating MBH	Comments
RTU-1	20,475	56	430	Serves Circulation and MP
RTU-2	12,750	37	320	Serves Library
RTU-4	19,475	60	570	Serves Gymnasium

.5 The DX air conditioning shall have more than one stage of cooling for control over supply air temperature. It shall also be equipped with hot gas bypass.

**MECHANICAL REPORT**

Project Name: Robert Crown Community Center  
 S+A Project No.: 17302.000.M.001

- .6 The ceiling space shall form a return air plenum. Return air shall be through light fixtures, approved grilles, and/or additional perimeter architectural return air slots provided in the hung ceiling plenums. Return air shall be transferred into the compartment unit room via silencers.
- .7 [Library and Circulation Units] Variable volume control shall be achieved using a variable speed drive (VSD) on the supply fan. A static pressure sensor in the discharge duct shall control the VSD. Supply and return fan air monitoring shall adjust return fan VSD to maintain required airflow differential.
- .8 [Gymnasium Unit] The unit shall be a single zone variable air volume unit achieved using a variable speed drive (VSD) on the supply fan. Space temperature shall control the VSD. Supply and return fan air monitoring shall adjust return fan VSD to maintain required airflow differential.
- .9 See Variable Air Volume Terminal Devices section.
- .10 Acoustical concerns shall be addressed as described in the Noise and Vibration Control Section.

3.7.4. Variable Air Volume (VAV) Terminal Devices

- .1 Terminal room control shall be fan powered variable air volume boxes with electrically commuted motors (ECM) and hot water coils equal to E.H.Price or Titus. Non-fan powered variable volume boxes may be used for interior zones without heating requirements.
- .2 Units shall be equal to E.H.Price or Titus with direct digital control.
- .3 Acoustical concerns shall be addressed as described in the Noise and Vibration Control Section.

3.7.5. Outdoor Air Heat Recovery (Warm Change Rooms)

- .1 Conditioned ventilation/outdoor air shall be supplied by a 100% outdoor air, constant air volume roof-mounted air handling unit with heat recovery sections to reclaim/reject waste heat from exhaust air streams.
- .2 Unit shall consist of dampers, filters, enthalpy wheel, DX cooling coil, glycol heating coil, supply fan and exhaust fan.
- .3 Commercial units shall be equal to Daikin, Trane, York, or Engineered Air.
- .4 System capacities shall be as follows:

	Airflow CFM	Cooling Tons	Heating MBH	Comments
RTU-2	1,950	6.0	175	Serves Warm Change Rooms

- .5 The DX air conditioning shall have more than one stage of cooling for control over supply air temperature. It shall also be equipped with hot gas bypass.
- .6 Change Room exhaust systems shall consist of anodised aluminum ductwork and shall exhaust the air from the shower and fixture areas through the enthalpy wheel in the roof top unit.
- .7 Individual change rooms shall each be provided with a duct-mounted hot water heating coil to maintain space temperature.
- .8 Acoustical concerns shall be addressed as described in the Noise and Vibration Control Section.

**MECHANICAL REPORT**

Project Name: Robert Crown Community Center  
S+A Project No.: 17302.000.M.001

2017-08-11  
Page 11

3.7.6. Kitchen Ecology Systems

- .1 Kitchen exhaust that cannot be expelled at a location (i.e. roof) which shall prevent re-entrainment shall be equipped with an ecology filter system complete with carbon filtration for additional odour control. The ecology unit shall be complete with an NFPA-96 compliant suppression system.
- .2 Ductwork upstream of the ecology unit shall meet the requirements of NFPA-96.
- .3 Ductwork downstream of the ecology unit shall meet the requirements of NFPA-96.
- .4 Multiple hoods installed in separate fire zones (e.g. floors) shall be served by independent exhaust systems.

3.7.7. Miscellaneous Systems

- .1 Elevator machine and controller rooms shall be provided with split system cooling units capable of operation at low ambient temperatures. Hydraulic and machine-less elevator machine rooms shall be exhausted to maintain at a negative pressure to maintain ventilation air into the room.
- .2 Separate washroom exhaust systems shall be provided for the washroom groups if they are not attached to heat recovery systems. The make-up shall be transferred from the adjacent corridors.
- .3 Ventilation systems, comprising filtered outdoor and an exhaust air fan, shall be provided for the mechanical and electrical rooms. Each system shall cycle the fan to maintain a space temperature.
- .4 Self-contained air conditioning units shall be provided for server/LAN rooms.
- .5 An exhaust fan tied into the ammonia leak detection system shall be provided in the refrigeration room.
- .6 An exhaust fan controlled from a space mounted carbon dioxide (CO) sensor shall be provided in the Ice Resurfacer circulation/storage areas to ensure safe air quality.
- .7 Exhaust system of suitable construction shall be provided for dishwasher exhaust.

3.8. NOISE AND VIBRATION CONTROL

- 3.8.1. All mechanical equipment shall be equipped with vibration isolation control measures to reduce the transfer of vibration generated noise into the building structure.
- 3.8.2. All supply, return and exhaust air system shall be equipped with silencers to reduce the duct borne equipment noise in the occupied spaces to acceptable NC levels.

3.9. INSULATION

- 3.9.1. Insulation for HVAC systems shall be in accordance with ASHRAE 90.1.

**4. PLUMBING**

4.1. GENERAL

- 4.1.1. The Plumbing System shall conform to the applicable building code.



**MECHANICAL REPORT**

Project Name: Robert Crown Community Center  
S+A Project No.: 17302.000.M.001

2017-08-11  
Page 12

- 4.1.2. All exterior site services including external cisterns shall be provided under the "Site Works" contract. Scope of work for this Division shall end at 5 ft. (60 inch) outside building perimeter
- 4.1.3. Above floor storm drains, sanitary drains and vents, 2-1/2 inch and larger shall be cast iron.
- 4.1.4. Above floor sanitary drains and vents, 2 inch and smaller shall be hard temper DWV copper drainage tubing.
- 4.1.5. Buried storm piping within the building shall be PVC.
- 4.1.6. Buried sanitary piping within the building shall be PVC.
- 4.1.7. Domestic water piping shall be copper type L.
- 4.1.8. Valves shall be Crane or equal of type and construction to suit service and working pressures.
- 4.1.9. For all services 2 inch and smaller 600 psig WOG ball valves shall be used.
- 4.2. **STORM SYSTEMS**
  - 4.2.1. A complete system of roof drains and storm drainage piping shall be provided.
  - 4.2.2. New above grade drains shall be collected and drained by gravity to site storm sewers.
  - 4.2.3. Weeping tile shall be collected in settling sumps and transferred to sump pits complete with duplex submersible pumps. Pits shall be pumped into site services storm drainage system. Sump pumps shall be on **emergency power** (if available).
  - 4.2.4. To accurately and appropriately size the sump pits and pumps, the geotechnical consultant should provide flow rates based on the soil tests/borehole results.
  - 4.2.5. The civil consultant shall prepare the storm water management (SWM) approach for the site, which may determine that a retention storm cistern is required.
- 4.3. **SANITARY SYSTEMS**
  - 4.3.1. A complete system of plumbing fixtures and sanitary drainage and vent piping shall be provided.
  - 4.3.2. New above grade drains shall be collected and drained by gravity to site sanitary sewers. Drains below the municipal services invert elevations shall be collected in sump pits complete with duplex submersible pumps. Pits shall be pumped into the gravity drainage piping. Sump pumps shall be on **emergency power** (if available).
- 4.4. **GREASE INTERCEPTOR**
  - 4.4.1. Grease interceptors shall be complete with an alarm to indicate when pump out is required.

**MECHANICAL REPORT**

Project Name: Robert Crown Community Center  
 S+A Project No.: 17302.000.M.001

4.5. PLUMBING FIXTURES

4.5.1. The following plumbing fixtures are anticipated for the project:

	Group	Description	Comments
W-1	Water Closet	Wall mounted, electronic flush valve	
W-2	Water Closet	Wall mounted, barrier free, electronic flush valve	
U-1	Urinal	Wall hung, electronic flush valve	
L-1	Lavatory	Counter mounted, electronic "no touch" 4 inch centre set.	
L-2	Lavatory	Counter mounted, barrier free, electronic "no touch" 4 inch centre set.	
JS-1	Janitor Sink	Precast floor mounted, faucet with hose set.	
S-1	Sink	Counter mounted, single bowl, stainless steel, 8 inch centre set.	
S-2	Sink	Counter mounted, double bowl, stainless steel, 8 inch centre set.	
SH-1	Shower	Pressure balanced mixing valve, floor or trench drain.	
SH-2	Shower	Pressure balanced mixing valve, barrier free with three fixed showerheads mounted at different heights with diverter valve, floor drain.	
DF-1	Drinking Fountain	Wall mounted, barrier free, non-refrigerated with bottle filler.	

4.5.2. Plumbing fixtures shall be water conserving type. Minimum (Refer to LEED/ENERGY CONSERVATION) baseline requirements:

	Imperial	Comments
Water Closets	1.6 Gallons per flush	
Urinals	1.0 Gallons per flush	
Lavatories (Public)	0.5 GPM @ 60 psig	
Lavatories (Private)	2.2 GPM @ 60 psig	
Showerheads	2.5 GPM	

4.6. DOMESTIC COLD WATER

4.6.1. A 4 inch) domestic water service shall be brought into the building for domestic water and fire services. The domestic water and fire services shall be isolated from the municipal water supply by approved backflow prevention devices.

4.7. DOMESTIC HOT WATER

4.7.1. Domestic hot water shall be generated by gas-fired storage water heaters located in the mechanical room. Water heaters shall be equal to PVI complete with storage tank and gas-fired heat exchanger capable of raising incoming domestic water through 100 deg.F.

4.7.2. A replaceable bladder expansion tank suitable for domestic hot water shall be installed on the domestic hot water system to accommodate thermal expansion.

**MECHANICAL REPORT**

Project Name: Robert Crown Community Center  
S+A Project No.: 17302.000.M.001

4.7.3. A recirculation loop and recirculation pump shall maintain flow in the domestic hot water system to maintain hot water at the fixtures at all time.

4.8. TEMPERED WATER

4.8.1. A tempered water distribution shall be provided for emergency showers and eyewashes. Tempered water shall be maintained at 75 deg.F. Tempered water shall be "Potable" water.

4.9. NATURAL GAS

4.9.1. Natural gas shall be distributed to the kitchen and boiler room as required. All gas piping shall be schedule 40. Piping 2-1/2 inch and larger shall be welded. All gas piping shall be painted yellow in its entirety including concealed areas.

4.9.2. High pressure 5 psig shall serve the boiler room. A low pressure PRV station at approximately 7 to 11 in.WC. shall be provided to serve the kitchen.

4.10. INSULATION

4.10.1. Insulation for plumbing systems shall be in accordance with ASHRAE 90.1.

4.10.2. All exposed insulation shall be complete with PVC jacket or canvas lagging suitable for painting.

**5. FIRE PROTECTION AND LIFE SAFETY SYSTEMS**

5.1. GENERAL

5.1.1. The Fire Protection System shall conform to the applicable building code.

5.2. SPRINKLER

5.2.1. A wet pipe, hydraulically sized sprinkler system shall be installed for the building. Sprinkler design shall be to NFPA 13.

Discussion:  
The owner should confirm with their insurer that other standards such as Factory Mutual (FM) or Insurance Advisory Organization (IAO) are not required.

5.2.2. Sprinkler heads shall be:

- .1 Upright brass type where no ceiling exists.
- .2 Concealed type where ceilings occur.
- .3 Provided with guards in exposed areas where heads are susceptible to damage.

5.2.3. All piping 2-1/2 inch and larger shall be schedule 40 with Victaulic fittings.

5.2.4. All piping 2 inch and smaller shall be screwed.

**MECHANICAL REPORT**

Project Name: Robert Crown Community Center  
 S+A Project No.: 17302.000.M.001

5.2.5. The following sprinkler zones and coverage is anticipated.

Area	Type	Hazard	Remarks
Offices and Multi-Purpose	Wet	Light	
Gymnasium	Wet	Ordinary GR 1	Guards on heads
Arenas and Change Rooms	Dry	Ordinary GR 1	
Mechanical Rooms, Storage Rooms	Wet	Ordinary GR 1	

5.2.6. All supervised valves shall have end switches. The Electrical Division shall wire valves and switches into the main fire alarm panel.

**5.3. STANDPIPE SYSTEMS**

5.3.1. At this point the building is not expected to require a fire standpipe system complete with fire hose cabinets. An independent code review shall confirm this at a later date.

**5.4. SPRINKLER AND STANDPIPE WATER SERVICE**

5.4.1. Fire department siamese connection shall be provided for the sprinkler system and shall be located near the main fire department entrance and not to exceed 150 feet from a fire hydrant.

**5.5. PORTABLE FIRE EXTINGUISHERS**

5.5.1. General areas including offices shall be covered by water type extinguishers. Mechanical rooms, electrical rooms and similar spaces shall be provided with chemical fire extinguishers.

**5.6. NATURAL GAS GENERATOR SYSTEMS**

5.6.1. The emergency generator shall be a pre-packaged, exterior unit complete with all required ventilation.

**5.7. SEISMIC REQUIREMENTS**

5.7.1. The seismic requirements for the mechanical system components and their connections to the structure is still to be determined.

**6. SYSTEM CONTROLS**

**6.1. Building Automation System (BAS)**

6.1.1. A microprocessor system incorporating direct digital control shall be installed to control and monitor the mechanical systems. The BAS shall be BACNET or Echelon compliant where possible.

6.1.2. The BAS shall control and monitor air handlers, exhaust fan, heating and cooling equipment, and terminal units. The BAS shall interface with chillers, cooling towers, and boilers. The BAS shall monitor sump pits, temperature in critical common areas, etc.

6.1.3. The building operator's terminal shall be located in the building operator's room.

**MECHANICAL REPORT**

Project Name: Robert Crown Community Center  
S+A Project No.: 17302.000.M.001

2017-08-11

Page 16

**7. AIR AND WATER BALANCING**

7.1.1. All air and water systems shall be balanced prior to building turn-over. Balancing reports shall be submitted for review by the consultant and owner.

**8. COMMISSIONING**

**8.1. CONTRACTOR COMMISSIONING**

8.1.1. Contractor shall perform equipment testing (piping, ductwork) and obtain sign-offs, equipment start-up and check sheet (with manufacturers), arrange for training on equipment (provided to owner) and coordinate with independent commissioning agent.

**8.2. INDEPENDENT COMMISSIONING**

8.2.1. To be determined.

**9. MECHANICAL AND ELECTRICAL CO-ORDINATION**

9.1. Motor starters shall be supplied and installed by Division 16. Starters shall be grouped into motor control centres or starter racks where feasible. Power wiring (line side and load side) shall be by Division 16.

9.2. Variable speed drives shall be supplied and installed by Division 15. Power wiring (load and line) shall be by Division 16.

9.3. Control wiring shall be by Division 15.

9.4. All fire alarm wiring shall be by Division 16. All smoke detectors including duct-mounted smoke detectors, integral with the fire alarm system, shall be supplied and installed by Division 16.

END OF MECHANICAL DESIGN BRIEF



**ELECTRICAL**



**Smith + Andersen**

4211 Yonge Street Suite 500 Toronto Ontario M2P 2A9  
416 487 8151 f 416 487 9104 [smithandandersen.com](http://smithandandersen.com)

**ELECTRICAL REPORT**

**FOR  
NEW ROBERT CROWN COMMUNITY CENTER  
TWIN PAD ARENA  
EVANSTON, IL**

**OUR PROJECT NUMBER:  
17302.000.E001**

**DATE:  
2017-08-11**

**ISSUED / REVISION:  
ISSUED FOR SD COSTING – REV 1**



**LIMITS OF LIABILITY ASSOCIATED WITH THIS DOCUMENT**

**1. THIRD PARTY USE**

- 1.1. Any use that a third party makes of this document, or reliance on or decisions to be based on it, are the responsibility of such third party. Smith + Andersen accepts no responsibility for damages, if any, suffered by any third party as a result of decisions made or actions based upon this document.

**2. GENERAL LIMITS**

- 2.1. This document has been prepared solely for the use of MJMA and its design team associated with the New Twin Pad Arena. The material contained in this document reflects Smith + Andersen's best judgement in light of the information available at the time of preparation. There is no warranty expressed or implied. Professional judgement was exercised in gathering and assessing information. The recommendations presented are the product of professional care and competence and cannot be construed as an absolute guarantee.
- 2.2. Where equipment sizing is provided it should be considered order-of-magnitude only as the project details that may affect systems have not been established or finalized.

**1. INTRODUCTION**

- 1.1. A proposed new Twin Pad Arena Community Center (“Facility”) located in Evanston, Illinois. The building will be an Assembly Group A-3 & A-4 classification.
- 1.2. The Facility is to be owned by the City of Evanston.
- 1.3. Building is to be approximately 130,000 square feet and 2 storeys tall.
- 1.4. The Facility includes the following main features:
  - 1.4.1. Twin pad ice rink arena
  - 1.4.2. Gym
  - 1.4.3. Multi-purpose/Community/Fitness/Preschool rooms
  - 1.4.4. Library
  - 1.4.5. Administration rooms

**2. DESIGN STANDARDS**

- 2.1. The Electrical systems will be designed in accordance with the current edition of the following Codes and Standards:
  - City of Evanston Building Code
  - International Building Code (IBC) 2012
  - National Electrical Code (NEC) 2011
  - National Fire Protection Authority (NFPA)
  - International Energy Conservation Code (IECC) 2015
  - Local Ordinances and Authorities
  - Institute of Electrical and Electronic Engineers (IEEE) standards
  - LEED
  - Illumination Engineering Society (IES) Standards
  - ASHRAE 90.1 “Energy Efficient Design of New Buildings”
  - Commonwealth Edison (ComEd)

**3. NORMAL POWER DISTRIBUTION**

- 3.1. The local distribution authority is Commonwealth Edison (ComEd).
- 3.2. A new incoming service to the new Facility will be provided at 480V, 3 phase, 4 wire via a new exterior pad-mounted, utility supplied 1500 kVA transformer. The exterior transformer will be located at the north-west corner of the building. **(TRANSFORMER SIZE AND LOCATION TO BE CONFIRMED WITH LOCAL HYDRO).**
- 3.3. The primary high voltage utility feeders to the utility transformer will come below ground in a concrete duct bank off of Main Street to the south, OR Dodge Avenue to the west **(LOCATION TO BE CONFIRMED WITH LOCAL HYDRO).**

- 3.4. From the utility pad-mounted transformer, a secondary concrete encased duct bank will enter the building to the Main Electrical Room and terminate in the Main 480/277V Switchboard.
- 3.5. Utility metering to be done on the Main 480/277V Switchboard, where it will have a utility CT/PT's compartment c/w metering cabinet located next to the switchboard.
- 3.6. Our design will be based on power density calculations as required by the National Electrical Code (NEC).
- 3.7. Electrical rooms will be located in the following locations and contain the following list of equipment:
- 3.7.1. Main Electrical Room (Ground Floor):
- .1 2400A, 480/277V, 3PH, 4W Main Switchboard
  - .2 Hydro Utility Metering Cabinet
  - .3 600A, 480V, 3 phase fused disconnect switch for future solar photovoltaic (PV) connection (**TO BE CONFIRMED WITH OWNER**)
  - .4 800A, 480V, 3 phase distribution panel (City)
  - .5 150kVA, 480V:120/208V distribution transformer (City)
  - .6 600A, 120/208V, 3 phase, 4 wire power panel (City)
  - .7 200A, 120/208V lighting panel (City)
  - .8 225A, 120/208V receptacle panel (City)
  - .9 400A, 480V, 3 phase distribution panel (Library)
  - .10 75kVA, 480V: 120/208V distribution transformer (Library)
  - .11 400A, 120/208V, 4 wire power panel (Library)
  - .12 100A, 480V, 3PH, 3W Automatic Transfer Switch (life safety emergency)
  - .13 100A, 480V, 3PH, 3W Distribution Panel (life safety emergency)
  - .14 45kVA, 480:120/208V distribution transformer (life safety emergency)
  - .15 225A, 120/208V, 3PH, 4W Power Panel (life safety emergency)
  - .16 100A, 120/208V, 3PH, 4W Lighting Panel (life safety emergency)
  - .17 100A, 480V, 3PH, 3P Automatic Transfer Switch (non-life safety emergency)
  - .18 100A, 480V, 3PH, 3W Distribution Panel (non-life safety emergency)
  - .19 45 kVA, 480:120/208V, 3PH Transformer (non-life safety emergency)
  - .20 225A, 120/208V, 3PH, 4W Power Panel (non-life safety emergency)
  - .21 100A, 120/208V, 3PH, 4W Receptacle Panel (non-life safety emergency)
- 3.7.2. Ground Floor Sub-Electrical Room #1 (Ice Rink):
- .1 400A, 480V, 3PH, 3W Distribution Panel
  - .2 75 kVA, 480:120/208V, 3PH Transformer
  - .3 400A, 120/208V, 3PH, 4W Power Panel
  - .4 225A, 120/208V, 3PH, 4W Receptacle Panel
  - .5 100A, 120/208V, 3PH, 4W Lighting Panel
  - .6 100A, 120/208V, 3PH, 4W Lighting Panel (life safety emergency)
  - .7 100A, 120/208V, 3PH, 4W Receptacle Panel (non-life safety emergency)

- 3.7.3. Ground Floor Sub-Electrical Room #2 (Change Rooms/Preschool Rooms):
- .1 100A, 480V, 3PH, 3W Distribution Panel
  - .2 45 kVA, 480:120/208V, 3PH Transformer
  - .3 225A, 120/208V, 3PH, 4W Power Panel
  - .4 225A, 120/208V, 3PH, 4W Receptacle Panel
  - .5 100A, 120/208V, 3PH, 4W Lighting Panel
  - .6 100A, 120/208V, 3PH, 4W Lighting Panel (life safety emergency)
  - .7 100A, 120/208V, 3PH, 4W Receptacle Panel (non-life safety emergency)
- 3.7.4. Ground Floor Sub-Electrical Room #3 (Library):
- .1 400A, 480V, 3PH, 3W Distribution Panel
  - .2 112.5 kVA, 480:120/208V, 3PH Transformer
  - .3 400A, 120/208V, 3PH, 4W Power Panel
  - .4 225A, 120/208V, 3PH, 4W Receptacle Panel
  - .5 100A, 120/208V, 3PH, 4W Lighting Panel
  - .6 100A, 120/208V, 3PH, 4W Lighting Panel (life safety emergency)
  - .7 100A, 120/208V, 3PH, 4W Receptacle Panel (non-life safety emergency)
- 3.7.5. Second Floor Sub-Electrical Room #4 (Mech Boiler):
- .1 400A, 480V, 3PH, 3W Distribution Panel
  - .2 45 kVA, 480:120/208V, 3PH Transformer
  - .3 225A, 120/208V, 3PH, 4W Power Panel
  - .4 225A, 120/208V, 3PH, 4W Receptacle Panel
  - .5 100A, 120/208V, 3PH, 4W Lighting Panel
  - .6 100A, 120/208V, 3PH, 4W Lighting Panel (life safety emergency)
  - .7 100A, 120/208V, 3PH, 4W Receptacle Panel (non-life safety emergency)
- 3.7.6. Second Floor Sub-Electrical Room #5 (Gym/MP Rooms):
- .1 100A, 480V, 3PH, 3W Distribution Panel
  - .2 45 kVA, 480:120/208V, 3PH Transformer
  - .3 225A, 120/208V, 3PH, 4W Power Panel
  - .4 225A, 120/208V, 3PH, 4W Receptacle Panel
  - .5 100A, 120/208V, 3PH, 4W Lighting Panel
  - .6 100A, 120/208V, 3PH, 4W Lighting Panel (life safety emergency)
  - .7 100A, 120/208V, 3PH, 4W Receptacle Panel (non-life safety emergency)
- 3.8. The Concession and Kitchen/Catering space will have dedicated 225A, 120/208V, 3PH, 4W panels (normal).
- 3.9. The Main Incoming Telecommunications will have a dedicated emergency 100A, 120/208V, 3PH, 4W electrical panel (non-life safety emergency).

- 3.10. The Refrigeration Room will also have a 800A, 480V, 3PH, 3W feeder to connect to a Motor Control Centre (MCC) for refrigeration equipment serving the arena. The MCC will be provided and installed by the Refrigeration Contractor.
- 3.11. The primary distribution voltage, throughout the facility will be 480V for the major mechanical loads and 120/208V for lighting/plug loads.
- 3.12. The Main Electrical Room, all sub-electrical rooms and electrical closets will have a minimum 1-hour fire rating.
- 3.13. All electrical equipment is to be sprinkler proof.
- 3.14. Interior wiring shall be RW90 insulated copper. Exterior wiring shall be RWU90 insulated copper. A separate insulated ground wire shall be provided in each conduit. Branch circuits conductors shall be solid, minimum #12 AWG
- 3.15. All electrical conductors are to be copper. However electrical conductors rated at 200A or greater are acceptable to be aluminium: NUAL or similar.
- 3.16. All equipment to be copper bus.

#### 4. EMERGENCY POWER DISTRIBUTION

- 4.1. Emergency power will be provided by a natural gas generator with a main breaker on the generator supplying a splitter/main distribution panel, which will supply individual feeds to the life safety system and non-life safety system.
- 4.2. The generator will be 150 kW standby rated.
- 4.3. The generator will be exterior mounted, housed in a suitable weather-proof sound attenuated enclosure. The generator will be located outdoors on the roof of the building or at grade level near the Main Electrical Room (**LOCATION TO BE CONFIRMED WITH ARCHTIECT**).
- 4.4. The life safety automatic transfer switch and distribution system will supply the following systems:
  - Life safety lighting systems required by Building Code
  - Exit Lighting
  - Fire Alarm network panels
- 4.5. The non-life safety automatic transfer switch and distribution system will supply the following systems:
  - Sanitary pumps
  - Storm water pumps
  - Sump pumps
  - Security System
  - Telephone system
  - Hands free urinals, faucets and toilets

- 4.6. The emergency transfer switch will be 3 phase, 3-pole, contactor style, with electronic controller, generator start signal, load-dump relays and elevator pre-transfer inhibit signal.
- 4.7. Emergency power will meet the minimum operation requirements for a period of no less than 30 minutes. However since the fuel system is proposed to be natural gas, it will have an unlimited fuel supply as long as the gas utility does not have a major supply interruption.
- 4.8. All life safety emergency wiring (i.e. main feeders to the emergency lighting panels) is to be rated for a minimum of one hour. Branch circuits to emergency lights being fed from an emergency panel located on the same storey do not need to be fire rated.

## 5. FIRE ALARM

- 5.1. The building will be provided with an addressable single stage OR two stage **(TO BE CONFIRMED WITH OWNER)** fire alarm system with battery charger and standby batteries.
- 5.2. The main fire alarm control panel will be located in the Main Incoming Telecom Room.
- 5.3. A remote annunciator panel complete with EVAC controls will be provided at the fire fighter's entrance.
- 5.4. All fire alarm detection and addressable loop wiring will be class A. All output device wiring will be Class B.
- 5.5. EVAC speakers and speaker-strobes will be provided throughout the building.
- 5.6. Visual strobes will be installed in public and common areas, employee work areas, and in other floor areas where required by code.
- 5.7. Visual strobes will also be utilized in areas of high ambient noise including all mechanical rooms.
- 5.8. Primary means of detection will be via manual pull stations and the sprinkler system. Smoke and heat detectors will be provided where required by Building Code.
- 5.9. All manual pull stations in the unheated ice rink area will be conventional type devices, as addressable devices are not rated for cold temperatures.
- 5.10. The fire alarm will monitor the following systems:
- Standby emergency generators (Trouble/running)
  - Gas supply line feeding the emergency generator
  - The kitchen fire suppression system.
- 5.11. All magnetic locks (if applicable) will be released upon activation of the evacuation signal on the fire alarm.

- 5.12. Duct-type smoke detectors will be supplied in air handling systems that serve more than one floor or suite fire separation. Air handling equipment will be designed to shut down upon activation of its dedicated duct detector or the fire alarm system.
- 5.13. The sprinkler system will be electrically supervised via flow switches and supervised valves.
- 5.14. Smoke detectors will be provided in all elevator lobbies, elevator shaft and pit, and the elevator machine room.
- 5.15. The complete fire alarm system will be tested, verified and commissioned as per the requirements of the Building Code.

## 6. LIGHTING

- 6.1. High efficiency luminaires will be provided as per the recommendations of the IES.
- 6.2. All light fixtures will be LED type.
- 6.3. Lighting will be designed to OBC and IESNA requirements.
- 6.4. The Lobby and public circulation area lighting will suit architectural elements and provide average illumination levels of 200-250 lux. The luminaires will consist of mainly linear LED fixtures in continuous runs in the ceiling. Suspended pendants may also be provided at reception and other feature areas.
- 6.5. Washroom and change room lighting will be either surface mounted fixtures in areas with no ceilings or linear LED fixtures in continuous runs in areas with ceilings providing illumination levels to 250 lux.
- 6.6. Shower area luminaires will be LED, sealed and gasketed fixtures with lenses, suitable for wet environments providing illumination levels to 250 lux.
- 6.7. Service rooms lighting shall be suitably lit with chain hung LED strip fixtures with lenses as required.
- 6.8. Gymnasium lighting shall be designed to Class III recreational to provide 500 lux with a uniformity of 3:1 or less using high output LED luminaires with a glare control and an impact resistant lens suspended from the structure.
  - 6.8.1. Multi-purpose/Community/Fitness/Preschool rooms shall be designed to provide 300 lux with a uniformity of 3:1 or less using LED luminaires.
- 6.9. Lighting in ice rinks shall be **IES Class III**, designed to 750 lux illumination utilizing high bay LED luminaires with high impact lenses suspended from the arena ceiling. Dimmable lighting fixtures will be used in ice rinks with at least two lighting zones to suit different application.
- 6.10. Library and Administration areas shall be designed to 300 lux using direct/indirect fixtures at workstation level.

- 6.11. Luminaires in parking area are to provide 22 lux average at driving areas with a uniformity of 3:1 and 10 lux minimum with a uniformity of 4:1 at the parking and pedestrian areas.
- 6.12. Stairwells will be illuminated by diffuse LED luminaires.
- 6.13. Emergency lighting will be provided to meet building code and will be provided in electrical and mechanical services rooms.
- 6.14. Exterior lighting will be complete with shielding to ensure glare control and light trespass to passers by and neighbouring properties. Full cut-off LED luminaires to ensure illumination with no spillage of light above the horizontal plane or onto adjacent properties.
- 6.15. Exit lights will be energy efficient LED type. In the Ice Rinks and Change Rooms the exit lights shall be in heavy duty Lexan enclosures. Edge lit exit signs will be used in all other areas.

## **7. LIGHTING CONTROL**

- 7.1. A centralized low voltage lighting control system will be provided for the facility, including LV switches, occupancy sensors, photo sensors and time-clocks. The low voltage lighting control system will be Wattstopper Digital Light Management (DLM) or equal.
- 7.2. Washrooms, storage rooms, office areas and any other areas with transient occupancy will be provided with ceiling or wall mounted occupancy sensors.
- 7.3. Exterior lighting will be automatically controlled capable of turning off exterior lighting when sufficient daylight is available or when the lighting is not required during night time hours.
- 7.4. Motion sensor to be PIR, Ultrasonic or a combination sensor with a capability to add slaves. These will be wall mounted in small single occupant rooms/offices and ceiling mounted in all other areas.
- 7.5. In areas with natural lighting, luminaires will be controlled by daylight sensors to make maximum use of natural light. Daylight sensors to dim fixtures.
- 7.6. Mechanical and electrical room lighting shall be controlled by standard wall switches.
- 7.7. Night lighting circuits will be provided in all major circulation corridors to allow the movement of cleaning staff through the area without the need to turn on all the lights within the space. This will be achieved by using the emergency lights that will be act as the "night lighting" circuits.
- 7.8. All emergency lighting will be controlled with the normally powered lights in the same rooms/space and will be done using a UL 924 listed emergency relay to force the emergency lighting ON in the event of a power failure.
- 7.9. Lighting in the lobby and public circulation areas will be controlled via a master switch located at reception.



**8. METERING**

- 8.1. A networked digital based electric power meter with embedded webpage will be provided on the Main 480/277V Switchboard. The power meter will have the capability with demand metering measure peak kW, kVA, ampacity, etc.

**9. GROUNDING SYSTEM**

- 9.1. An AC grounding system with new main ground electrode that will consist of a minimum of four 3m ground rods spaced 3m apart will be provided at the exterior pad-mounted transformer. The grounding conductors will be a minimum #2/0AWG and connect to the utility transformer with two separate min. #2/0AWG ground connections.
- 9.2. In addition, the Main Electrical Room will have the main building electrical ground grid that will consist of a minimum of four 3m ground rods spaced 3m apart and connected to the main electrical ground bar located in the Main Electrical Room. The grounding conductors will be a minimum #2/0AWG.
- 9.3. The grounding system for the building will be extended by connecting each typical electrical room to the main grounding system in the main electrical room in a radial connection. A ground bar will be provided in each electrical room. All transformer neutrals will be connected to the grounding bar and a common cable connected back to the system ground.
- 9.4. Grounding will be provided following IEEE 1100 and Electrical Code standards.
- 9.5. Separate #3/0AWG telecommunication ground riser will be provided off of the main building ground bus and the telecommunication ground riser will be connected in a radial pattern with ground bars in each telecommunication room.

**10. EMI CONSIDERATIONS**

- 10.1. All wiring will be in conduit. All major normal power feeds will be in totally enclosed metal bus duct.
- 10.2. Routing of power cables and bus duct will be selected to minimize the effect of magnetic fields on other equipment.
- 10.3. Single conductor Teck or armoured cable will be avoided.

**11. COMMUNICATIONS SYSTEM INFRASTRUCTURE**

- 11.1. Three (3) 100mm (4") underground ducts will be installed from the property line to the Main Telecommunications Room located at the Ground Level by the Electrical Contractor. The Main Telecommunications (Telco) Room will be act as a termination point for all incoming telecommunications service connections to the building. It will serve as a transition point between outside plant service provider infrastructure and Owner provided interior infrastructure. The minimum recommended room size is 10' x 10'. This room shall contain the equipment for the telephone/internet/CATV services/systems.

- 11.2. It is the responsibility of the Owner to arrange for all required incoming services including any voice/data and CATV connections from service providers. This includes cabling infrastructure from the service providers existing street network to the demarcation room as well as any ongoing service contracts.
- 11.3. Communications rooms will be located in the following locations:
  - .1 Main Incoming Telco Room – Ground Floor
  - .2 IT Room #1 (City) – Ground Floor
  - .3 IT Room #2 (Library) – Ground Floor
  - .4 IT Room #3 (City) – Second Floor
  - .5 IT Room #4 (City) – Second Floor
- 11.4. The Telco Room will have its walls covered in 3/4" plywood backboard for ease of mounting any associated equipment.
- 11.5. An empty conduit infrastructure will be provided for the communications system by the Electrical Contractor, consisting of two 101mm (4") conduits from the Main Telco Room to each IT Room. Pull boxes will be provided at 30m intervals.
- 11.6. All data and voice outlet drops will run back to the Main Telco Room or nearest IT Room with a minimum 1" conduit.
- 11.7. Voice and data outlet boxes shall be provided by the Electrical Contractor, with minimum 27mm conduit (1") to the nearest zone conduit or Comm/IT Room from each workstation, at the main circulation desk workstations and in multi-purpose rooms
- 11.8. Installation and final connection of all telephone and data outlets and cabling will be by the Owner or their Communications Contractor.
- 11.9. An empty conduit and back-box infrastructure will be provided for Wi-Fi.
- 11.10. Communications rooms will be provided with dedicated circuits and receptacles.
- 11.11. J-hooks and zone conduits will be provided throughout the main corridors to circle the floor and interconnect the IT room to the various areas on the same floor.

**12. SECURITY SYSTEM INFRASTRUCTURE**

- 12.1. Rough in conduit and junction box system will be provided for the security system by the Electrical Contractor. Also doors contacts, electric strikes, magnetic locks, and security cameras will be roughed-in by the Electrical Contractor. All electronic devices, wiring and installation of security equipment will be by the Owner or their Security Contractor.
- 12.2. Locations of doors contacts, electric strikes, magnetic locks, and security cameras will be done by the Owner or their Security Consultant/Contractor.
- 12.3. The security system will include conduit rough-in for an Access Control, a Video Surveillance (CCTV), and Panic/Duress Alarm Systems.

- 12.4. All security conduits to be homerun back to the main Telco Room and/or nearest Comm/IT Room with a minimum of 3/4" conduit, except for CCTV cameras where the conduit size will be 1".

**13. AUDIO-VIDEO (AV) INFRASTRUCTURE**

- 13.1. An empty conduit infrastructure complete with back boxes will be provided by the Electrical Contractor for all cable TV and AV system equipment system.
- 13.2. Provision, installation and final connection of all audio visual outlets and cabling will be by the Owner/Owner's Installer.

**14. CO-ORDINATION OF MECHANICAL AND ELECTRICAL AND OTHERS**

- 14.1. All starters, fire alarm shutdown, pressurization control, smoke evacuate control, motor control centres, and power wiring shall be by the electrical division except for units with starters as part of a package or for VFDs.
- 14.2. All power wiring shall be by the Electrical contractor including power wiring from variable speed drives to motors. VFDs to be mounted on or near the equipment and VFD cable will be run from the VFD drive to the motor with no disconnect between them.
- 14.3. All control wiring and controls shall be by Mechanical contractor. The Electrical contractor will provide 15A, 120V, 1 phase circuits at designated panels and they will be terminated in a junction box near the respective electrical panels. The Mechanical/Controls contractor is required to extend the 120V circuits to all of their respective equipment.
- 14.4. All fire alarm wiring shall be by Electrical contractor.

END OF ELECTRICAL DESIGN BRIEF

17302.000.e001.db002.docx



## **SPECIALTIES: AUDIO VISUAL**

## AUDIO/VISUAL BRIEF

### 1. INTRODUCTION

- A. The Facility includes the following main components:
  - 1. Arena component (twin pad arenas, change rooms, etc.)
  - 2. Recreation (gymnasium, fitness room, change rooms, etc.)
  - 3. Library
  - 4. Multi-Purpose rooms (art, meetings, events/parties)
  - 5. Shared spaces (lobby, kitchen, etc.)
- B. Audiovisual systems consist of public address loudspeakers, flat-panel displays, projection systems, microphone systems and associated equipment, cabling and hardware.

### 2. LOBBY

- A. Two 60" flat panel displays shall be provided in the lobby entrance to the arena. These displays are intended to show events and schedule.
- B. The above displays will be fed by content players that will be provided by the City of Evanston. The content players will have HDMI or DVI outputs for the displays. The City of Evanston will install and configure all software required. These players will be located in the arena office.

### 3. MAIN RECEPTION DESK

- A. The arena office or main reception desk will be main control center for the PA system of the following spaces:
  - 1. Rink 1
  - 2. Rink 2
  - 3. Change Rooms East (Rink 1)
  - 4. Change Rooms West (Rink 2)
  - 5. Rink 1 Viewing Area
  - 6. Rink 2 Viewing Area
- B. A media player will be provided for background music to Arena spaces. The media player will allow users to provide one of the following sources for background music in the spaces:
  - 1. AM/FM Radio
  - 2. Compact Disc
  - 3. Bluetooth Audio
  - 4. USB/SD Card file playback
  - 5. Auxiliary Input
- C. A gooseneck microphone will be provided for paging within the arena spaces and change-rooms.
- D. A control interface will be provided. The control interface will allow for the following
  - 1. Volume control for each zone described in 3.1
  - 2. Paging microphone destination selection/routing
  - 3. Source inputs volume control (Media player, paging volume, and timekeeper source)
- E. All AV equipment will be located within a local equipment rack, in a location in the office which will be easy for users to access.

**4. RINK1 AND RINK 2**

- A. Each rink will feature a sound system that consists of high output speakers as shown on drawings.
- B. An audio input location and volume controller for the input and viewing area speakers will be provided in the timekeeper box. The audio input location will allow for the connection of hardwired microphone and an iPod-style portable music device.
- C. An audio digital signal processor (DSP) will be provided to allow for the routing of audio signals within the area. The DSP will be used for equalization and calibration of all the audio zones within the facility.
- D. Audio amplifiers will be provided to drive the local speakers and will be located in the central equipment rack.
- E. Surface-mounted speakers will be provided to support playback from audio sources and will service the arena ice areas.
- F. Surface-mounted speakers will be provided to support playback from audio sources and will service the Rink 1 viewing area.
- G. Ceiling-mounted speakers will be provided to support playback from audio sources and will service the Rink 2 viewing area.
- H. Ceiling-mounted speakers will be provided to support playback from audio sources and will service the change rooms.
- I. All head-end equipment and an equipment rack shall be located within an IT room (location TBD).

**5. GYMNASIUM**

- A. The gymnasium will be an area used for indoor recreation and multi-purpose uses. The PA system will provide audio playback for instructors during these classes.
- B. An audio input location shall be provided as shown on drawings.
- C. An audio digital signal processor (DSP) will be provided to allow for the routing of audio signals within the area. The DSP will be used for equalization and calibration of all the audio zones within the facility.
- D. An audio amplifier will be provided to drive the local speakers and will be located in the central equipment rack.
- E. Ceiling mounted speakers shall be provided for sound reinforcement.
- F. An equipment rack shall be located within the room. An input plate at the top of the rack shall allow instructors to plug an iPod into the sound system.
- G. A wall-mount button panel shall allow for simple source selection and volume control. Paging through the fire alarm system shall mute the sound system for emergency notification.
- H. Paging through the fire alarm system shall mute the sound system for emergency notification.

**6. FITNESS/DANCE ROOM**

- A. The fitness room will be an area used for fitness classes. The PA system will provide audio playback for instructors during these classes.
- B. An audio input location shall be provided as shown on drawings.
- C. An audio digital signal processor (DSP) will be provided to allow for the routing of audio signals within the area. The DSP will be used for equalization and calibration of all the audio zones within the facility.
- D. An audio amplifier will be provided to drive the local speakers and will be located in the central equipment rack.
- E. Ceiling mounted speakers shall be provided for sound reinforcement.
- F. An equipment rack shall be located within the room. An input plate at the top of the rack shall allow instructors to plug an iPod into the sound system.
- G. A wall-mount button panel shall allow for simple source selection and volume control. Paging through the fire alarm system shall mute the sound system for emergency notification.

H. Paging through the fire alarm system shall mute the sound system for emergency notification.

**7. LIBRARY MEETING ROOMS**

- A. The library meeting room will be used for local presentations.
- B. A 60" flat screen display shall be wall mounted and provided in each meeting room.
- C. A connection within the furniture top for laptop audio and video input shall be provided.
- D. Flat panel display shall have microphone and camera for video-conferencing.

**8. MULTIPURPOSE ROOMS**

- A. All audiovisual for the multipurpose room shall be portable equipment provided by others (not in scope of the project).
- B. Projection paint (Screen Goo) shall be provided to allow for a surface conducive to high quality projection experience. Portable projectors shall be provided by others.

**9. PRE-SCHOOL**

- A. A ceiling recessed motorized 109" projection screen shall be provided.
- B. A ceiling mount projector shall be provided by others. Owner to supply projector and mount, including specifications to consultant for coordination with overall room design. The audiovisual contractor shall install, test and commission the projector.
- C. A wall-plate shall be provided for laptop audio and video input.
- D. A wall-mounted button panel shall be provided for audiovisual system control.
- E. Paging through the fire alarm system shall mute the sound system for emergency notification.

**10. 2ND LEVEL LOUNGE/WAITING AREA**

- A. A 90" flat panel display, with mounting, for cable TV viewing shall be provided for the second level lounge/waiting area as shown on drawings.
- B. A cable terminal or satellite receiver will be supplied by the City of Evanston and installed by the AV contractor



**11. ITEMS IN THE SCOPE OF OWNER/OTHERS**

- A. Owner shall supply TV receivers, distribution, and cabling as required.
- B. Refer to the following table for the division of responsibility for IT department regarding AV systems:

IT Systems Information	
Phone System:	Information to be provided by City of Evanston
Digital Signage Players/Content Management Engine	Information to be provided by the City of Evanston/Evanston Public Library

AV / IT Division of Responsibility Matrix		
System Type	AV Contractor	IT
Audio System Interface with Phone System	<ul style="list-style-type: none"> <li>- Hardware Installation (Microphones, speakers, signal processors)</li> <li>- Adapter Configuration</li> </ul>	<ul style="list-style-type: none"> <li>- Telephone Systems Configuration</li> <li>- Allocation of Telephone Drop and Activation</li> <li>- Call Manager Configuration</li> </ul>
Digital Signage (flat panels that show content)	<ul style="list-style-type: none"> <li>- Hardware Installation</li> </ul>	<ul style="list-style-type: none"> <li>- Signage Player Configuration</li> <li>- Network Configuration Bandwidth Management</li> <li>- Allocation of Network drop and Activation</li> <li>- Installation, Configuration and Management of Content Management Software</li> <li>- Installation Configuration and Management of Content Creation Software</li> </ul>

<b>Lobby</b>			
Items	Description	Model	Quantity
Video – Display	60" Professional LCD Display, 1080p	Sharp or eq	2
Video – Mount	Large Fusion micro-adjustable tilting wall mount	Chief or eq	2
Video – Extender	HDMI extension kit	Crestron or eq	2
Video – Source	Scheduling PC	(by owner)	1
General	Cable, Connectors, Hardware	General	1
Programming	Control System	Custom	1
Install			1

<b>Rink 1 and Rink 2</b>			
Items	Description	Model	Quantity
Audio - DSP	Audio Digital Signal Processor, with 8 inputs, 8 flex & 8 outputs, POTS	QSC or equal	1
Audio - DSP	Expansion unit with 2 inputs, 2 outputs and onboard amplifier	QSC or equal	1
Audio - DSP	Wallmounted PoE touchscreen - 7"	QSC or equal	1
Audio - DSP	Wallmounted PoE touchscreen - 3"	QSC or equal	2
Audio - Microphone	Desktop Microphone	Shure or equal	1
Audio - Source	Media Player	Denon or equal	1
Audio - Transmitter	Audio Input Twisted Pair Transmitter (XLR and 2xRCA)	RDL or equal	2
Audio - Receiver	Audio Twisted Pair Receiver	RDL or equal	2
Audio - Speaker (Office)	6" ceiling mounted loudspeaker	QSC or equal	1
Audio - Speaker (Rink Viewing)	6" surface mounted loudspeaker	QSC or equal	4
Audio - Speaker (Rink Viewing)	6" ceiling mounted loudspeaker	QSC or equal	6
Audio - Amplification	4-channel amplifier, 400-watt per, with DSP	QSC or equal	1
Audio - Speaker (Rink)	6" surface mounted loudspeaker	QSC or equal	16
Audio - Speaker (Rink)	Brackets for above	QSC or equal	16
Audio - Amplification	4-channel amplifier, 1150-watt per, with DSP	QSC or equal	2
Audio - Speaker (Changeroom)	Loudspeaker, 8"	Atlas or equal	26
Audio - Speaker (Changeroom)	Backbox for above	Atlas or equal	24
Audio - Speaker (Changeroom)	Baffle for above	Atlas or equal	24

Audio - Speaker (Changeroom)	Mount flanged enclosure	Atlas or equal	2
Audio - Amplification	2-channel amplifier, 500-watt per	Atlas or equal	1
Control - Switch	8-port PoE network switch	Cisco or equal	1
General	AV Equipment rack	Middle Atlantic or eq	1
General	UPS battery unit	Middle Atlantic or eq	1
General	Rackmounted power distribution	Middle Atlantic or eq	1
General	Cable, Connectors & Hardware	General	1
Programing	Control System	Custom	1
Installation			1

<b>Gymnasium</b>			
Items	Description	Model	Quantity
Audio – DSP	Audio DSP	Extron or equal	1
Audio – Transmitter	Audio Input Twisted Pair Transmitter (XLR and 2xRCA)	RDL or equal	1
Audio – Receiver	Audio Twisted Pair Receiver	RDL or equal	1
Audio – Amplification	4-channel amplifier, 100-watt per	QSC or equal	1
Audio – Speaker	8" ceiling speaker, 70V or 8-ohm operation	Electrovoice or equal	8
Control - Keypad	Mini controller processor	Crestron or equal	1
General	AV Equipment rack	Middle Atlantic or eq	1
General	UPS battery unit	Middle Atlantic or eq	1
General	Rackmounted power distribution	Middle Atlantic or eq	1
General	Cable, Connectors & Hardware	General	1
Programing	Control System	Custom	1
Installation			1

Fitness / Dance Room			
Items	Description	Model	Quantity
Audio – DSP	Audio DSP	Extron or equal	1
Audio – Transmitter	Audio Input Twisted Pair Transmitter (XLR and 2xRCA)	RDL or equal	1
Audio – Receiver	Audio Twisted Pair Receiver	RDL or equal	1
Audio – Amplification	2-channel amplifier, 100-watt per	QSC or equal	1
Audio – Speaker	8" ceiling speaker, 70V or 8-ohm operation	Electrovoice or equal	6
Control - Keypad	Mini controller processor	Crestron or equal	1
General	AV Equipment rack	Middle Atlantic or eq	1
General	UPS battery unit	Middle Atlantic or eq	1
General	Rackmounted power distribution	Middle Atlantic or eq	1
General	Cable, Connectors & Hardware	General	1
Programing	Control System	Custom	1
Installation			1

Pre-School			
Items	Description	Model	Quantity
Video - Projector	Video Projector with std lens, 5,000 lumen	(by owner)	1
Video - Projector Screen	Ceiling recessed tension-tab projection screen, 109", 16:10,	Da-Lite or equal	
Video - Mount	Universal projector mount	Chief or equal	1
Video - Extender	HDMI extension kit	Crestron or equal	1
Control - Keypad	Mini controller processor	Crestron or equal	1
General	Cable, Connectors & Hardware	General	1
Programing	Control System	Custom	1
Installation			1

<b>Library Meeting Rooms</b>			
Items	Description	Model	Quantity
Video – Display	60" Professional LCD Display, 1080p	Sharp or eq	3
Video – Mount	Large Fusion micro-adjustable tilting wall mount	Chief or eq	3
Video – Extender	HDMI extension kit	Crestron or eq	3
Camera	Wall mounted	TBD	3
Audio - Microphone	Wall mounted	TBD	3
General	Cable, Connectors & Hardware	General	3
Programing	Control System	Custom	1
Installation			1

<b>2nd Floor Waiting Area</b>			
Items	Description	Model	Quantity
Video – Display	90" Consumer Display	Sharp or eq	1
Video – Mount	X-Large Fusion micro-adjustable tilting wall mount	Chief or eq	1
General	Cable, Connectors & Hardware	General	1
Programing	Control System	Custom	1
Installation			1



## **SPECIALTIES: SPORT FIELDS**

**SPORT FIELDS**

Synthetic Turf at Concrete Walkway Detail

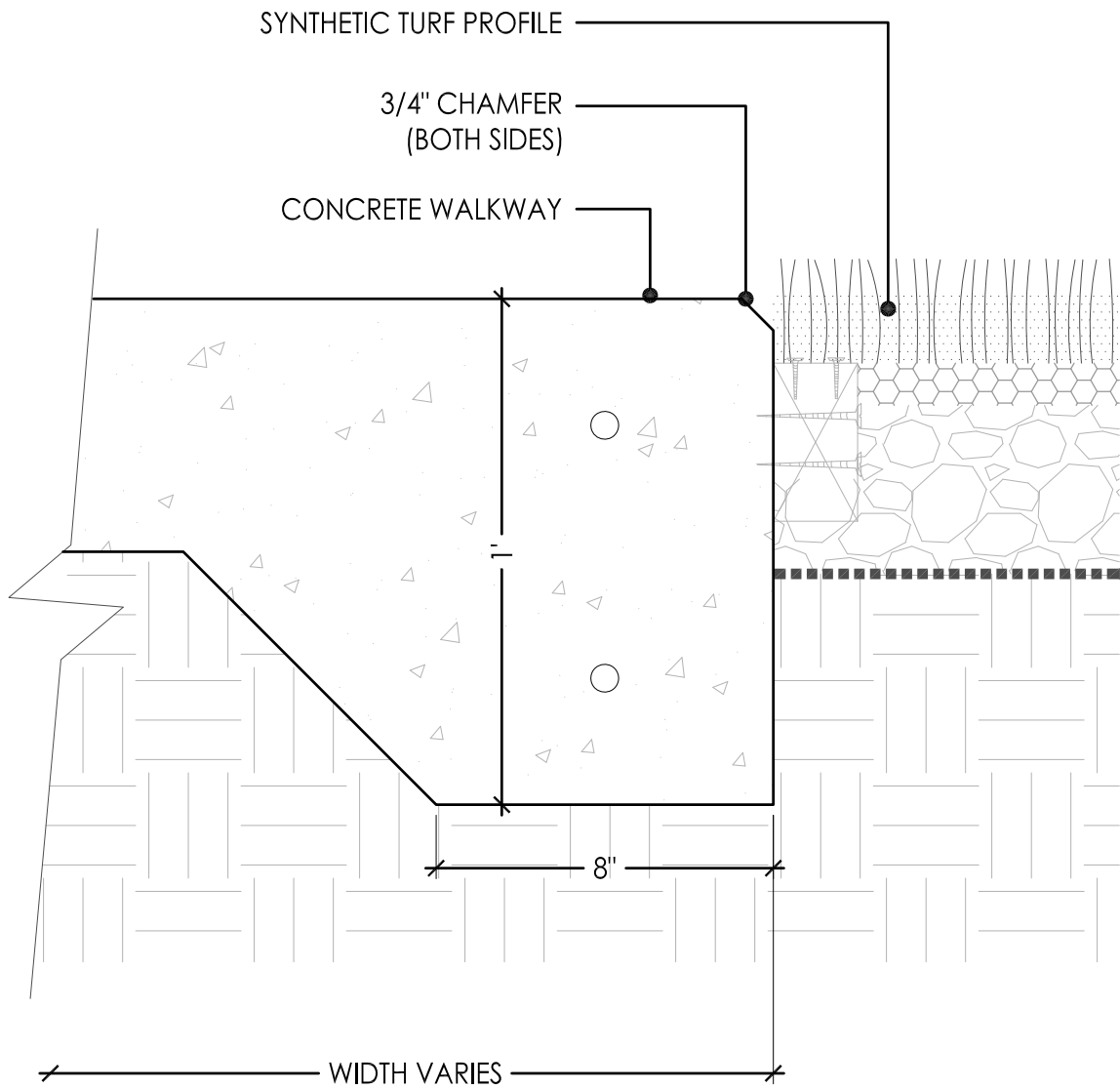



Synthetic Turf at Header Curb Detail

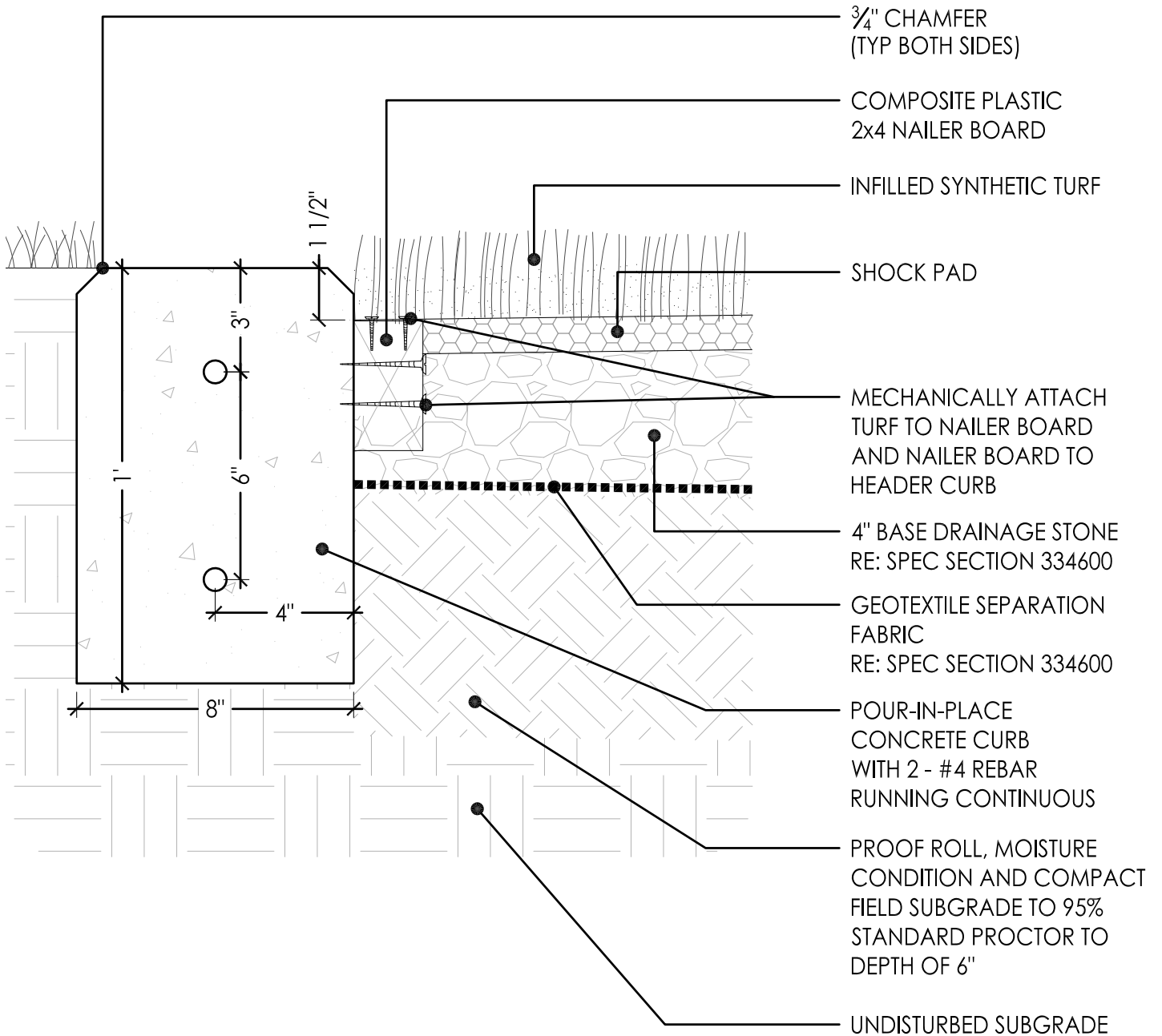

Synthetic Turf at Collector Detail

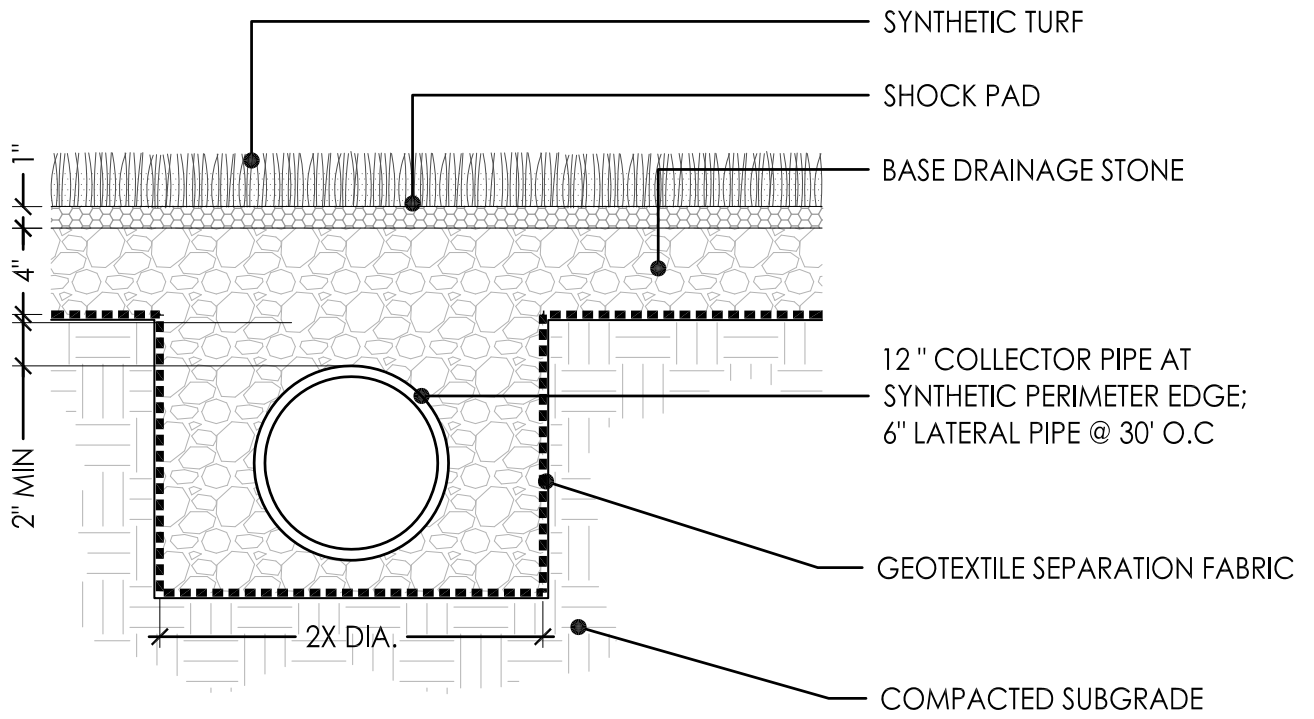

**SPECIALTIES: SPORT LIGHTING**

# Robert Crown Center Soccer Baseball

Evanston, IL

## Lighting System

Pole / Fixture Summary						
Pole ID	Pole Height	Mtg Height	Fixture Qty	Luminaire Type	Load	Group
A1	70'	70'	4	TLC-LED-1150	4.60 kW	B
		70'	1	TLC-LED-1150	1.15 kW	A
		15'	1	TLC-LED-1150	1.15 kW	A
A2	70'	70'	5	TLC-LED-1150	5.75 kW	A
		15'	1	TLC-LED-1150	1.15 kW	A
A3	70'	70'	5	TLC-LED-1150	5.75 kW	D
		15'	1	TLC-LED-1150	1.15 kW	D
A4	70'	70'	4	TLC-LED-1150	4.60 kW	C
		70'	1	TLC-LED-1150	1.15 kW	D
		15'	1	TLC-LED-1150	1.15 kW	D
B1	80'	80'	6	TLC-LED-1150	6.90 kW	B
		15'	1	TLC-LED-1150	1.15 kW	A
B2, C1	80'	80'	10	TLC-LED-1150	11.50 kW	B
		15'	1	TLC-LED-1150	1.15 kW	A
B3	80'	80'	9	TLC-LED-1150	10.35 kW	C
		15'	1	TLC-LED-1150	1.15 kW	D
B4	80'	80'	8	TLC-LED-1150	9.20 kW	C
		15'	1	TLC-LED-1150	1.15 kW	D
C2	80'	80'	10	TLC-LED-1150	11.50 kW	C
		15'	1	TLC-LED-1150	1.15 kW	D
S1	80'	80'	4	TLC-LED-1150	4.60 kW	B
S2	80'	80'	4	TLC-LED-1150	4.60 kW	C
<b>12</b>			<b>91</b>		<b>104.65 kW</b>	

### Group Summary

Group	Description	Avg Load	Max Load	Fixture Qty
A	Baseball 1	12.65 kW	12.65 kW	11
B	Multipurpose 1	39.1 kW	39.1 kW	34
C	Multipurpose 2	40.25 kW	40.25 kW	35
D	Baseball 2	12.65 kW	12.65 kW	11

### Fixture Type Summary

Type	Source	Wattage	Lumens	L90	L80	L70	Quantity
TLC-LED-1150	LED 5700K - 75 CRI	1150W	121,000	>51,000	>51,000	>51,000	91

From Hometown to Professional

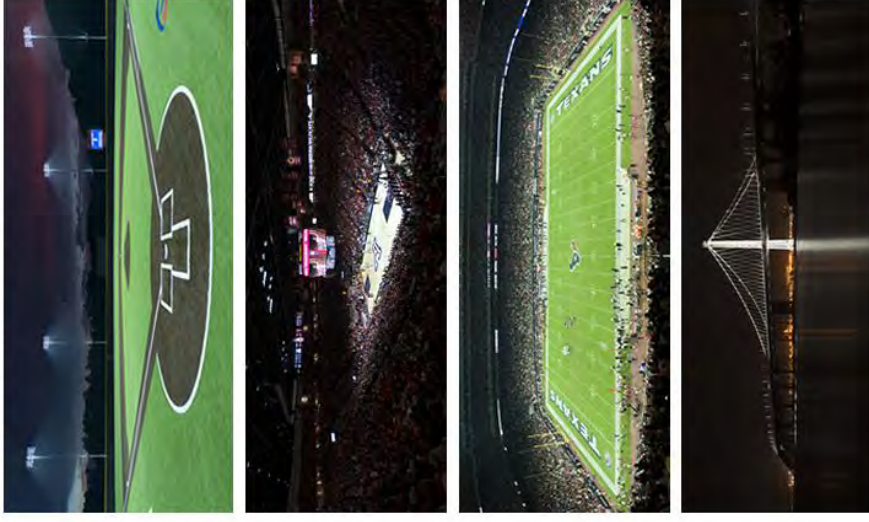

We Make It Happen®

Not to be reproduced in whole or part without the written consent of Musco Sports Lighting, LLC. ©1981, 2017 Musco Sports Lighting, LLC.

# Robert Crown Center Soccer Baseball

Evanston, IL

## Light Level Summary

### Calculation Grid Summary

Grid Name	Calculation Metric	Illumination				Groups	Fixture Qty
		Ave	Min	Max	Max/Min		
Baseball 1 (Infield)	Horizontal Illuminance	51.7	35	62	1.80	A, B	45
Baseball 1 (Outfield)	Horizontal Illuminance	30.7	21	44	2.10	A, B	45
Baseball 2 (Infield)	Horizontal Illuminance	51.9	37	62	1.69	C, D	46
Baseball 2 (Outfield)	Horizontal Illuminance	30.1	21	41	2.00	C, D	46
Property Line Spill	Horizontal Illuminance	0.24	0	6.78	0.00	A, B, C, D	91
Property Line Spill	Max Candela Metric	7785	0	114576	0.00	A, B, C, D	91
Property Line Spill	Max Vertical Illuminance Metric	0.36	0	9.99	0.00	A, B, C, D	91
Roadway Spill Line	Horizontal Illuminance	0.01	0	0.07	0.00	A, B, C, D	91
Roadway Spill Line	Max Candela Metric	917	0	5010	0.00	A, B, C, D	91
Roadway Spill Line	Max Vertical Illuminance Metric	0.02	0	0.12	0.00	A, B, C, D	91
Soccer 1	Horizontal Illuminance	30.2	23	41	1.78	B	34
Soccer 2	Horizontal Illuminance	33.3	23	42	1.80	B, C	69
Soccer 3	Horizontal Illuminance	30.5	20	41	2.04	C	35
Zero Grid	Horizontal	6.08	0	70	0.00	A, B, C, D	91

From Hometown to Professional

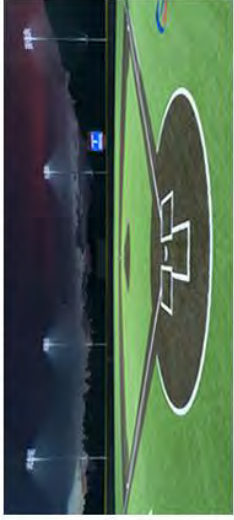

We Make It Happen®

Not to be reproduced in whole or part without the written consent of Musco Sports Lighting, LLC. ©1981, 2017 Musco Sports Lighting, LLC.

# Robert Crown Center Soccer Baseball

Evanston, IL

## EQUIPMENT LAYOUT

- INCLUDES:**
- Baseball 1
  - Baseball 2
  - Soccer 1
  - Soccer 2
  - Soccer 3

**Electrical System Requirements:** Refer to Amperage Draw Chart and/or the "Musco Control System Summary" for electrical sizing.

**Installation Requirements:** Results assume  $\pm 3\%$  nominal voltage at line side of the driver and structures located within 3 feet (1m) of design locations.

## EQUIPMENT LIST FOR AREAS SHOWN

QTY	LOCATION	SIZE	GRADE ELEVATION	MOUNTING HEIGHT	LUMINAIRE		QTY/P POLE	
					TYPE	HEIGHT		
4	A1-A4	70'	-	15'	TLC-LED-1150	1	1	
1	B1	80'	-	70'	TLC-LED-1150	5	5	
3	B2, C1-C2	80'	-	15'	TLC-LED-1150	1	6	
1	B3	80'	-	80'	TLC-LED-1150	10	1	
1	B4	80'	-	15'	TLC-LED-1150	9	1	
2	S1-S2	80'	-	80'	TLC-LED-1150	8	4	
12	TOTALS						91	

## SINGLE LUMINAIRE AMPERAGE DRAW CHART

Ballast Specifications (.90 min power factor)	Line Amperage Per Luminaire (max draw)			
	208 (60)	240 (60)	277 (60)	347 (60)
Single Phase Voltage	208 (60)	240 (60)	277 (60)	347 (60)
TLC-LED-1150	7.0	6.6	6.1	5.2
			4.2	3.8
			3.0	

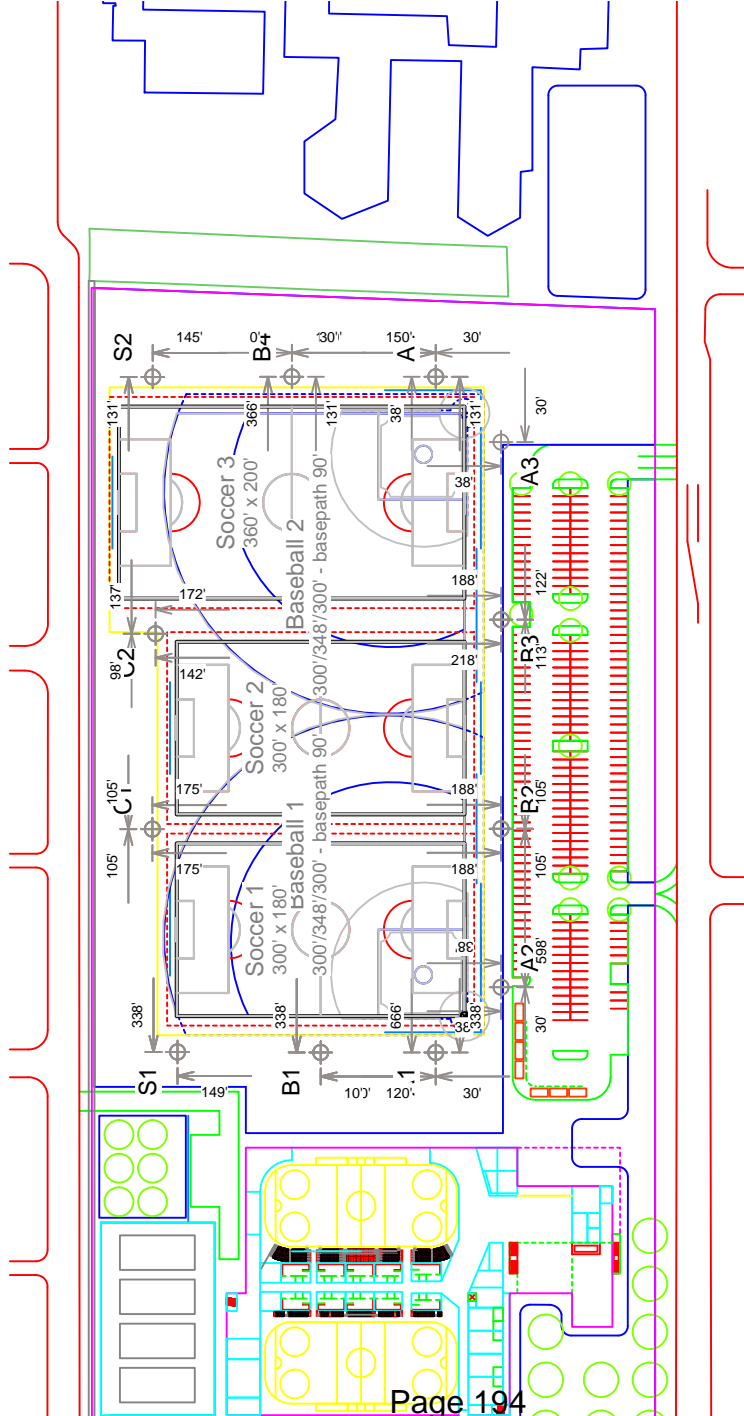

SCALE IN FEET 1 : 200

Pole location(s)  $\oplus$  dimensions are relative to 0,0 reference point(s)  $\otimes$



**We Make It Happen<sup>®</sup>**

Not to be reproduced in whole or part without the written consent of Musco Sports Lighting, LLC. ©1981, 2017 Musco Sports Lighting, LLC.

## EQUIPMENT LAYOUT



# ROBERT CROWN COMMUNITY CENTER ICE COMPLEX AND LIBRARY

EVANSTON, ILLINOIS

## ISSUED FOR SCHEMATIC DESIGN

### general notes

1. IN THE EVENT OF CONFLICT, AMBIGUITY OR INCONSISTENCY IN OR BETWEEN THE ELEMENTS COMPRISING THE CONTRACT DOCUMENTS, NOT CLARIFIED BY A MODIFICATION, THE CONTRACTOR WILL BE DEEMED TO HAVE ESTIMATED ON, AND AGREED TO PROVIDE, THE GREATER QUANTITY OR BETTER QUALITY OF PRODUCTS AND THE WORK IN ACCORDANCE WITH THE ARCHITECT'S INTERPRETATION OF WHICH CONFLICTING REQUIREMENT GOVERN, UNLESS HE SHALL HAVE, BEFORE SUBMISSION OF HIS BID, ASKED AND OBTAINED WRITTEN DECISION OF THE ARCHITECT AS TO WHICH PRODUCTS AND WORK WILL BE REQUIRED.
2. THE GENERAL CONTRACTOR SHALL REPORT TO THE ARCHITECT ANY DISCREPANCIES BETWEEN THE DRAWINGS AND THE ACTUAL CONDITIONS WHICH WOULD INTERFERE WITH COMPLETION OF THE WORK.
3. CONTRACTOR SHALL VERIFY ALL DIMENSIONS AND CONDITIONS SHOWN ON THE DRAWINGS AND SHALL NOTIFY THE ARCHITECT OF ANY INCONSISTENCIES, INACCURACIES, DISCREPANCIES OR CONFLICTS PRIOR TO BID FOR CLARIFICATION.
4. CONTRACTOR SHALL BE RESPONSIBLE FOR PROVIDING ALL ITEMS AND WORK NECESSARY FOR A COMPLETE INSTALLATION OF ALL COMPONENTS WITHIN SCOPE OF WORK WHETHER SPECIFICALLY CALLED OUT IN THESE DRAWINGS OR NOT.
5. THE CONTRACTOR, WITH THE ASSISTANCE OF THE SUBCONTRACTORS SHALL ASSURE THAT ALL WORK AND MATERIALS MEET APPLICABLE LOCAL, COUNTY, STATE OF ILLINOIS AND NATIONAL BUILDING CODES.
6. THE CONTRACTOR IS RESPONSIBLE FOR REMOVAL AND PROPER DISPOSAL OF ALL CONSTRUCTION WASTE AND DEBRIS GENERATED BY CONSTRUCTION. THE JOB SITE SHALL BE KEPT CLEAN AND KEPT FREE OF WASTE MATERIAL FOR THE DURATION OF CONSTRUCTION.
7. THE GENERAL CONTRACTOR SHALL TAKE ALL NECESSARY PRECAUTIONS TO ENSURE THE SAFETY OF THE PUBLIC AND OF THE WORKMEN ON THE JOB. THE GENERAL CONTRACTOR SHALL COMPLY WITH ALL GOVERNING LAWS, ORDINANCES, CODES, RULES, AND REGULATIONS RELATIVE TO PERFORMANCE AND SAFETY.
8. THE CONTRACTOR SHALL READ, UNDERSTAND AND COMPLY WITH ALL SPECIFICATIONS CONTAINED WITHIN.
9. ALL DIMENSIONS ARE ACTUAL AS OPPOSED TO NOMINAL, AND ARE TAKEN FROM COLUMN CENTERLINES AND FACE OF FINISHES.
10. THESE DRAWINGS ARE NOT TO BE SCALED FOR CONSTRUCTION.
11. CONTRACTOR SHALL COORDINATE ALL PENETRATIONS THROUGH, BOX-OUTS IN AND DEPRESSIONS IN CONCRETE FOUNDATIONS, CONCRETE SLABS AND STRUCTURAL STEEL PRIOR TO INSTALLATION. CONTRACTOR SHALL PROVIDE EVIDENCE OF SUCH COORDINATION TO THE ARCHITECT FOR REVIEW PRIOR TO INSTALLATION. CONTRACTOR SHALL COORDINATE SUCH LOCATIONS FROM ALL STRUCTURAL, ARCHITECTURAL, MEP, AND FIRE PROTECTION DRAWINGS AS INDICATED.

### sheet index

- G1.0 GENERAL INFORMATION
- C1.0 SITE DEMOLITION PLAN
- C4.0 GRADING AND DRAINAGE PLAN
- L6.0 SITE PLAN
- S2.0 FRAMING PLAN
- S2.1 FRAMING PLAN
- A3.0 EXTERIOR ELEVATIONS
- A3.1 BUILDING SECTIONS

### location map

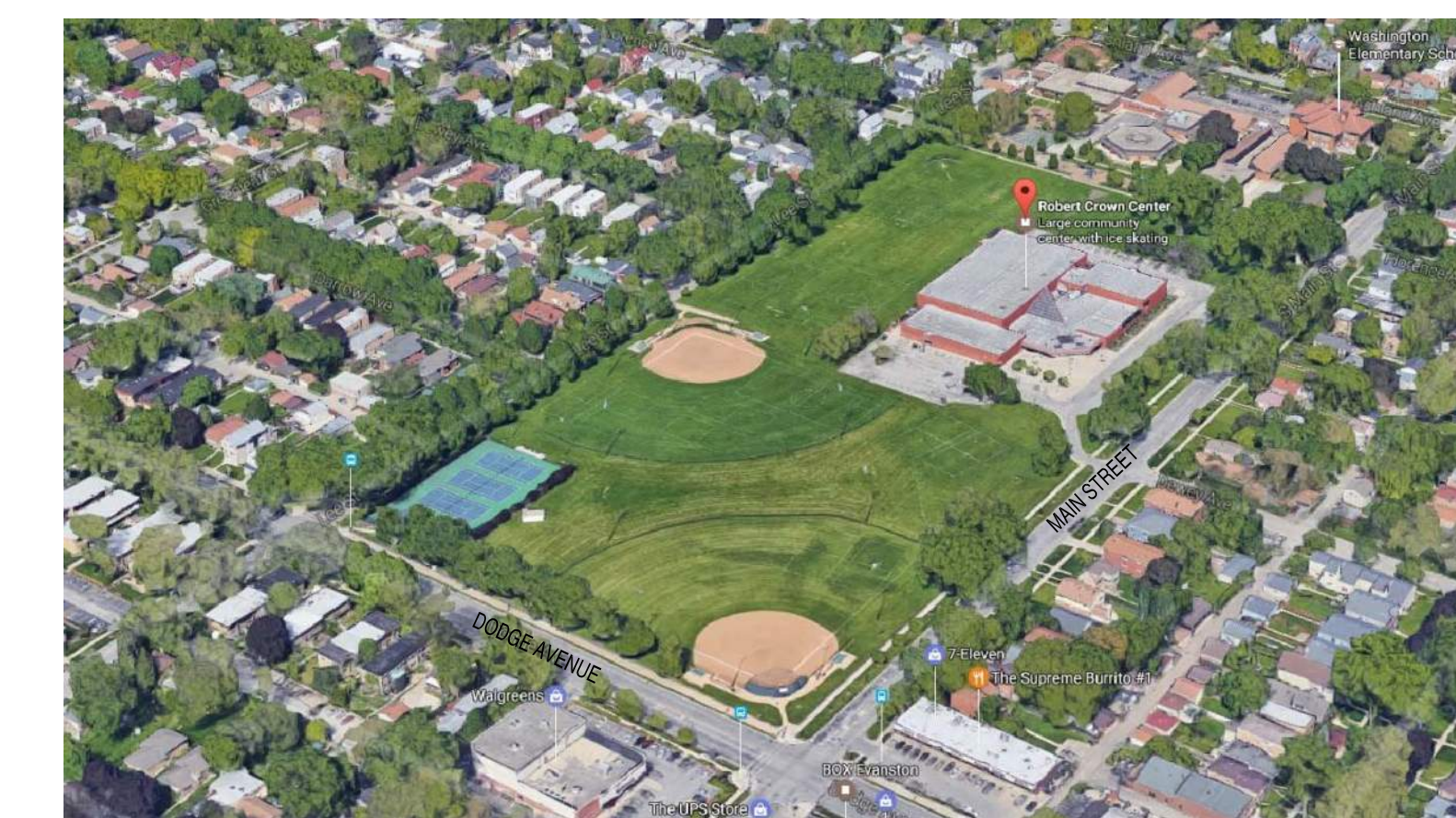

**project team**

**owner:**  
City of Evanston  
2100 Ridge Avenue  
Evanston, Illinois 60201  
847.448.4311

**structural:**  
Steam-Jogular Ltd  
223 W Jackson Blvd #1110  
Chicago, Illinois 60606  
312.461.1900

**MEP/FP:**  
Smith + Andersen  
500-4211 Yonge Street  
Toronto, Ontario M2P 2A9  
416.487.8151

**civil:**  
Terra Engineering, Ltd  
225 W Ohio Street  
Chicago, Illinois 60654  
312.467.0123

**landscape:**  
Conservation Design Forum  
403 West St. Charles Road  
Lombard, Illinois 60148  
630.559.2000

**sportsfield:**  
Jeffrey L Bruce & Company  
1907 Swift Street, Suite 204  
North Kansas City, Missouri 64116  
816.842.8999

### abbreviations

ABV	above	DBL	double	HB	hose bib	NIC	not in contract	SC	solid core
ACT	acoustical tile	DEG	degree	HC	hollow core	NO	number	SCHED	schedule
ADD	addendum	DEPT	department	HW	hardware	NOM	nominal	SD	storm drain
ADJ	adjacent	DF	drinking fountain	HDR	header	NTS	not to scale	SF	square feet
AESS	architecturally exposed structural steel	DIA	diameter	HDM	hollow metal	OC	on center	SHT	sheet
ATF	above finish floor	DISP	dispenser	HORIZ	horizontal	OD	outside diameter	SM	similar
ALUM	aluminum	DM	dimension	HR	hour	OFF	office	SMT	seamant
ALT	alternate	DIV	division	HT	height	OH	overhead	SQ	square
ANOD	anodized	DTL	detail	DN	down	OPG	opening	SST	stainless steel
AP	access panel	DR	door	DS	downspout	OPP	opposite hand	STD	standard
ARCH	architect	DT	drain tile	ID	inside diameter	INCL	include	STL	steel
AUTO	automatic	DWG	drawing	INFO	information	INSUL	insulation	STOR	storage
AVG	average	DWR	drawer	INT	interior	PERF	perforate(d)	SUSP	suspended
B/	bottom of board	EA	each	PL	plate	PKG	parking	SYM	symmetrical
BD	between	ELEV	elevation	PLAM	plaster	PL	plastic laminate	SYG	system
BETW	between	ELEC	electric(a)	PLAS	plaster	PLWB	plywood	T	tread
BIT	bituminous	EMER	emergency	PLBG	plumbing	PNT	panel	T/B	top of bottom
BLDG	building	ENG	engineer	PLYWD	plywood	PROP	property line	TEL	telephone
BLKG	blocking	EQ	equal	PNT	point	PSI	pounds per square inch	TEMP	temperature
BN	bull nose	EXIST	existing	LAM	laminat(e)	LCC	lead coated copper	T&G	tongue and groove
BRG (PL)	bearing (plate)	EXPJ	expansion joint	LAV	lavatory	LH	left hand	THK	thickness
BRZ	brance	EXP	exposed	LBL	label	LP	low point	TV	television
BSMT	basement	EXT	exterior	LH	left hand	PVC	polyvinyl chloride	TYP	typical
BTM	bottom	FB	face brick	FD	floor drain	PWT	pavement	UL	Underwriters' Laboratory
BTU(h)	british thermal unit (per hour)	FDC	fire department connection	FE(C)	fire extinguisher (cabinet)	MAN	manual	UNF	unfinished
CAB	cabinet	FE	finish floor elevation	MAX	maximum	MECH	mechanical	UNO	unless noted otherwise
CB	catch basin	FIN	finish(ed)	MEZZ	mezzanine	R	riser	VB	vapor barrier
CLG	ceiling	FLR	flooring	MFR	manufacturer	RA	return air	VCT	vinyl composition tile
CLR	clear(ance)	FND	foundation	MH	manhole	RD	roof drain	VERT	vertical
CJ	control joint	FRP	fiberglass reinforced panel	MISC	miscellaneous	REFR	refrigerator	VF	verify in field
CMU	concrete masonry unit	FT	feet	MNT	mount(ed)	REIN	reinforced, reinforcing	W/	with
CNTR	center	FTC	footing	MO	masonry opening	RET	return	WC	water closet
COL	column	GA	gauge	MOD	module, module	REV	revision(s), revised	WD	wood
CONC	concrete	GALV	galvanized	MTL	metal	RH	right hand	WIN	window
CONSTR	construction	GC	general contractor	MUL	mullion	RM	room	W/O	without
CNT	continuous	GL	glass, glazing	GYP	gypsum board	RO	rough opening	WP	waterproofing
CPR	copper							WF	welded wire fabric
CPT	corner(plate)								
CSMT	casement								
CT	ceramic tile								
CTR	counter								

### material symbols

	PLYWOOD
	BLANKET OR LOOSE FILL INSULATION
	BOARD OR FOAM PLASTIC INSULATION
	CRUSHED STONE
	SEALANT AND BACKER ROD
	GLASS
	GLASS-ELEVATION
	GYP(SUM) (WALL)BOARD OR PANEL
	PLASTER OR WALLBOARD ELEVATION
	PLASTIC-LAMINATE
	SAND
	MASONRY
	CONCRETE
	WOOD-DIMENSION LUMBER
	WOOD BLOCKING OR FURRING
	WOOD-FINISHED LUMBER
	DIMENSIONED OR VENEER STONE
	STEEL

### symbols legend

BUILDING ELEVATION	
SECTION	
DETAIL MARK	
ELEVATION MARK	
DOOR NUMBER	
ROOM DESCRIPTION	
CEILING ELEVATION	
PARTITION TYPE	
KEYED NOTE	
CASEWORK TAG	
REVISION NUMBER	

### code study

**APPLICABLE CODES:**  
CITY OF EVANSTON MUNICIPAL CODE  
2012 INTERNATIONAL BUILDING CODE (IBC)  
2012 NFPA LIFE SAFETY CODE 101  
2012 INTERNATIONAL MECHANICAL CODE  
2014 ILLINOIS STATE PLUMBING CODE  
2011 NATIONAL ELECTRIC CODE  
2012 INTERNATIONAL FIRE CODE  
2012 INTERNATIONAL ENERGY CONSERVATION CODE  
2010 AMERICANS WITH DISABILITIES ACT  
STATE OF ILLINOIS ACCESSIBILITY CODE  
ILLINOIS ENERGY CONSERVATION CODE

### int'l building code 2012

**SECTION 300 USE AND OCCUPANCY CLASSIFICATION**  
2012 CLASSIFICATION  
ICE RINKS - ASSEMBLY, GROUP A-4  
CHRYSLERUM - ASSEMBLY, GROUP A-3  
LIBRARY - ASSEMBLY, GROUP A-3  
PRESCHOOL - EDUCATION, GROUP E  
ADMINISTRATION - BUSINESS, GROUP B

### SECTION 500 GENERAL HEIGHT AND AREA LIMITATIONS

ALLOWABLE: 11 STORY UNLIMITED SF  
ACTUAL: 2 STORY, 90,000 SF (MAX)

### SECTION 600 TYPES OF CONSTRUCTION

602.1 CONSTRUCTION CLASSIFICATIONS:  
TYPE 1-B CONSTRUCTION, FULLY SPRINKLERED

### SECTION 1000 MEANS OF EGRESS

SEE EXITING INFORMATION IN CHART BELOW THIS SHEET.

### project data

**PROJECT NAME:**  
ROBERT CROWN COMMUNITY CENTER ICE COMPLEX AND LIBRARY

**PROJECT OWNER:**  
CITY OF EVANSTON

**PROJECT DESCRIPTION:**  
NEW 2-STORY, 130,000 SF COMMUNITY CENTER, EXTERIOR PARKING LOT, SPORTS FIELDS, AND SITE IMPROVEMENTS PER PLANS

**Woodhouse Tinucci Architects**  
230 W Superior 8th Flr Chicago IL 60654  
Tel 312 943 3120 www.woodtinarch.com

**MJMA**  
mclennan jaukskas miller architects  
425 adelade street west level 6  
toronto ontario m5c 3c1  
416 593 6796  
www.mjma.ca

### accessibility

THIS PROJECT WILL COMPLY FULLY WITH THE FOLLOWING:  
ILLINOIS ACCESSIBILITY CODE  
ANSI A117.1-2003  
2010 ADA

### ILLINOIS ACCESSIBILITY CODE:

**SECTION 400.310: NEW CONSTRUCTION**  
ALL FACILITIES WILL FULLY COMPLY WITH REQUIREMENTS FOR NEW CONSTRUCTION.

### SECTION 400.310(a): ACCESSIBLE ROUTE.

400.310(a)2 WIDTH: MINIMUM CLEAR WIDTH SHALL BE 36 IN.

### SECTION 400.310(f): CONTROLS AND OPERATING MECHANISMS

ALL CONTROL AND OPERATING MECHANISMS WILL COMPLY WITH ACCESSIBILITY REQUIREMENTS.

### SECTION 400.310(g): SIGNAGE

ANY NEW SIGNAGE WILL COMPLY WITH ACCESSIBILITY REQUIREMENTS AND WILL BE PROVIDED UNDER SEPARATE CONTRACT

© copyright 2017  
**Robert Crown  
Community Center**

1701 S. Main Street,  
Evanston, IL 60202

site plan  
**G1.0**

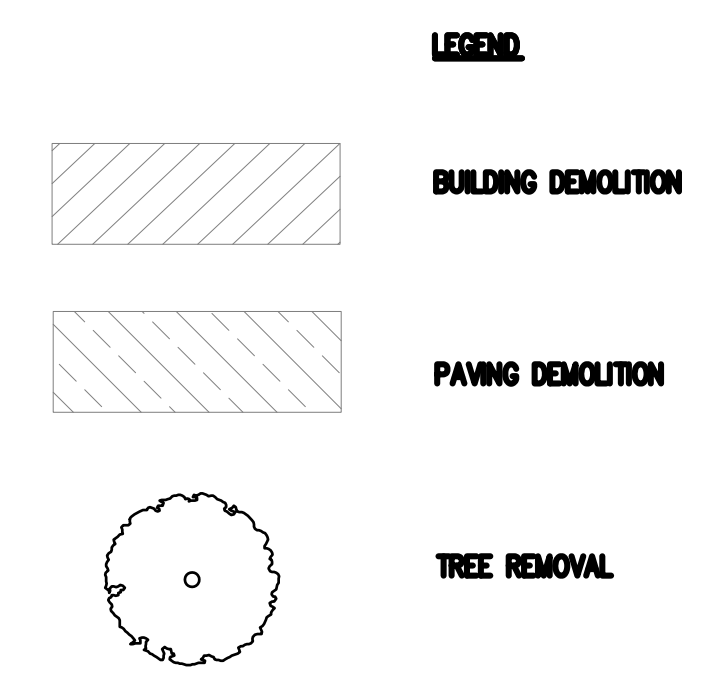
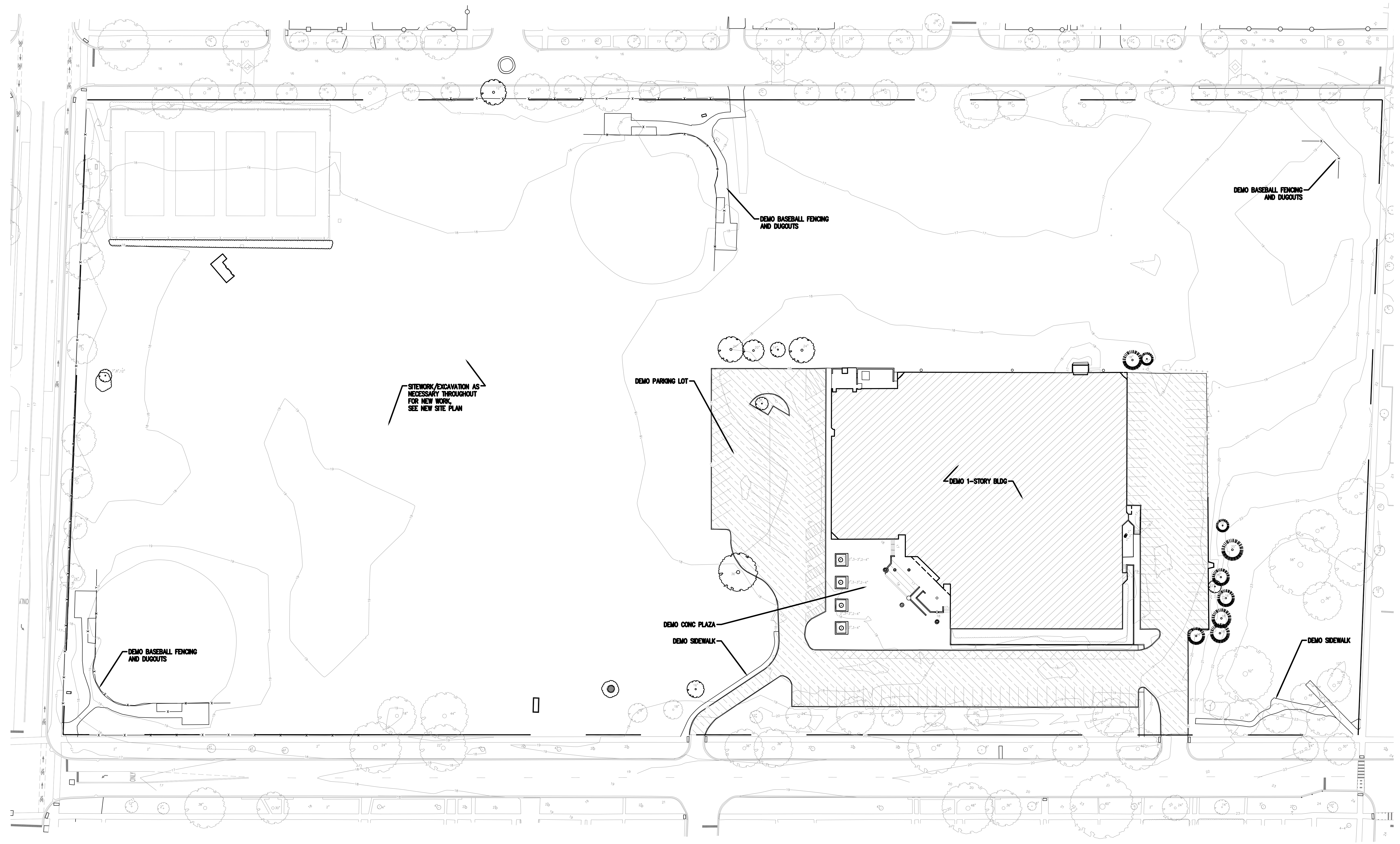

project team

owner:  
City of Evanston  
2100 Ridge Avenue  
Evanston, Illinois 60201  
847.448.4311

structural:  
Stearn-Joglekar Ltd  
223 W Jackson Blvd #1110  
Chicago, Illinois 60606  
312.461.1900

MEP/FP:  
Smith + Anderson  
500-4211 Yonge Street  
Toronto, Ontario M2P 2A9  
416.487.8151

civil:  
Terra Engineering, Ltd  
225 W Ohio Street  
Chicago, Illinois 60654  
312.467.0123

landscape:  
Conservation Design Forum  
403 West St. Charles Road  
Lombard, Illinois 60148  
630.559.2000

sportsfield:  
Jeffrey L Bruce & Company  
1907 Swift Street, Suite 204  
North Kansas City, Missouri 64116  
816.842.8999

Woodhouse Tinucci Architects  
230 W Superior 6th Flr Chicago IL 60654  
Tel 312 943 3120 www.woodtinarch.com

**MJMA**  
maclennan jaunkalns miller architects  
428 adelgade street west level 6  
toronto ontario m5p 3c1  
416 973 6776  
www.mjma.ca

© copyright 2017

**Robert Crown  
Community Center**  
1701 S. Main Street,  
Evanston, IL 60202

1 Site Plan  
L6.0 SCALE: 1"=40'

site demolition plan  
**C1.0**



LEGEND

- 4' CONCRETE CATCH BASIN
- 2' ADS PVC CATCH BASIN
- 4' CONCRETE CATCH BASIN (OUTLET CONTROL STRUCTURE)
- STORM SEWER 8" CLEANOUT
- 21.00 x SPOT ELEVATION
- STORM SEWER HDPE PIPE, SOLID
- PP STORM SEWER HDPE PIPE, PERFORATED
- ▨ SOIL CELL AREA
- ▨ GRAVEL STORAGE AREA - SUBGRADE ELEVATION WITHIN HATCHED GRAVEL STORAGE = 14.00

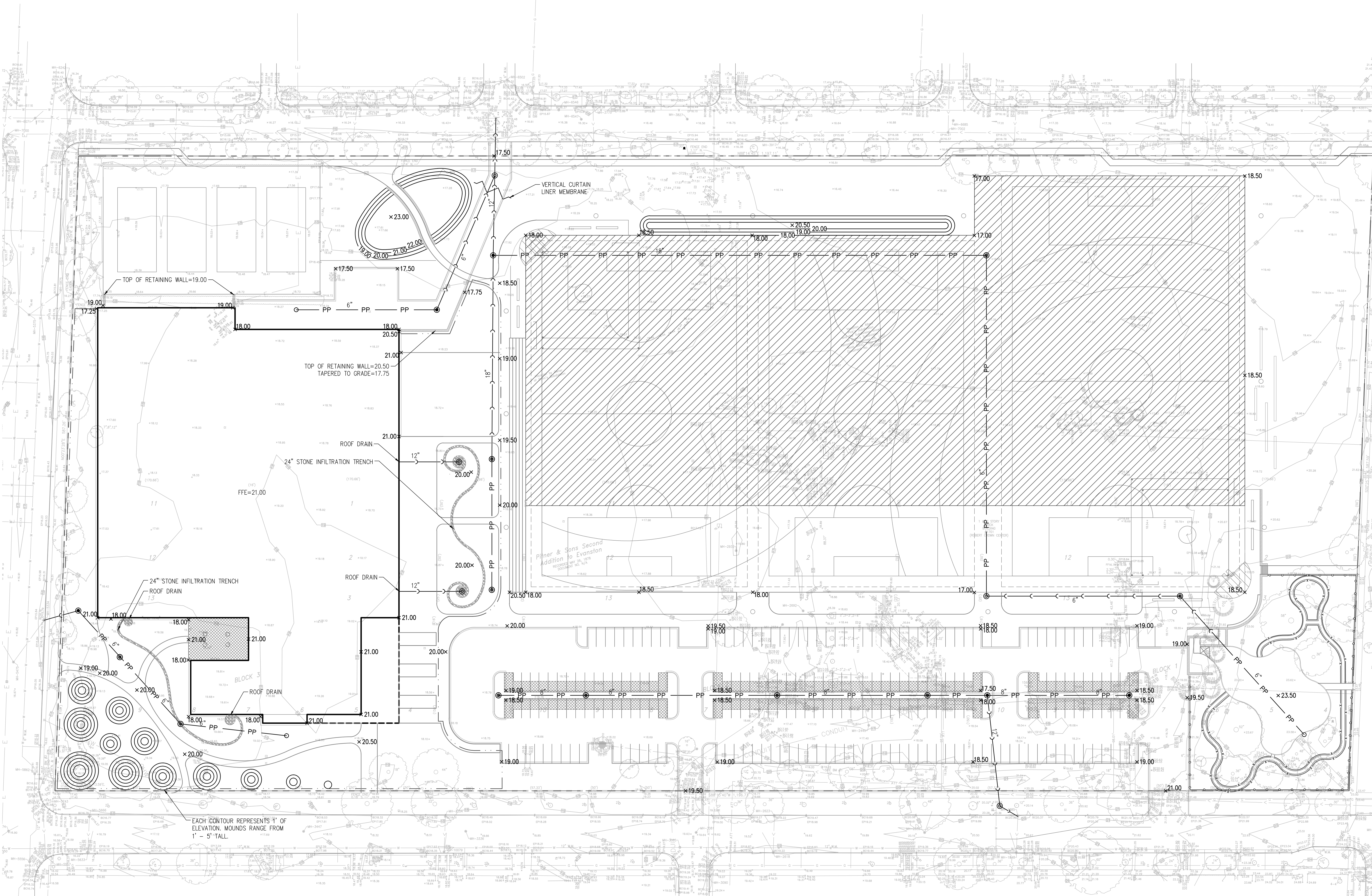

project team

owner:  
City of Evanston  
2100 Ridge Avenue  
Evanston, Illinois 60201  
847.448.4311

structural:  
Stearn-Joglekar Ltd  
223 W Jackson Blvd #1110  
Chicago, Illinois 60606  
312.461.1800

MEP/FP:  
Smith + Andersen  
500-4211 Yonge Street  
Toronto, Ontario M2P 2A9  
416.487.8151

civil:  
Terra Engineering, Ltd  
225 W Ohio Street  
Chicago, Illinois 60654  
312.467.0123

landscape:  
Conservation Design Forum  
403 West St. Charles Road  
Lombard, Illinois 60148  
630.559.2000

sportsfield:  
Jeffrey L Bruce & Company  
1907 Swift Street, Suite 204  
North Kansas City, Missouri 64116  
816.842.8999

Woodhouse Tinucci Architects  
230 W Superior 6th Flr Chicago IL 60654  
Tel 312 943 3120 www.woodtinarch.com

**MJMA**  
maclean jaunkals miller architects  
425 adelade street west level 6  
toronto ontario m5h 3c1  
416 593 6796  
www.mjma.ca

© copyright 2017

**Robert Crown  
Community Center**

1701 S. Main Street,  
Evanston, IL 60202

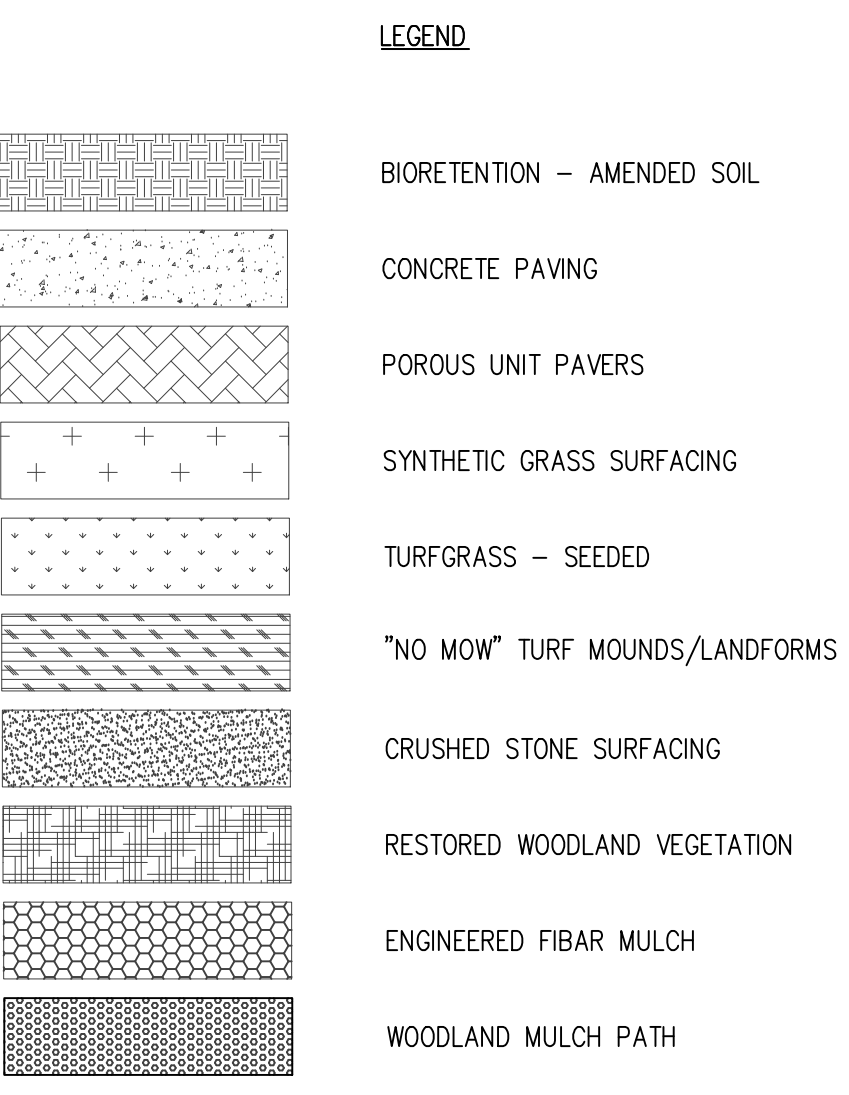
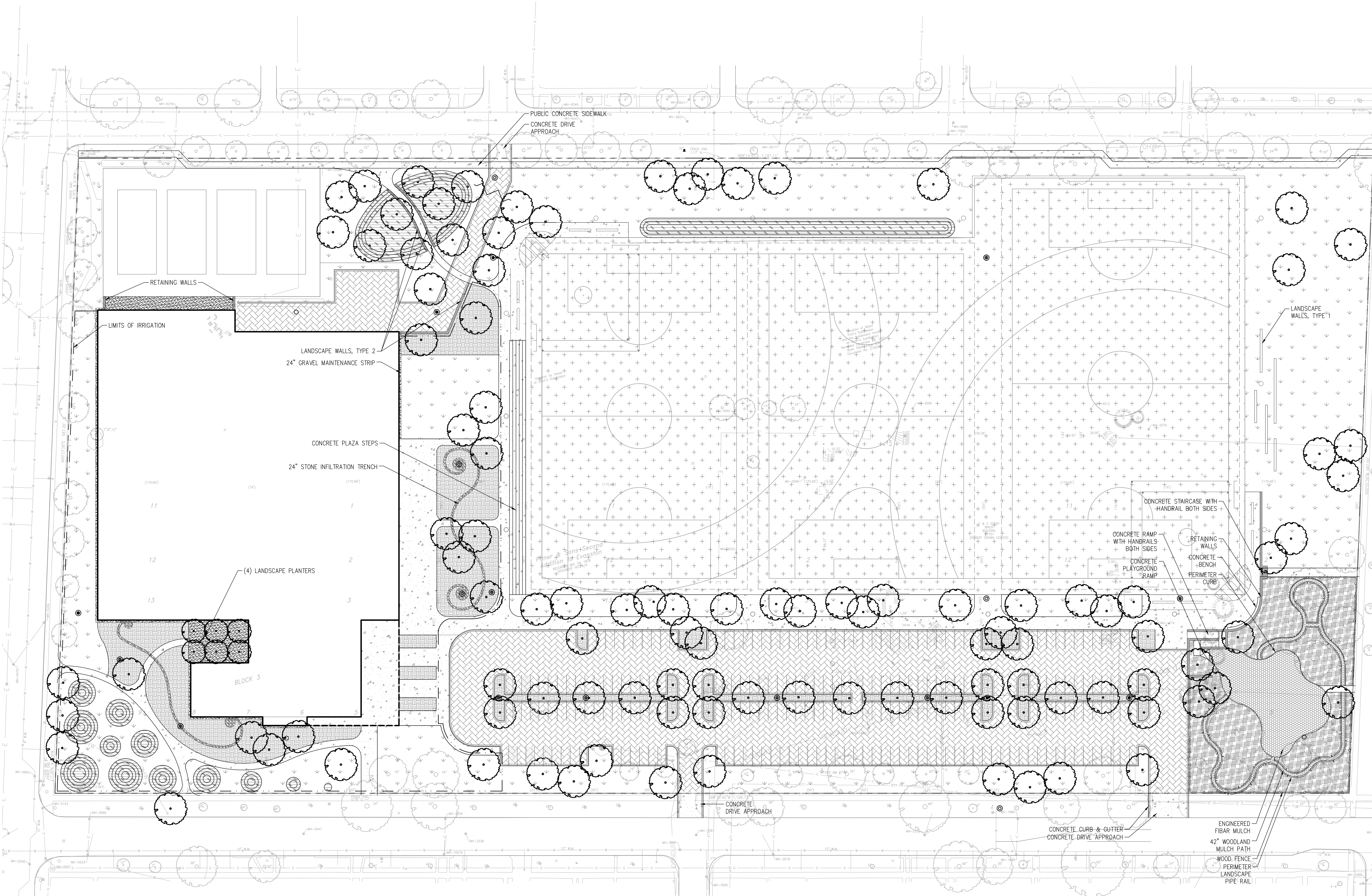

project team owner: City of Evanston, 2100 Ridge Avenue, Evanston, Illinois 60201, 847.448.4311. structural: Stearn-Joglekar Ltd, 223 W Jackson Blvd #1110, Chicago, Illinois 60606, 312.461.1800. MEP/FP: Smith + Andersen, 500-4211 Yonge Street, Toronto, Ontario M2P 2A9, 416.487.8151. civil: Terra Engineering, Ltd, 225 W Ohio Street, Chicago, Illinois 60654, 312.467.0123. landscape: Conservation Design Forum, 403 West St. Charles Road, Lombard, Illinois 60148, 630.559.2000. sportsfield: Jeffrey L Bruce & Company, 1907 Swift Street, Suite 204, North Kansas City, Missouri 64116, 816.842.8999.

Woodhouse Tinucci Architects, 230 W Superior 6th Flr Chicago IL 60654, Tel 312 943 3120 www.woodtinorchi.com

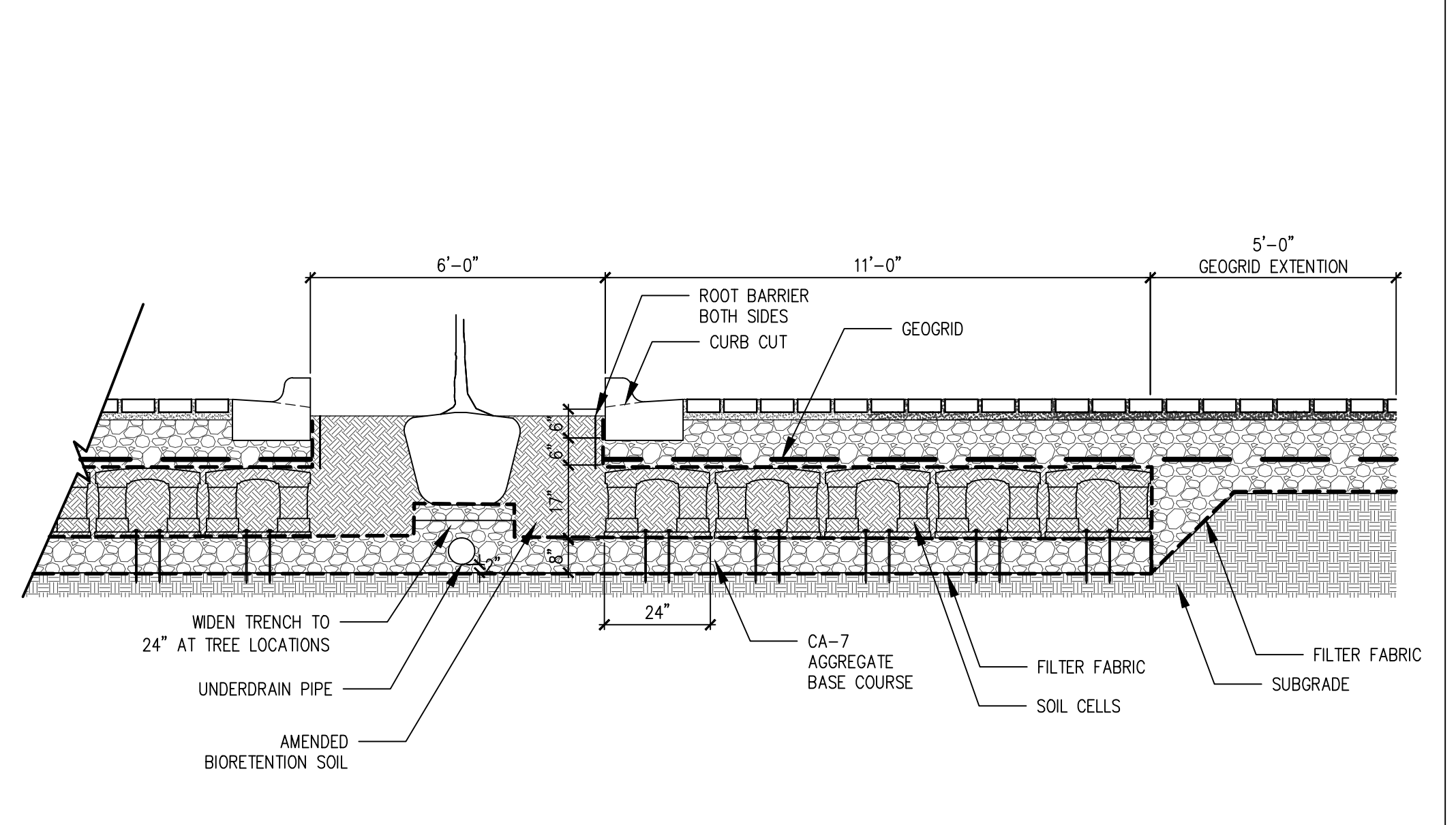
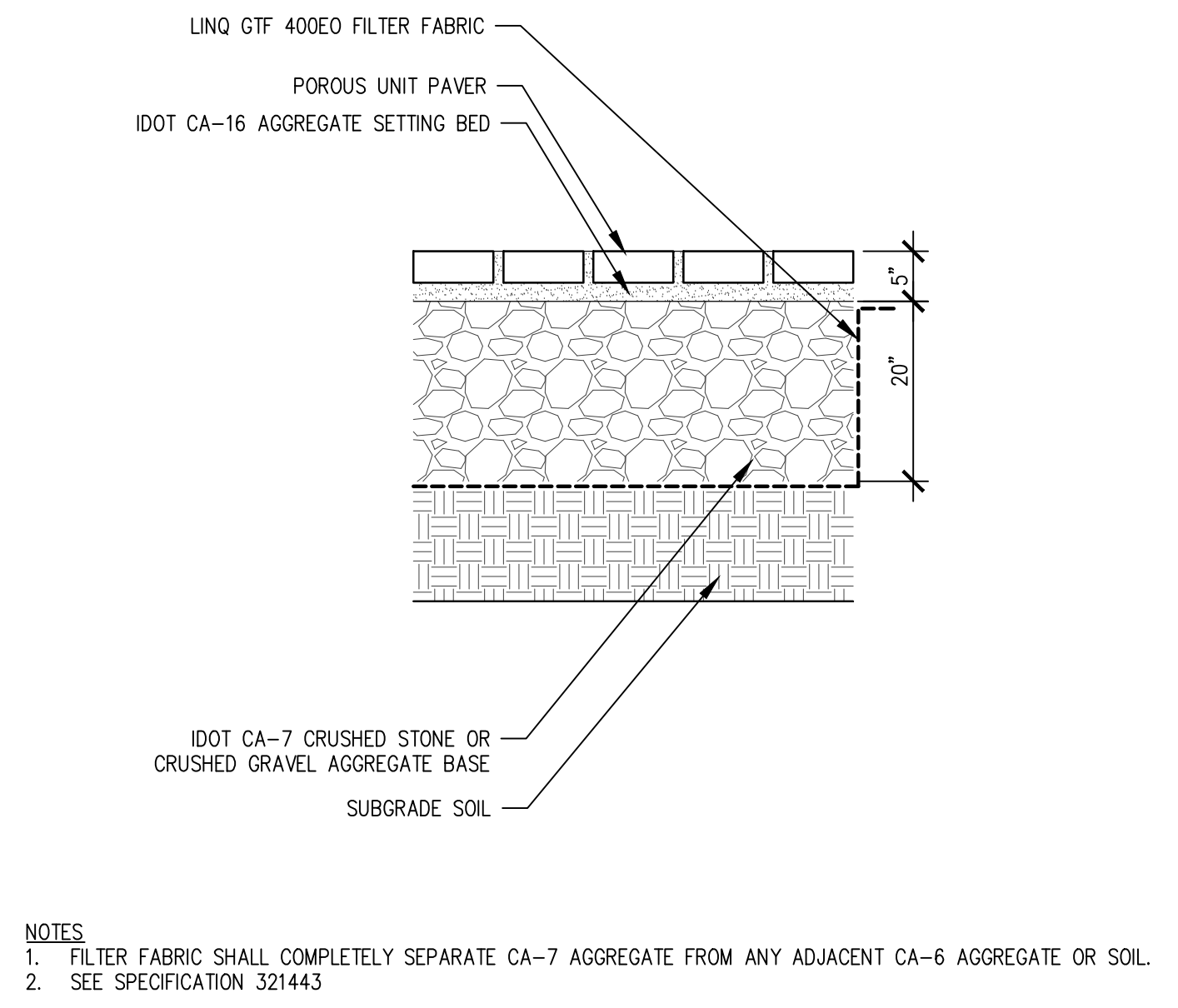
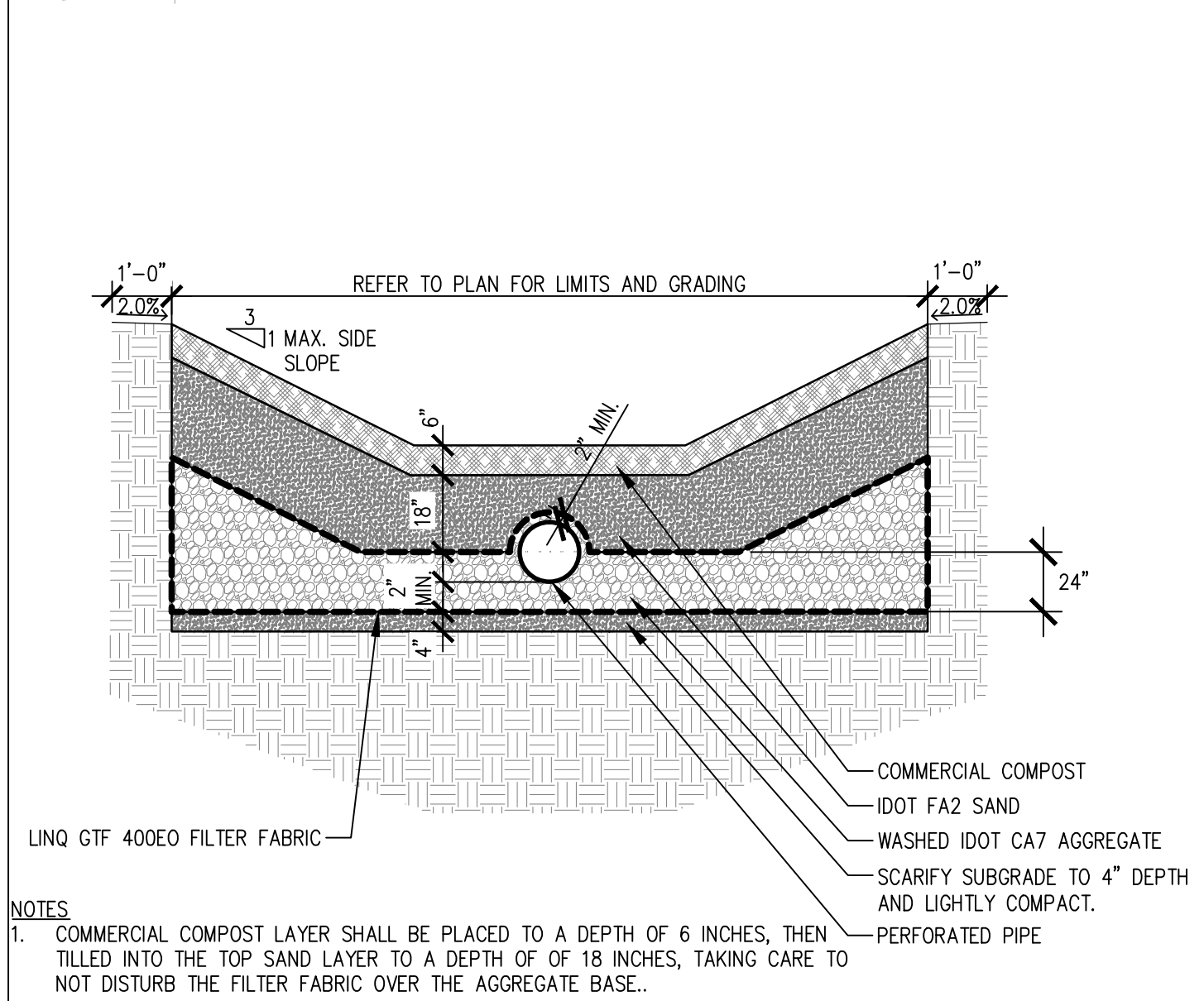

**C** BIORETENTION AREA 3/8"=1'-0" bioretention - type 1.dwg © 2011 by Conservation Design Forum, Inc

**B** POROUS UNIT PAVERS 3/4"=1'-0" L06.00 Site Plan © 2013 by Conservation Design Forum, Inc

**A** SOIL CELL 3/8"=1'-0" File Name © 2009 by Conservation Design Forum, Inc

1 Site Plan 1/8" SCALE: 1"=40'

© copyright 2017 Robert Crown Community Center 1701 S. Main Street, Evanston, IL 60202

site plan L6.0

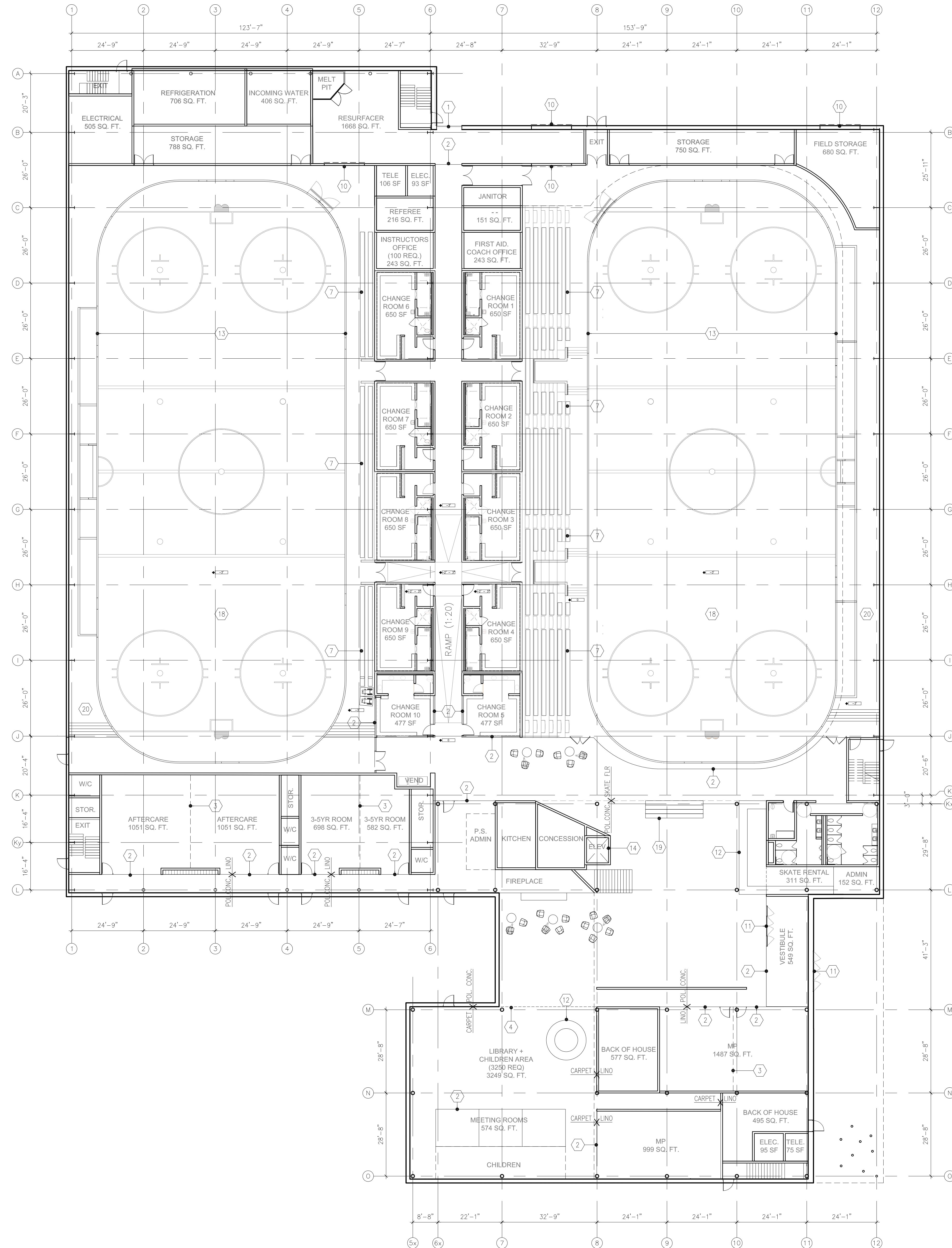

1 Issued for Schematic Design 08.11.17  
notes

- 1 curtain wall system 1
- 2 all glass partition
- 3 operable partition
- 4 operable glass partition (12' high)
- 5 glass guard
- 6 phenolic guard
- 7 fixed bench seating
- 8 telescoping seating
- 9 drop-down divider curtain
- 10 overhead ceiling door
- 11 automatic sliding door
- 12 reception desk
- 13 arena board system
- 14 elevator
- 15 wood athletic floor
- 16 resilient athletic flooring
- 17 resilient athletic floor, fluid applied
- 18 ice-link slab
- 19 warm-side viewing
- 20 sealed concrete floor

keyed notes

project team

owner:  
City of Evanston  
2100 Ridge Avenue  
Evanston, Illinois 60201  
847.448.4311

structural:  
Steam-Joglar Ltd  
223 W Jackson Blvd #1110  
Chicago, Illinois 60606  
312.461.1600

MEP/FP:  
Smith + Andersen  
500-4211 Yonge Street  
Toronto, Ontario M2P 2A9  
416.487.8151

civil:  
Terra Engineering, Ltd  
225 W Ohio Street  
Chicago, Illinois 60654  
312.467.0123

landscape:  
Conservation Design Forum  
403 West St. Charles Road  
Lombard, Illinois 60148  
630.559.2000

sportsfield:  
Jeffrey L Bruce & Company  
1907 Swth Street, Suite 204  
North Kansas City, Missouri 64116  
816.842.8999

**Woodhouse Tinucci Architects**  
230 W Superior 8th Flr Chicago IL 60654  
Tel 312 943 3120 www.woodtinarch.com

**MJMA**  
MacLennan Jaunkalns Miller Architects  
425 Adelaide Street West, Level 6  
Toronto, ON M5V 3C1, Canada  
416.593.6796  
www.mjmachitects.com

© copyright 2017

**Robert Crown  
Community Center**

1701 S. Main Street,  
Evanston, IL 60202